

SUPER CRANES

fischertechnik 

ADVANCED



Inhalt
Contents
Contenu

Inhoud
Contenido
Conteúdo

Einzelteilübersicht / Spare parts list / Liste des pièces détachées / Onderdelenoverzicht / Lista da peças / Resumo de peça individual S. / p. 2

Montagetipps / Tips for assembly / Tuyaux pour le montage / Montagetips / Consejos para el montaje / "Dicas" para montagem S. / p. 3

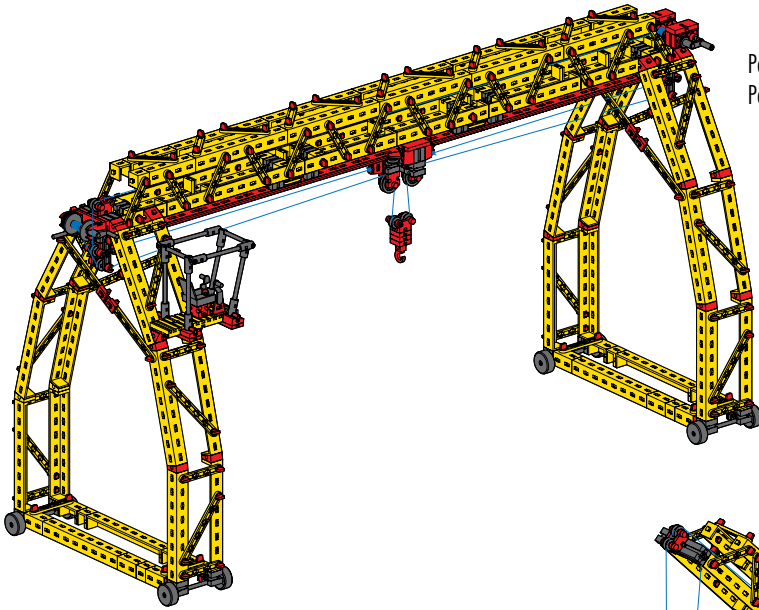

Portalkran / Gantry crane / Grue à portique /
Portaalkraan / Grúa de pórtico / Guindaste de pórtico S. / p. 5



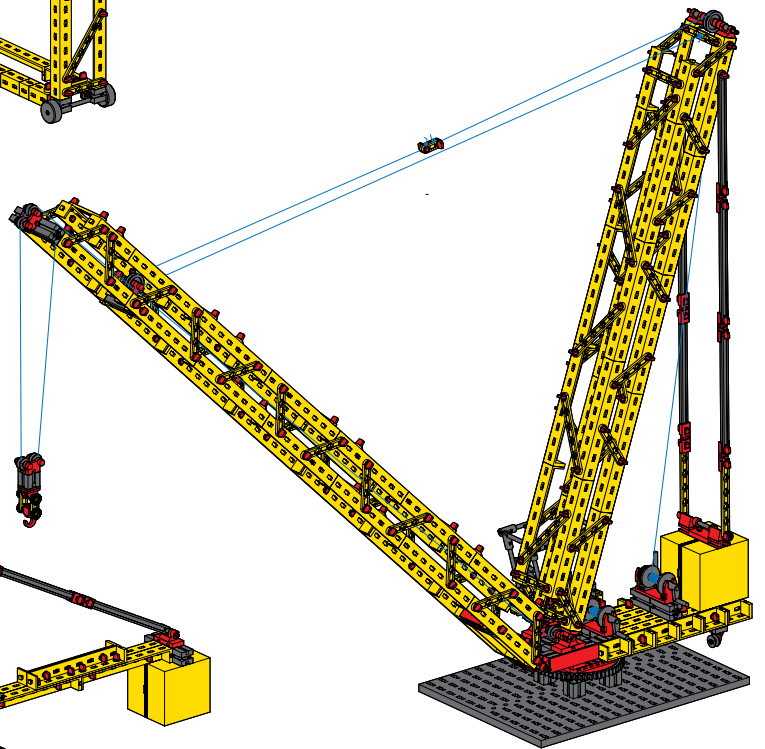









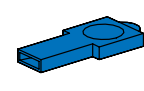

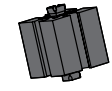

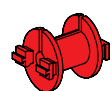

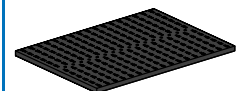

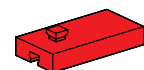

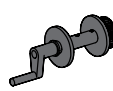
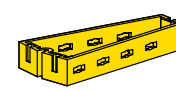



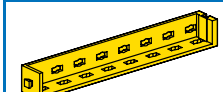
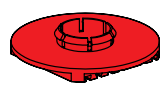

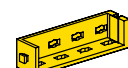

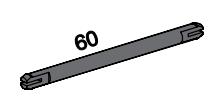

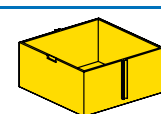
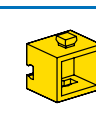

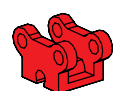
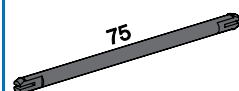

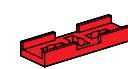
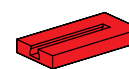



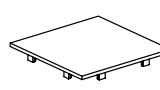

Schwerlastkran / Heavy-duty crane /
Grue pour charges lourdes / Kraan voor zware lasten /
Grúa para cargas pesadas / Guindaste titan S. / p. 17

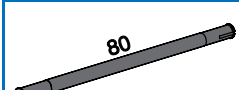

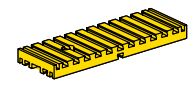
Baustellenkran / Building site crane / Grue de chantier /
Bouwkraan / Grúa para obras / Guindaste giratório S. / p. 31

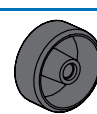
Einzelteilübersicht
Spare parts list
Liste des pièces détachées

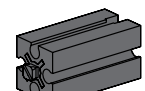
Onderdelenoverzicht
Lista da piezas
Resumo de peça individual

 60°	31 010 10 x	 15°	31 981 18 x		32 881 22 x		35 799 1 x
 30°	31 011 4 x		31 982 26 x		32 882 8 x		35 806 1 x
	31 016 2 x		31 994 2 x		32 985 1 x		
 15	31 060 8 x		31 997 2 x		35 049 3 x		35 945 2 x
 30	31 061 2 x		31 998 2 x		35 052 2 x		36 227 12 x
	31 390 1 x		31 999 2 x		35 053 4 x		36 294 47 x
	31 391 1 x		32 064 4 x	 120	35 060 14 x		36 297 8 x
	31 426 6 x	 7,5°	32 071 4 x	 60	35 065 9 x		36 298 8 x
	31 436 8 x		32 076 2 x		35 076 12 x		36 299 11 x
	31 597 3 x		32 085 5 x	 75	35 087 3 x	 4	36 323 220 x
	31 667 20 x		32 330 6 x		35 088 1 x	 6	36 324 18 x
	31 690 8 x		32 846 1 x		35 360 2 x		36 333 3 x
	31 766 1 x		32 850 3 x	 80	35 405 4 x		36 334 4 x
	31 771 1 x		32 861 1 x		35 668 4 x		36 574 8 x
	31 772 1 x		32 879 15 x		35 797 2 x		36 819 4 x

Einzelteilübersicht
Spare parts list
Liste des pièces détachées

	36 912 4 x		37 468 2 x
	36 924 6 x		37 636 4 x
	36 952 1 x		37 679 17 x
	37 237 17 x		38 225 1 x
	37 238 6 x		38 253 4 x

Onderdelenoverzicht
Lista da piezas
Resumo de peça individual

	38 258 12 x		38 541 49 x
	38 413 6 x		38 542 11 x
	38 415 1 x		38 544 4 x
	38 428 3 x		38 545 28 x
	38 464 2 x		124 199 30 x

Montagetipps
Tips for assembly
Tuyaux pour le montage

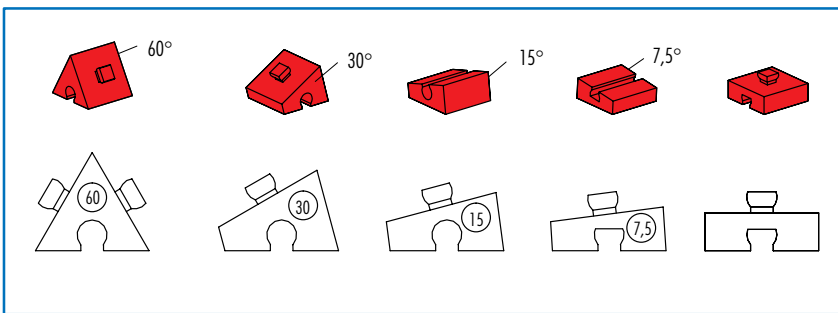

Montagetipps
Consejos para el montaje
"Dicas" para montagem

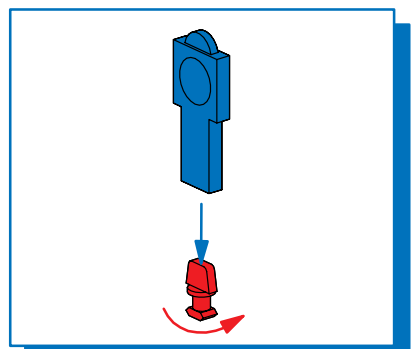
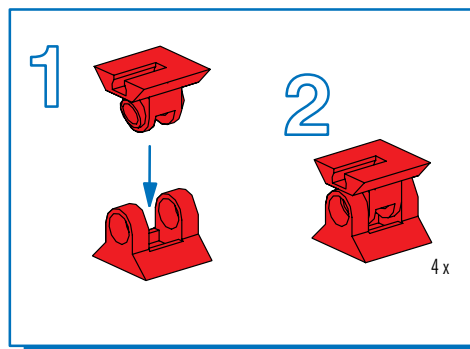
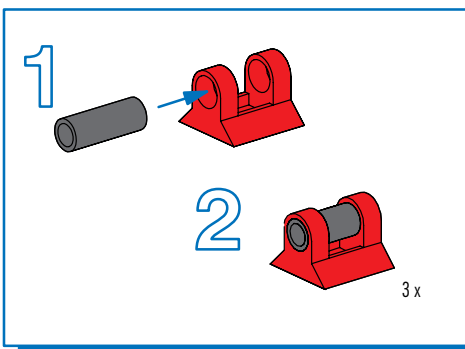
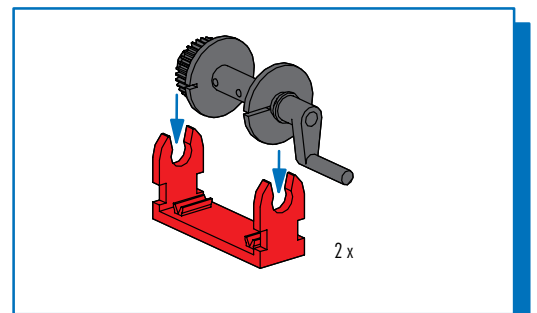

Montagetipps
Tips for assembly
Tuyaux pour le montage

Montagetipps
Consejos para el montaje
"Dicas" para montagem

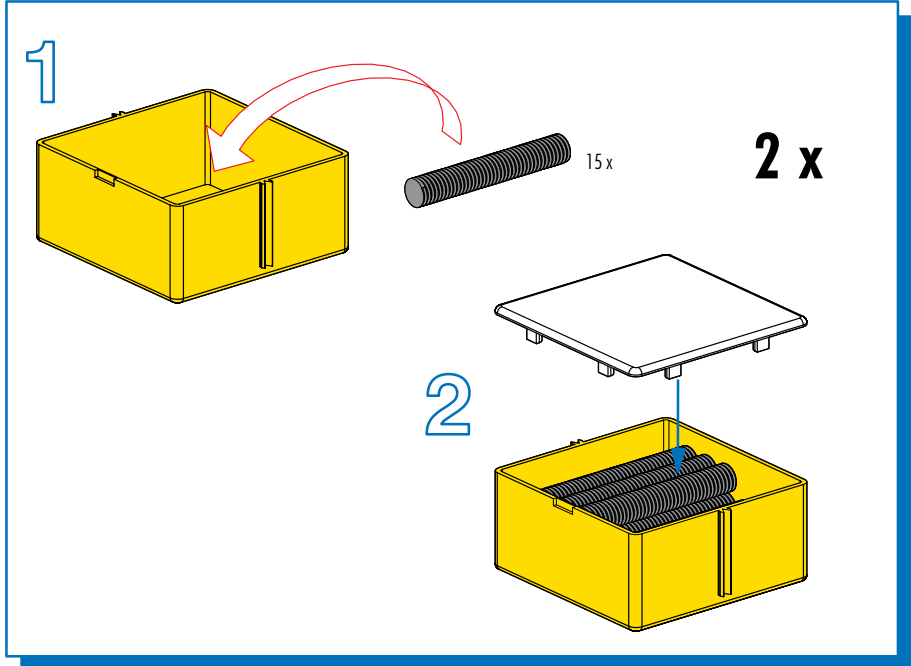
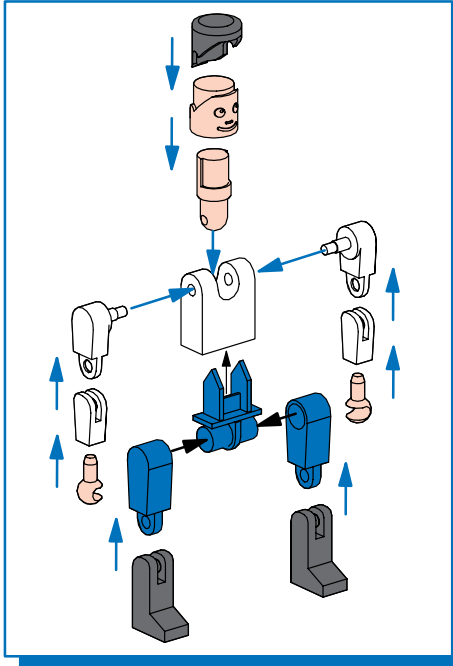

Seile **Touwen**
Cables **Cables**
Câbles **Cordas**

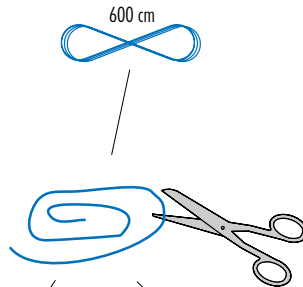

Knoten verhindert ausfransen
 Knots prevent fraying
 Le noeud empêche l'effilochage
 Knopen voorkomen het uitrafelen
 Nudos impiden el deshilachado
 Nó para evitar a desintegração da corda

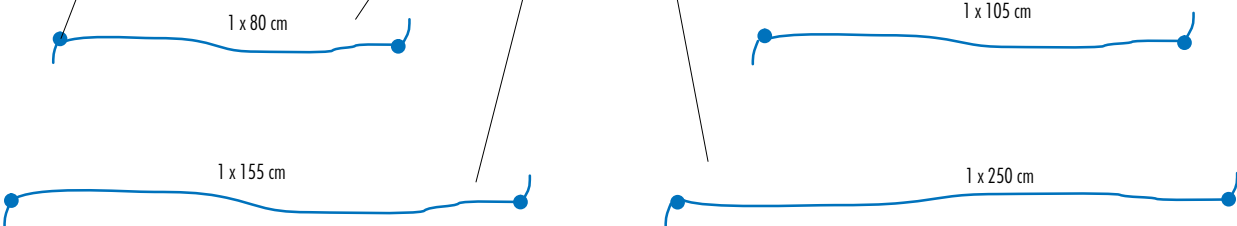

■ Alle Einzelteile, insbesondere bewegliche Teile sind falls notwendig zu warten und zu reinigen.
 ■ All components, especially moving parts, should be maintained and cleaned as necessary.
 ■ Toutes les pièces détachées et en particulier les pièces mobiles, sont, si nécessaire, à entretenir et à nettoyer.

■ Alle onderdelen, vooral de bewegende delen, kunnen, indien noodzakelijk, onderhouden en gereinigd worden.
 ■ Es necesario limpiar y mantener en buen estado todas las diferentes piezas - especialmente las piezas móviles.
 ■ Caso necessário, todas as peças individuais, especialmente peças móveis, tem que ser submetidas à manutenção e ser limpas.

■ Achtung
 Verletzungsgefahr an Bauteilen mit funktionsbedingten scharfen Kanten und Spitzen!
 ■ Caution
 Be careful not to hurt yourself on components with sharp or pointed edges!
 ■ Attention
 Risque de blessure sur les éléments comportant des arêtes et o pointes vives indispensables au bon fonctionnement!

■ Let op
 U kunt zich bezeren aan bouwstenen met scherpe randen of punten!
 ■ Attenzione
 Esiste il pericolo di lesione con i pezzi di costruzione che hanno bordi e punte spigolosi necessari per la funzionalità del pezzo!
 ■ Atenção
 Perigo de ferimentos em peças componentes com cantos vivos e pontas obrigatórios para o funcionamento !



Portalkran
Gantry crane
Grue à portique

Portaalkraan
Grúa de pórtico
Guindaste de pórtico

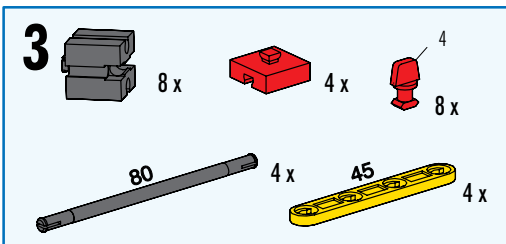
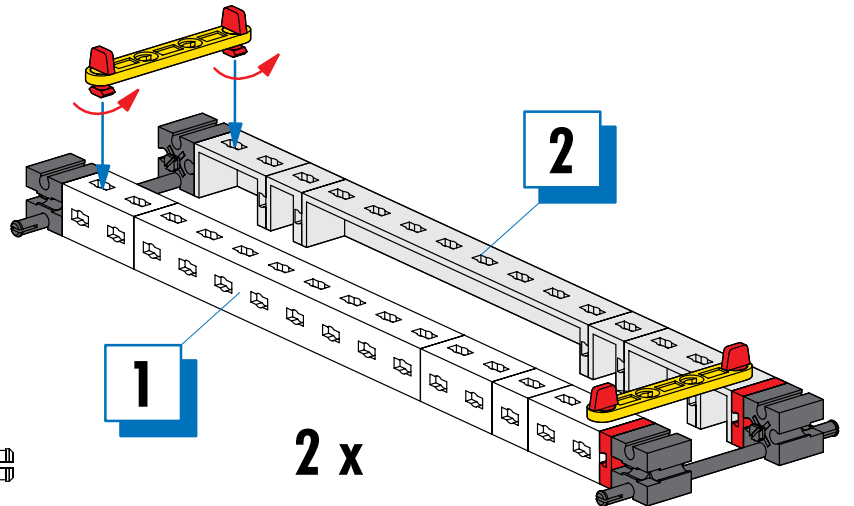
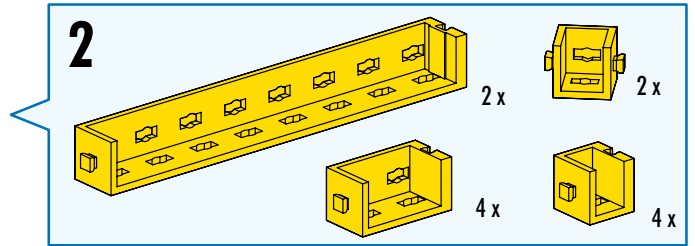
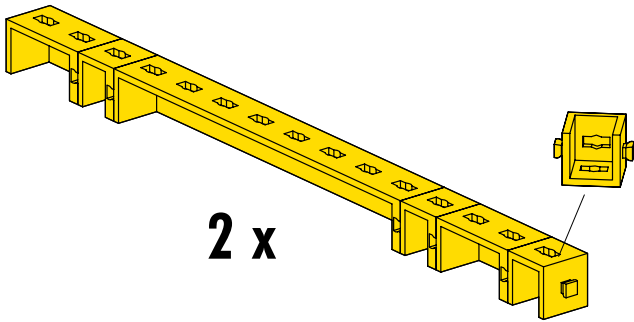
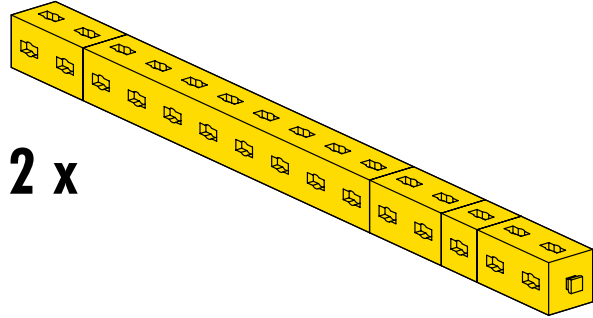
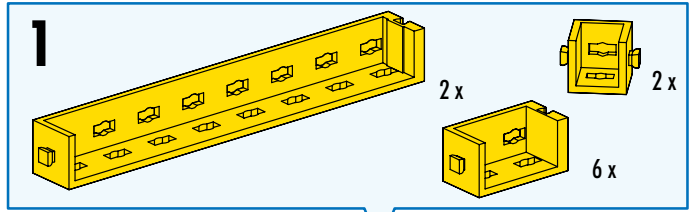
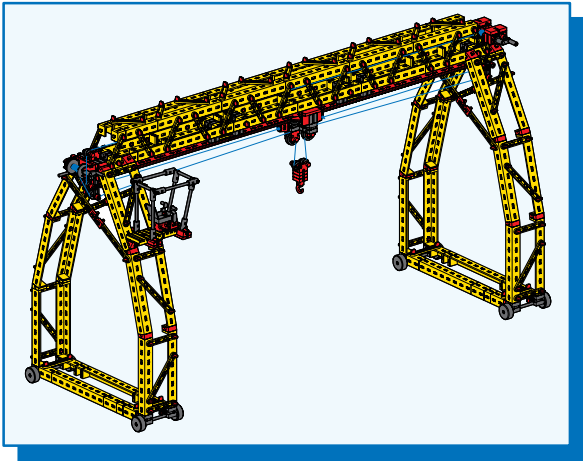

4 x

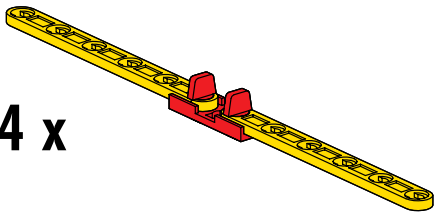

4



5

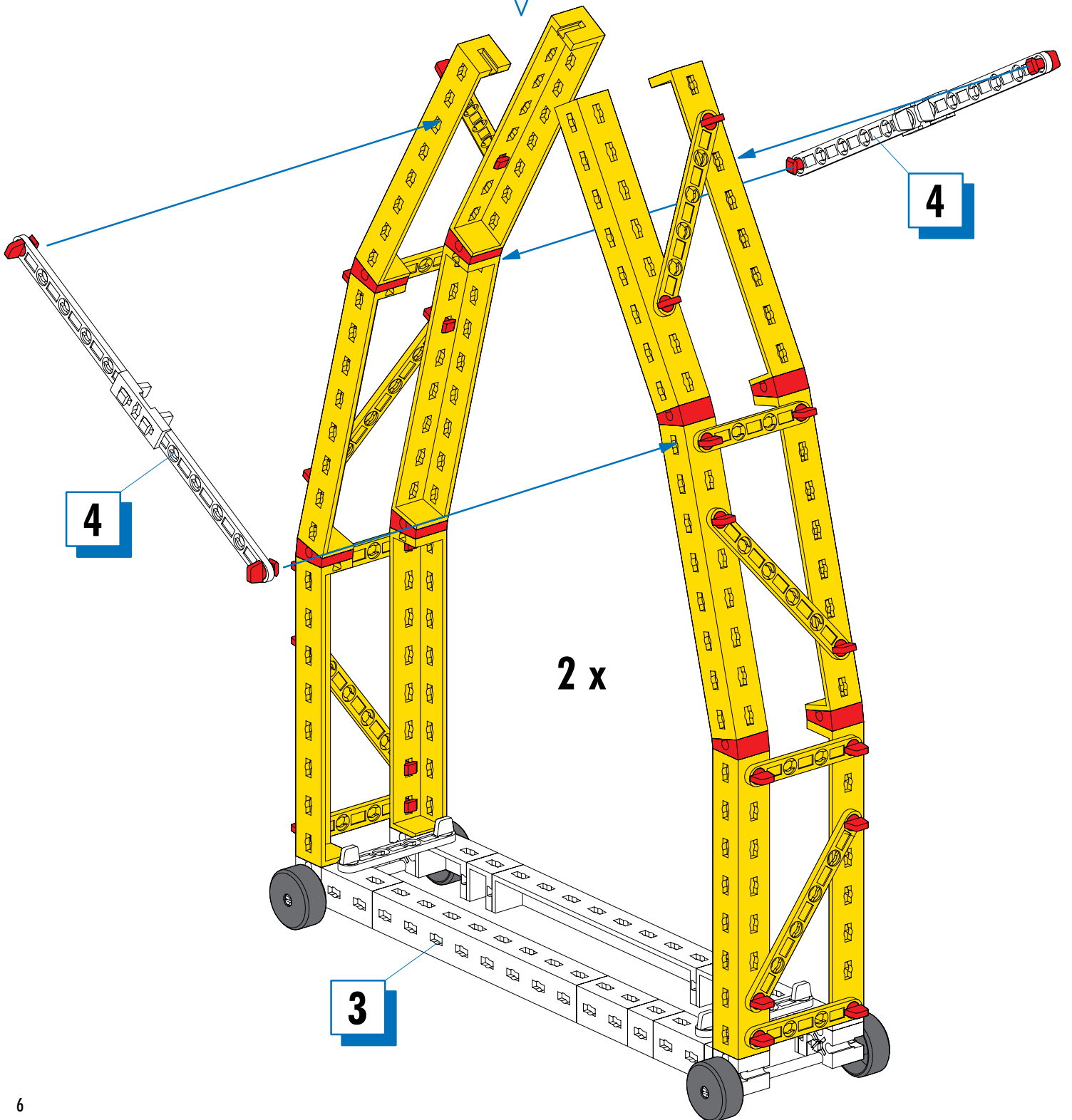
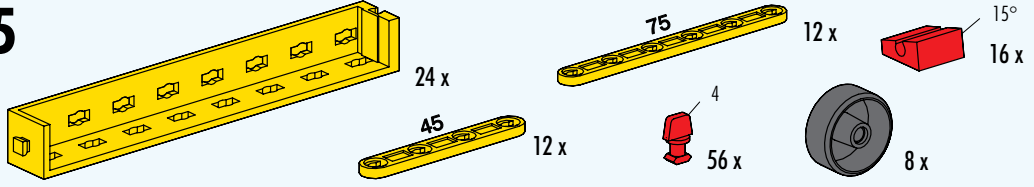

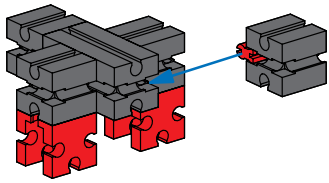

- 6**
- 1 x [Grey Technic Beam 1x3]
 - 4 x [Grey Technic Pin]
 - 2 x [Red Technic Connector]
 - 1 x [Red Technic Pin 15]

- 7**
- 2 x [Grey Technic Pin]
 - 4 x [Red Technic 30° Wedge]
 - 2 x [Red Technic Pin]
 - 2 x [Red Technic Pin]
 - 2 x [Red Technic Pin]
 - 2 x [Grey Technic Wheel]

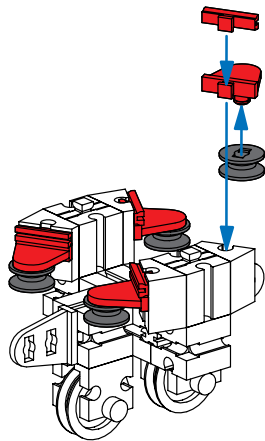
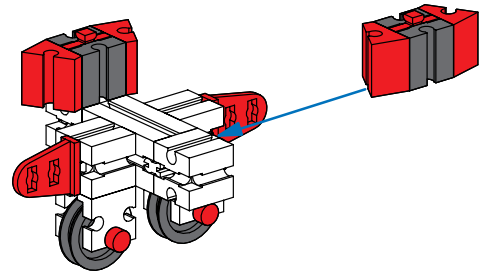

- 8**
- 4 x [Red Technic Pin]
 - 4 x [Red Technic Pin]
 - 4 x [Grey Technic Wheel]

- 9**
- 3 x [Red Technic Beam 1x15]
 - 12 x [Yellow Technic Pin]
 - 6 x [Grey Technic Pin]
 - 6 x [Grey Technic Pin]

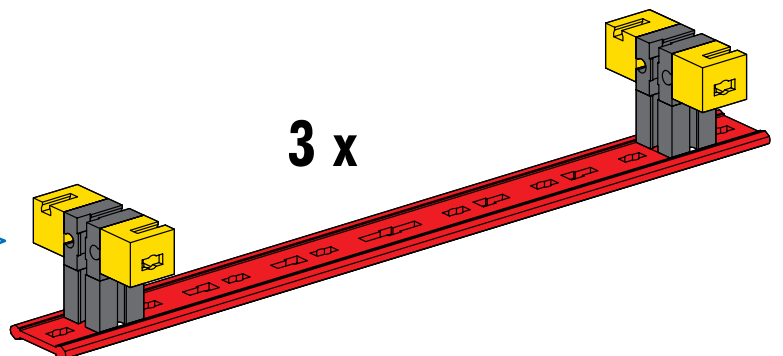

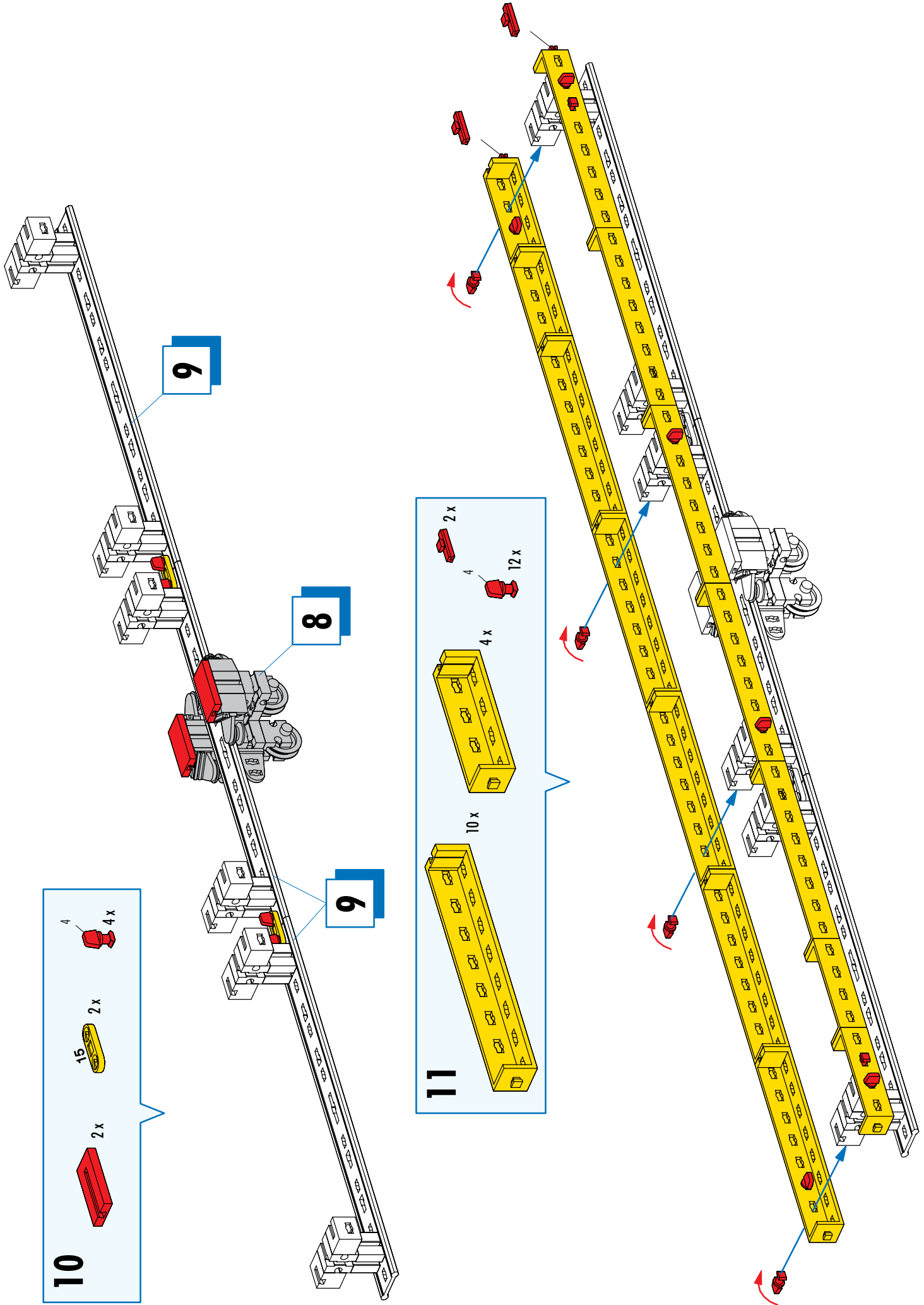

9

8

9

10

2 x

15

2 x

4

4 x

11

10 x

4 x

4

2 x

12 x

16

- 9 x [Yellow Technic beam 11-hole]
- 4 x [Yellow Technic beam 5-hole]
- 2 x [Yellow Technic beam 3-hole]
- 42-A [Yellow Technic axle]
- 11 x [Red Technic pin]
- 22 x [Red Technic pin]

15

16

17

- 4 x [Red Technic pin]
- 52 x [Red Technic pin]
- 6 x [Red Technic pin]
- 4 x [Red Technic pin]
- 45 [Yellow Technic axle]
- 28 x [Yellow Technic axle]
- 3 x [Red Technic pin]
- 60° [Red Technic pin]
- 2 x [Red Technic pin]
- 3 x [Red Technic pin]
- 1 x [Red Technic pin]
- 2 x [Red Technic pin]
- 75 [Grey Technic axle]
- 1 x [Grey Technic axle]
- 1 x [Red Technic pin]
- 1 x [Red Technic pin]

75 mm

! ≠

6 4

18

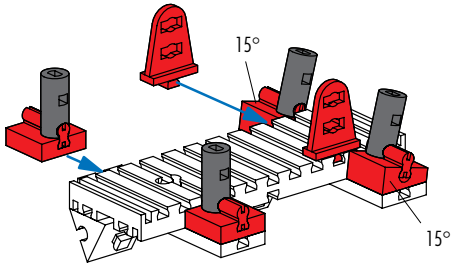
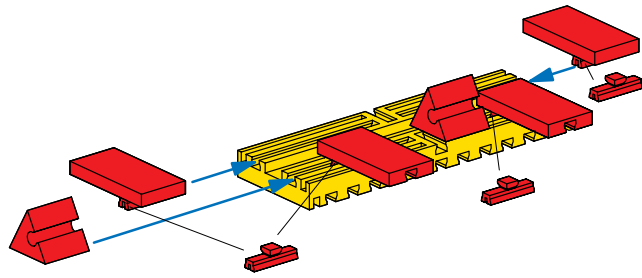
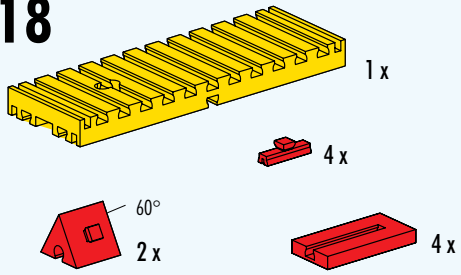

19

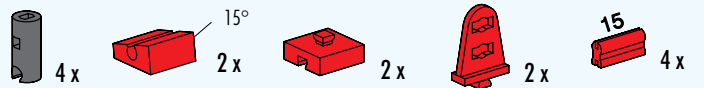

20

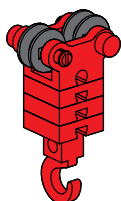
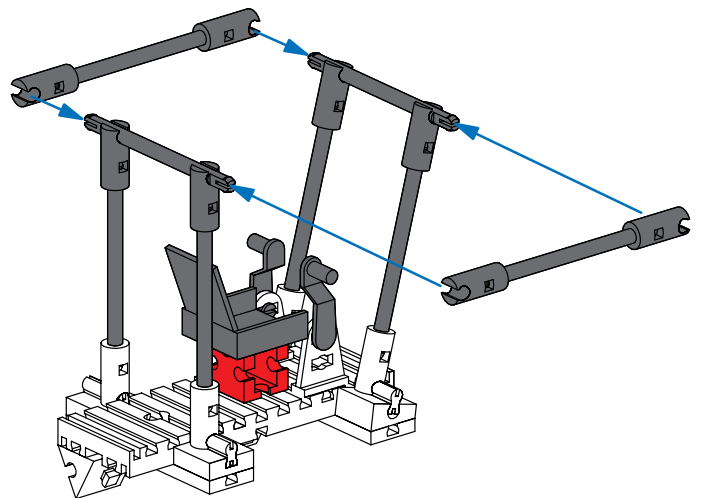
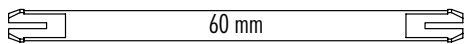
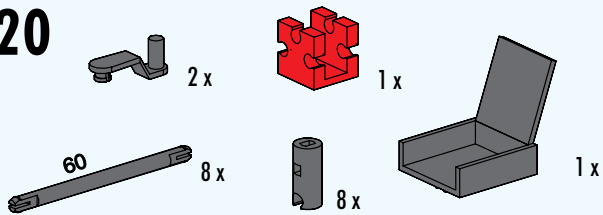

21



Seilführung
Cable guide
Guidage par câbles

Touwgeleiding
Conducción del cable
Guia da corda

Kranhaken
Crane hook
Crochet

Kraanhaak
Gancho de grúa
Gancho da grua

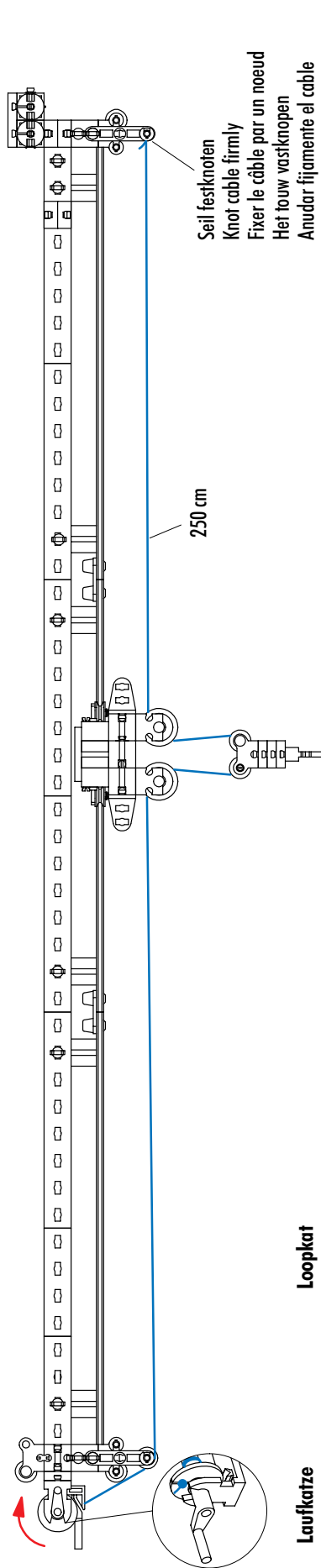

Seil festknöten
Knot cable firmly
Fixer le câble par un noeud
Het touw vastknopen
Anudar firmemente el cable
Fixar corda mediante nó

250 cm

Laufkatze
Crab
Charriot de pont roulant

Loopkat
Carro
Carrinho para talha

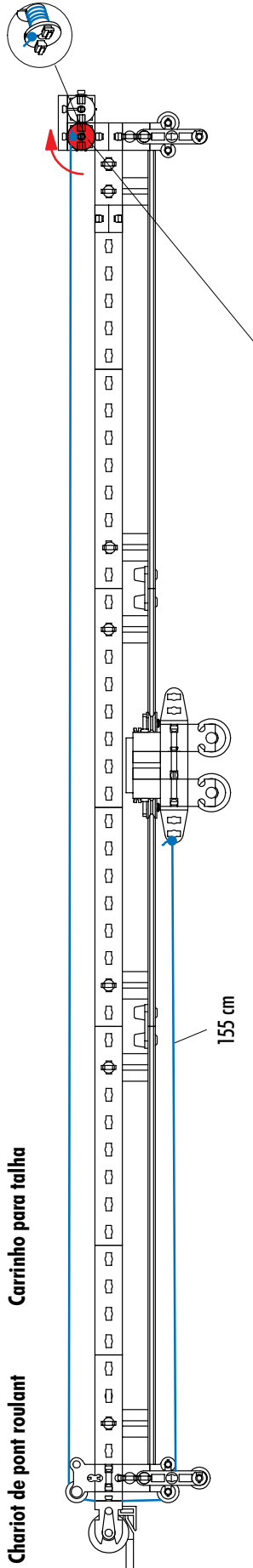

155 cm

Beim Aufwickeln des Seils Drehrichtung beachten!
Note direction of rotation when winding the cable!
Observer le sens de rotation lors de l'enroulement du câble!
Tijdens het oprollen van het touw de draairichting in acht nemen!
Tener en cuenta el sentido de rotación al enrollar el cable!
Ao enrolar a corda, observar o sentido de rotação!

Seil spannen und Zahnrad aufstecken
Tighten cable and fit gear wheel
Tendre le câble et emboîter la roue dentée
Het touw opspannen en het tandwiel aanbrengen
Tensor el cable y encajar la rueda dentada
Esticar corda e montar a roda dentada

Laufkatze
Crab
Charriot de pont roulant

Loopkat
Carro
Carrinho para talha

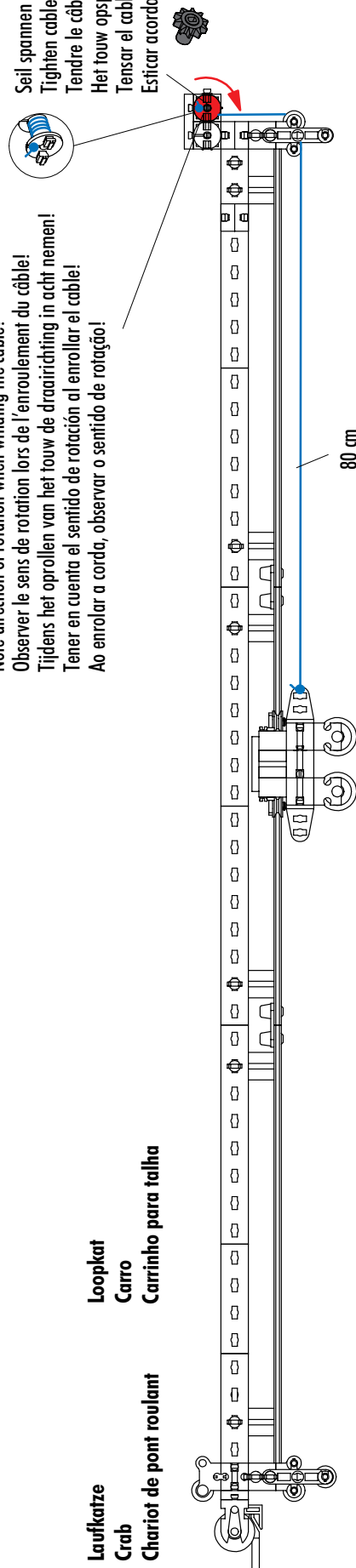

80 cm

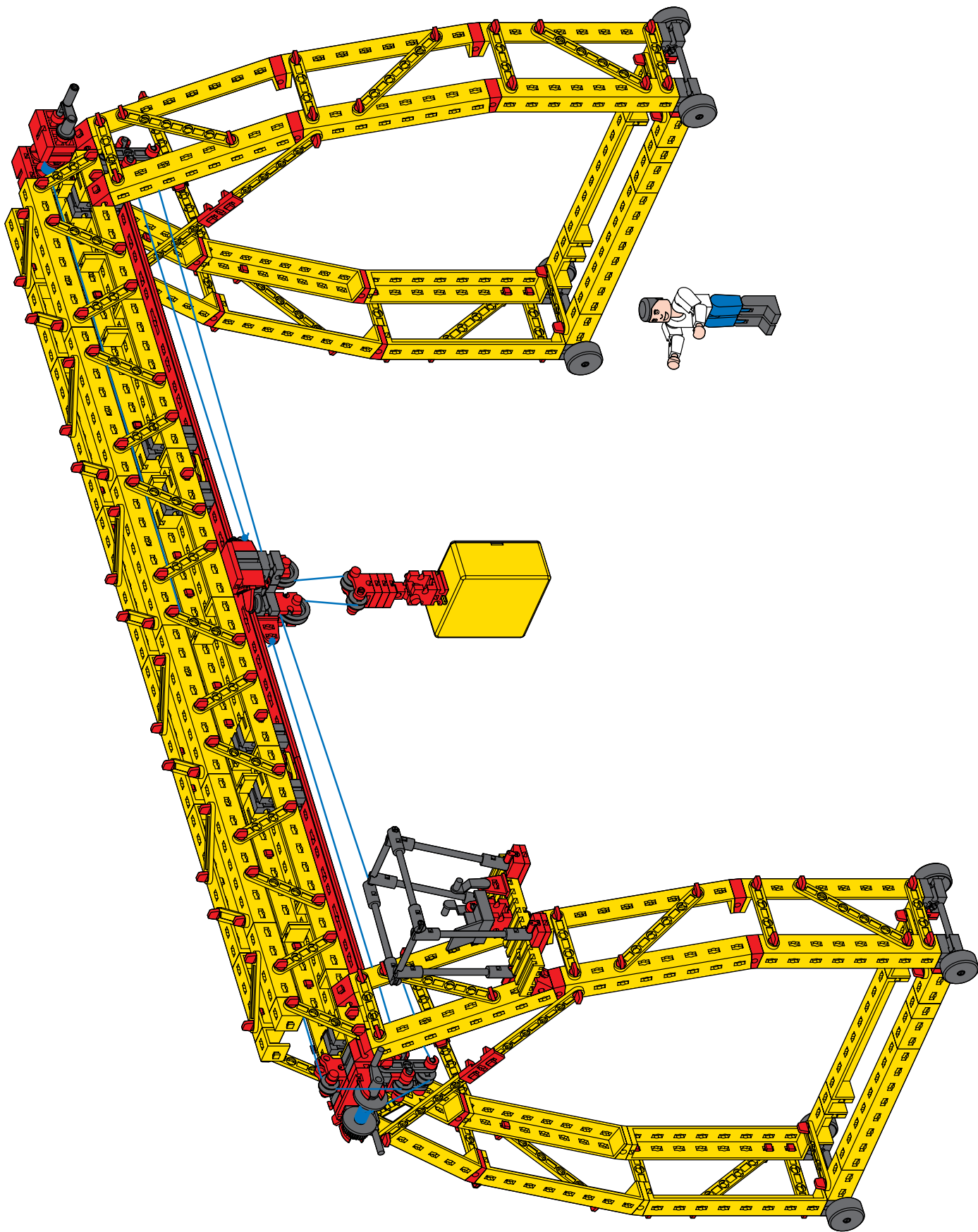

Motorisierung und Fernsteuerung
Motorization and remote control
Motorisation et télécommande

Laufkatze
 Crab
 Chariot de pont roulant

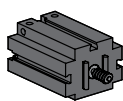

Loopkat
 Carro
 Carrinho para talha

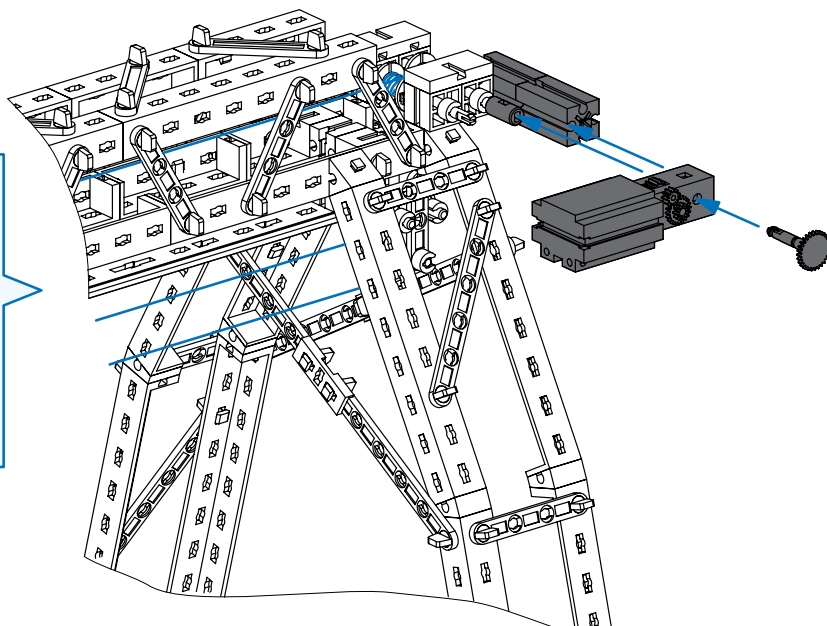
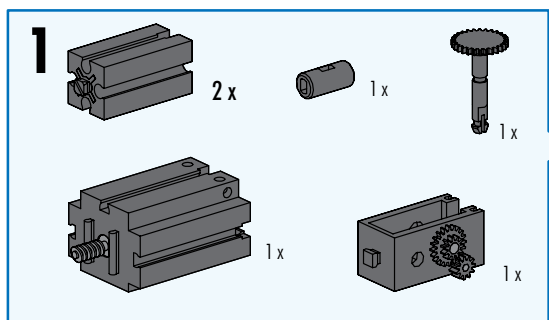
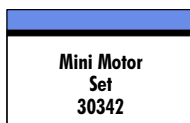

Kranhaken
 Crane hook
 Crochet

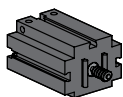

Kraanhaak
 Gancho de grúa
 Gancho da grua

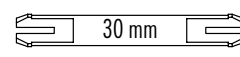
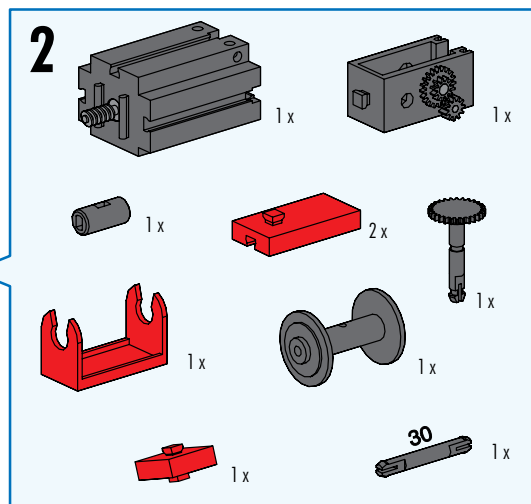
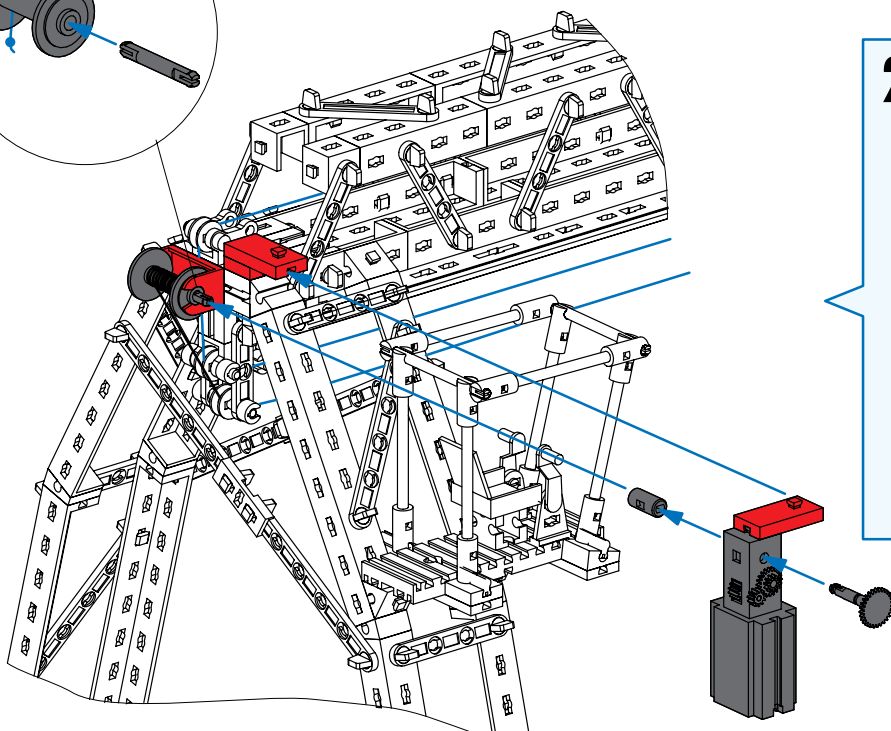
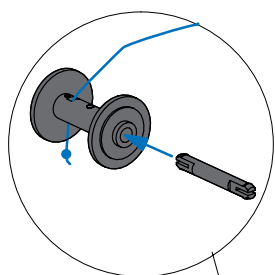
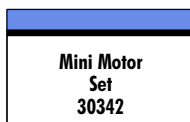

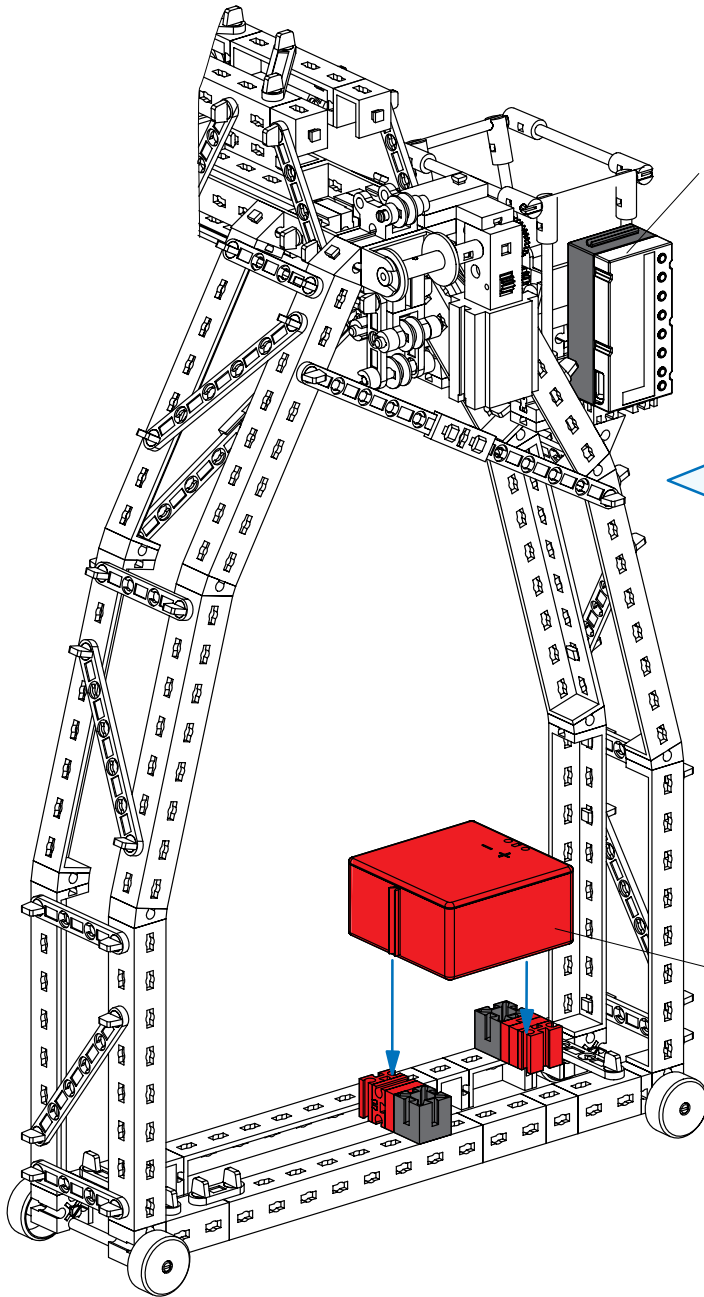

IR Control Set 30344

Fernsteuerung
Remote control
Télécommande

Afstandsbesturing
Mando a distancia
Telecomando

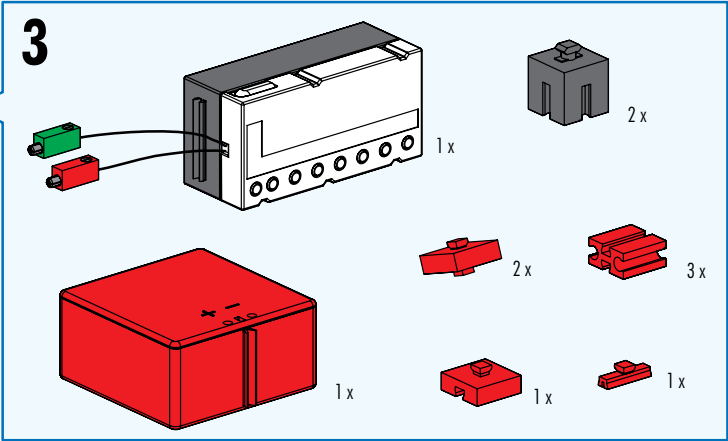

Accu Set 34969

Stromversorgung
Power supply
Alimentation électrique

Stroomvoorziening
Alimentación de corriente
Alimentação elétrica

Schaltplan
Circuit diagram
Plan électrique

Schakelschema
Diagrama de circuitos
Plano elétrico de ligação

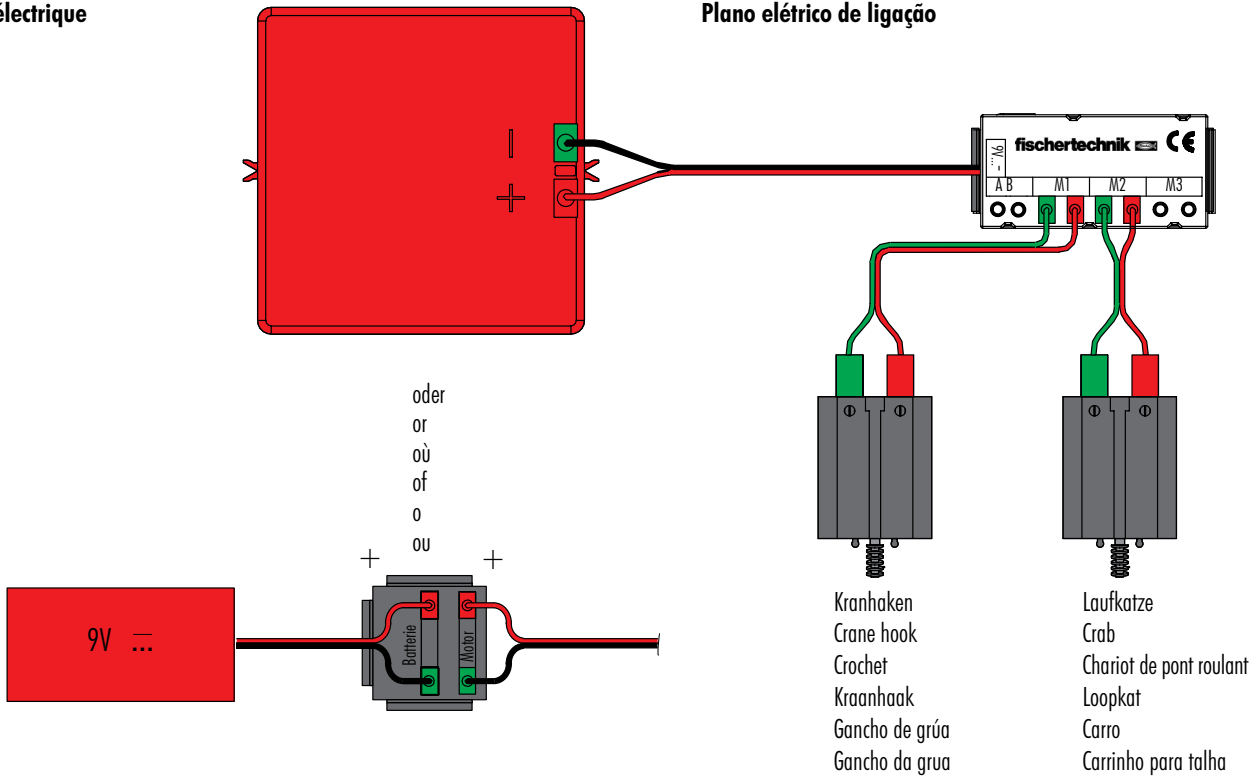

Schwerlastkran
Heavy-duty crane
Grue pour charges lourdes

Kraan voor zware lasten
Grúa para cargas pesadas
Guindaste titan

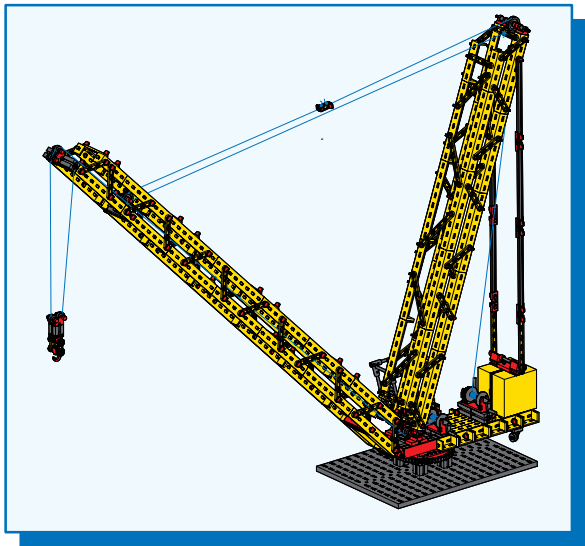

1

1 x

4 x

2 x

2 x

6 x

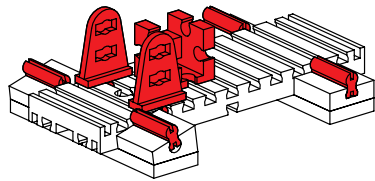
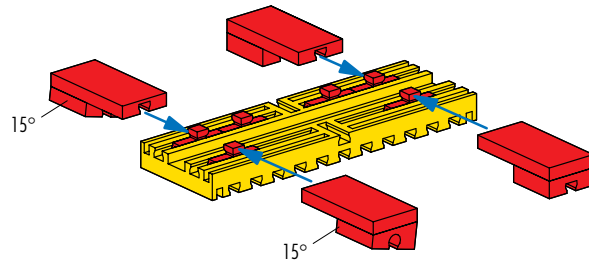

2

4 x

2 x

1 x

3

1 x

2 x

8 x

12 x

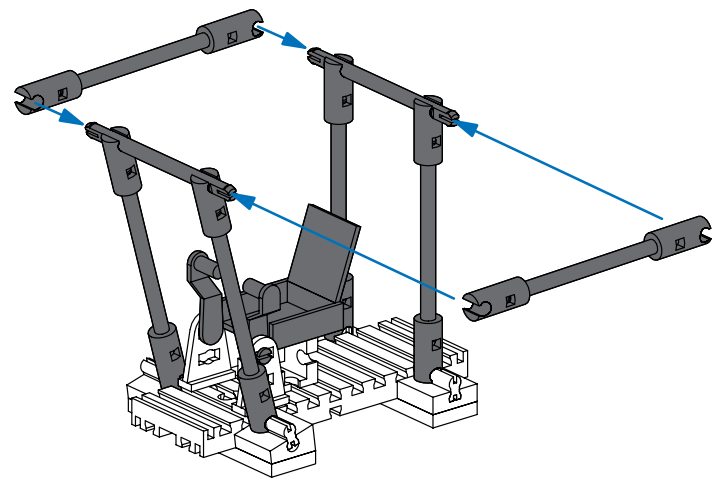
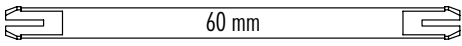

4

1 x

4 x

2 x

2 x

4 x

2 x

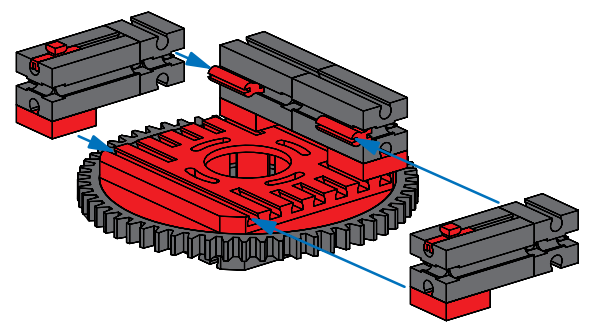

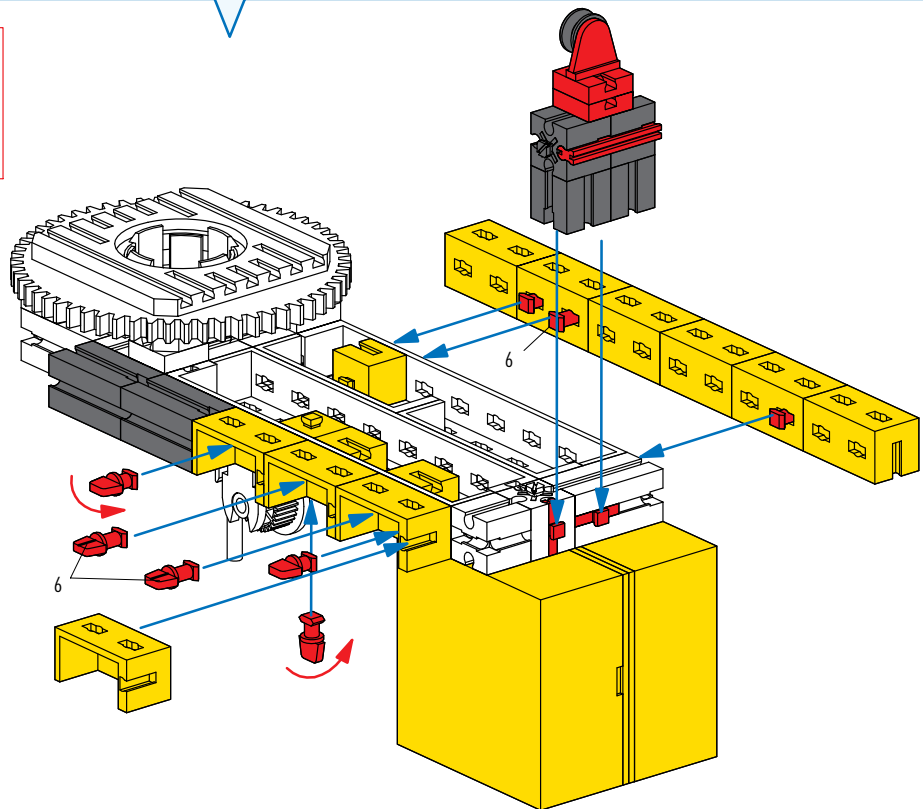
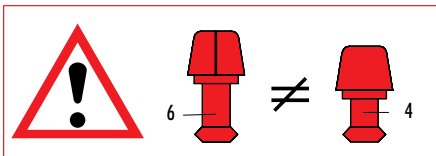
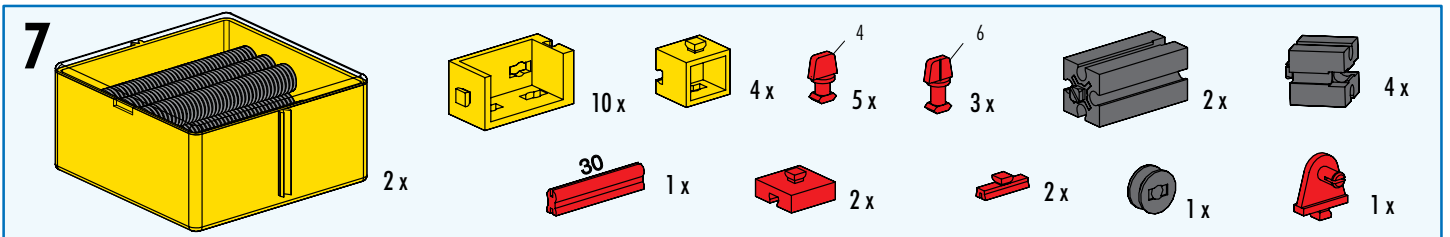
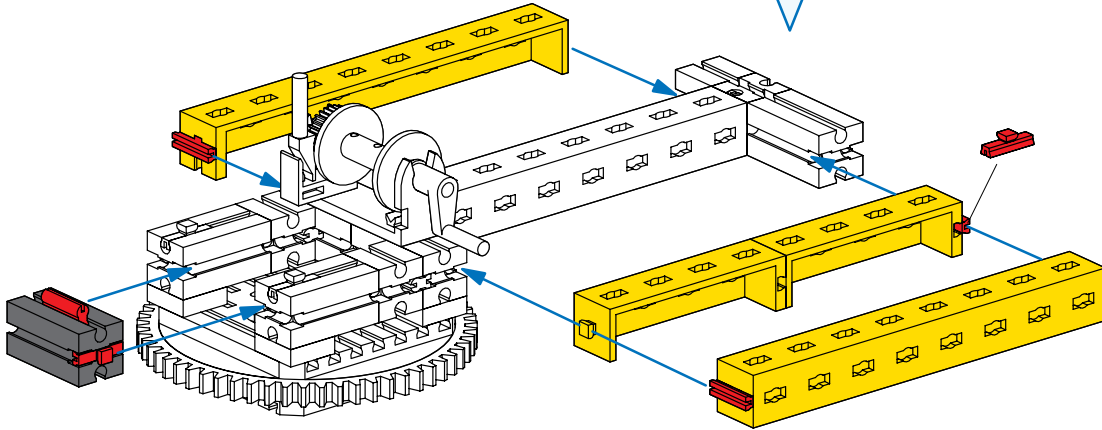
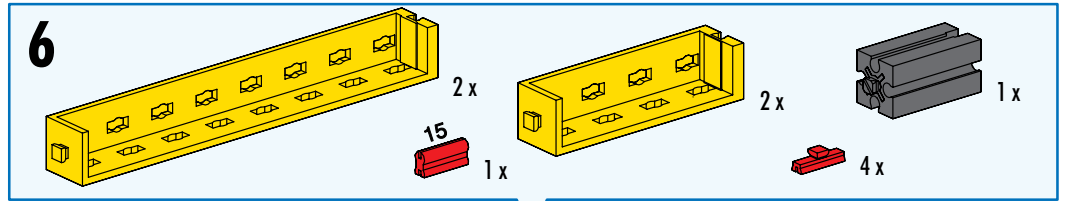
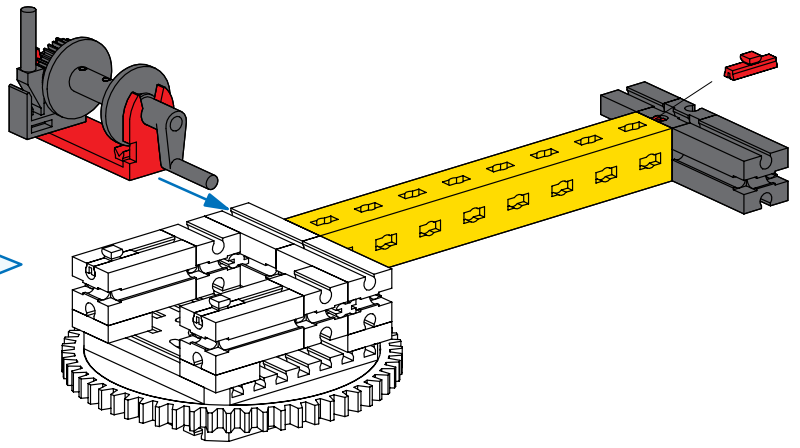
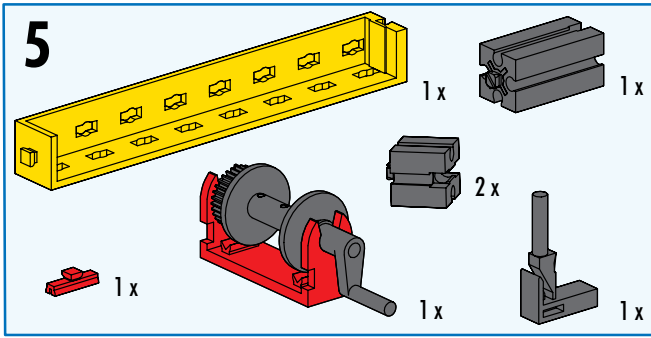

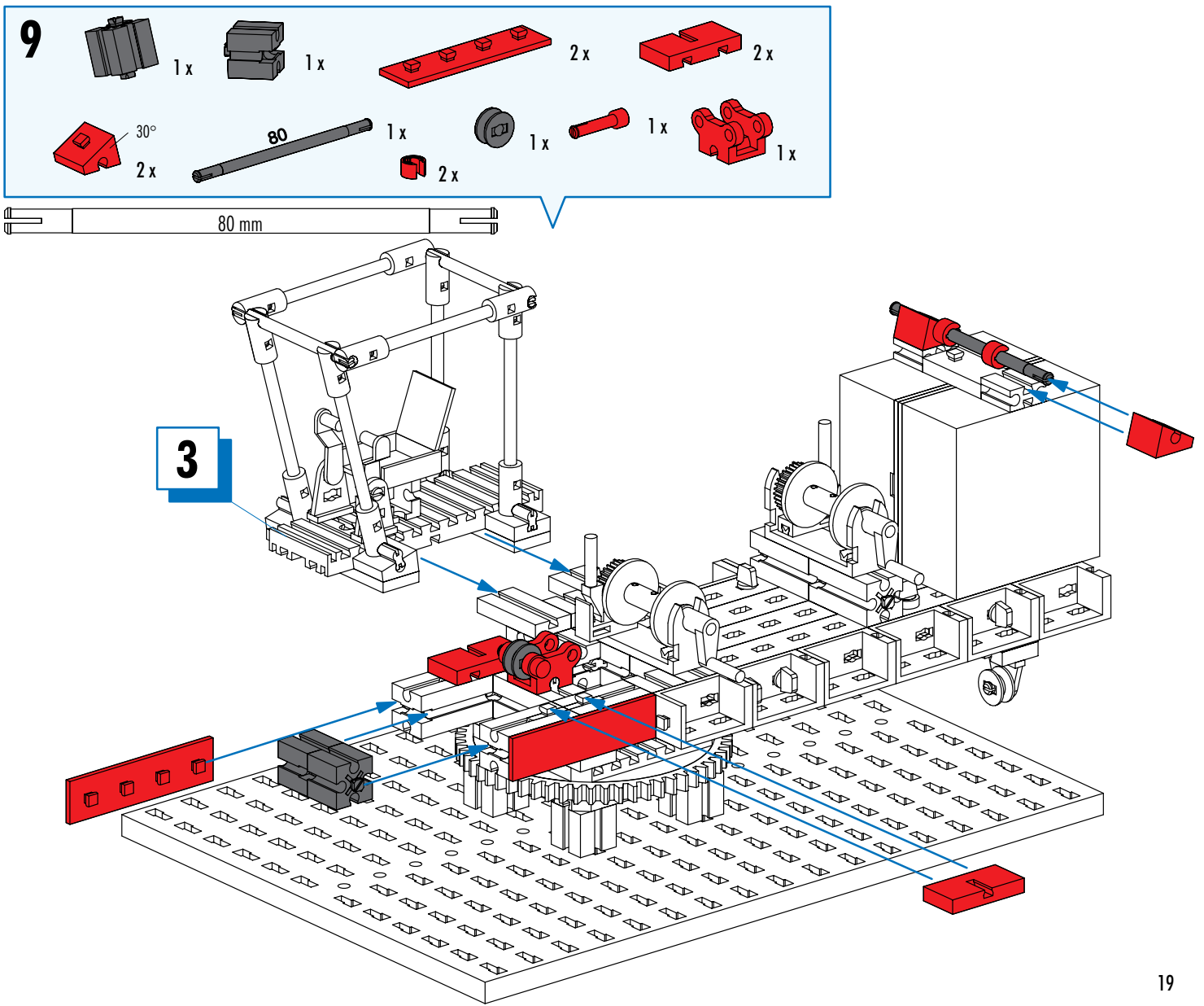
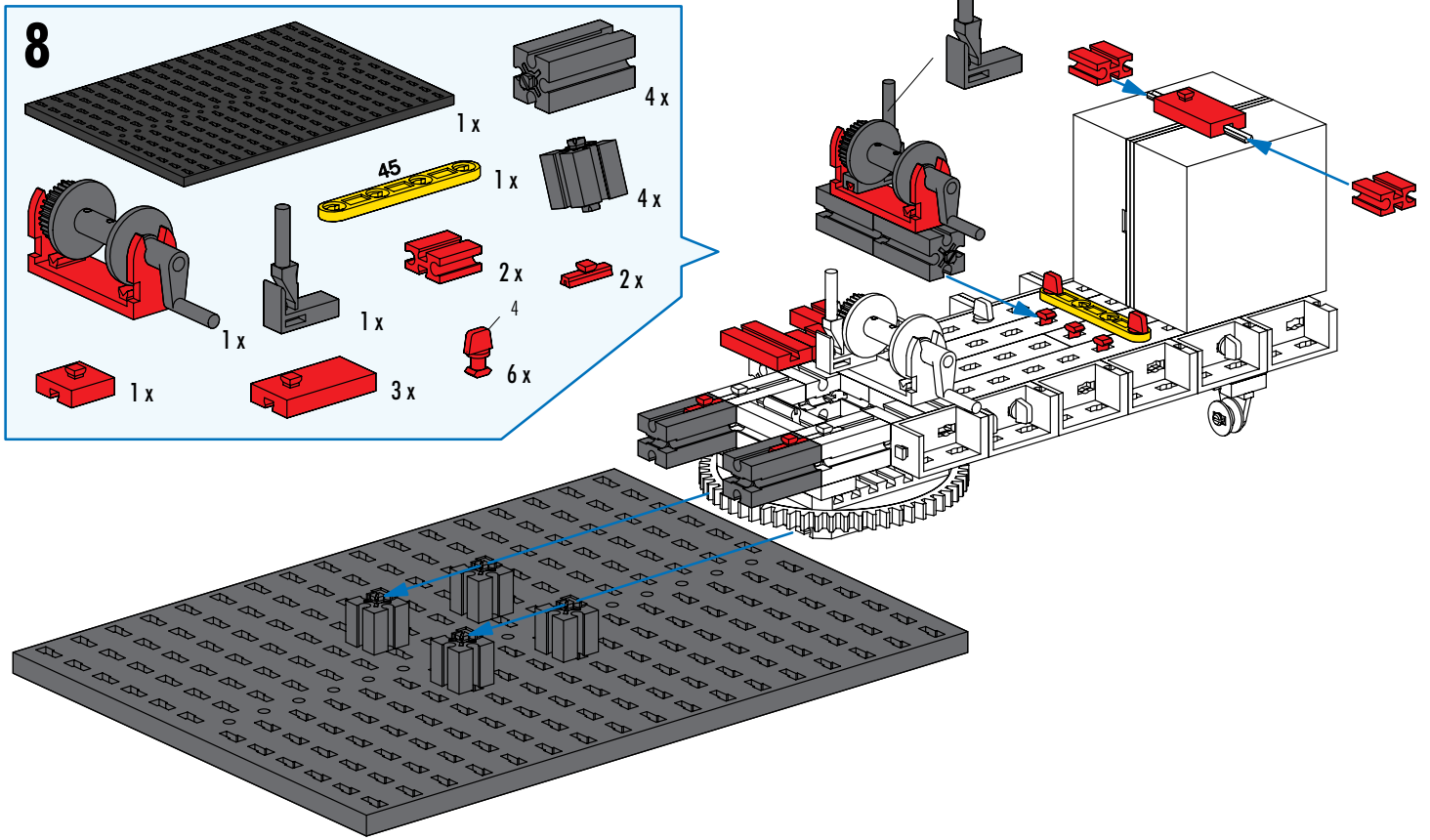

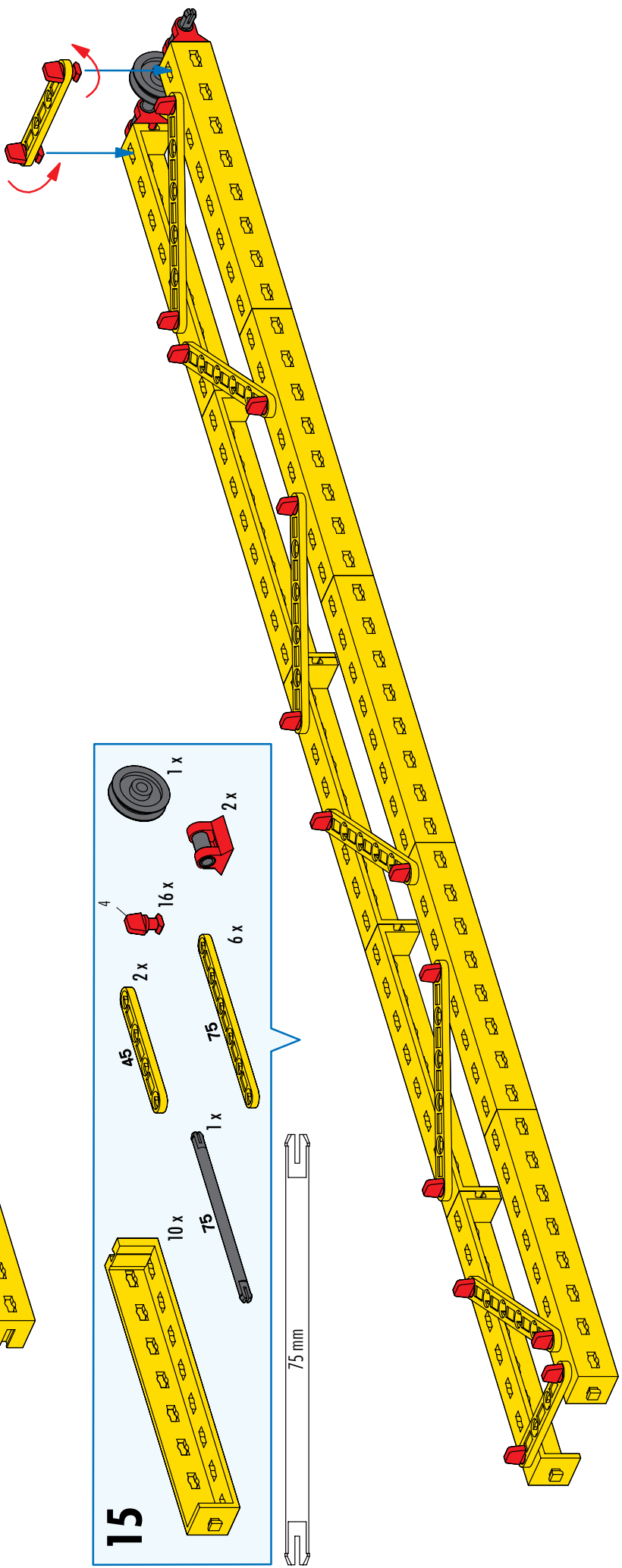
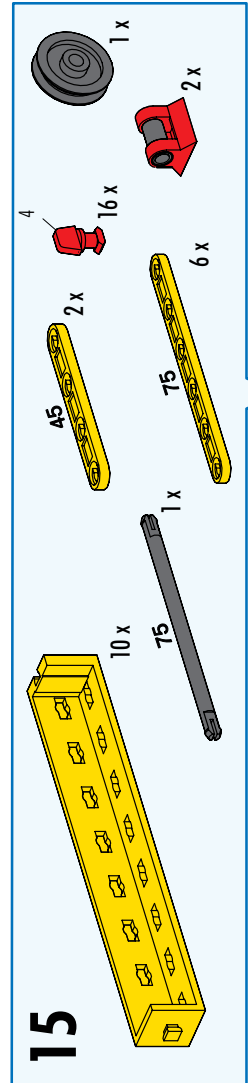
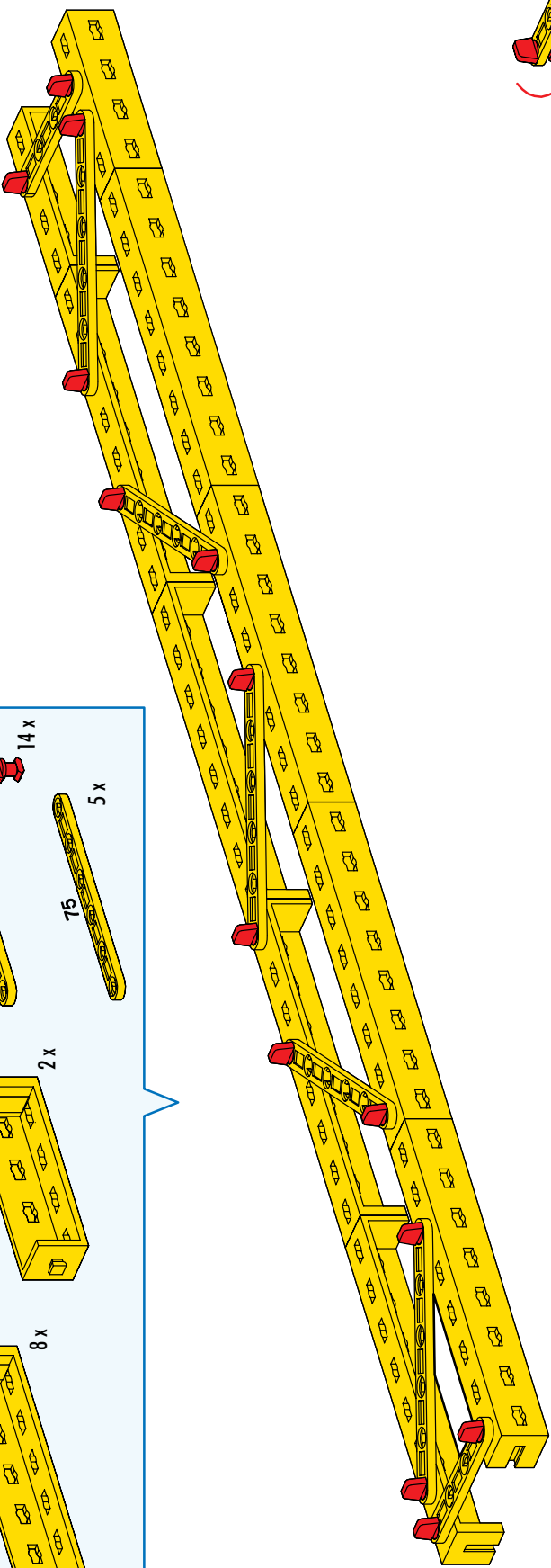
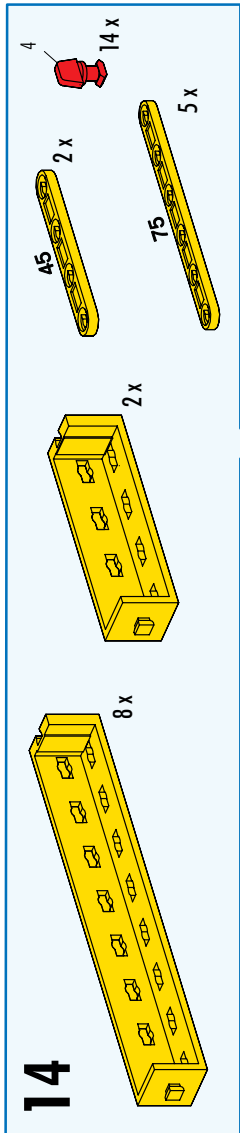

14

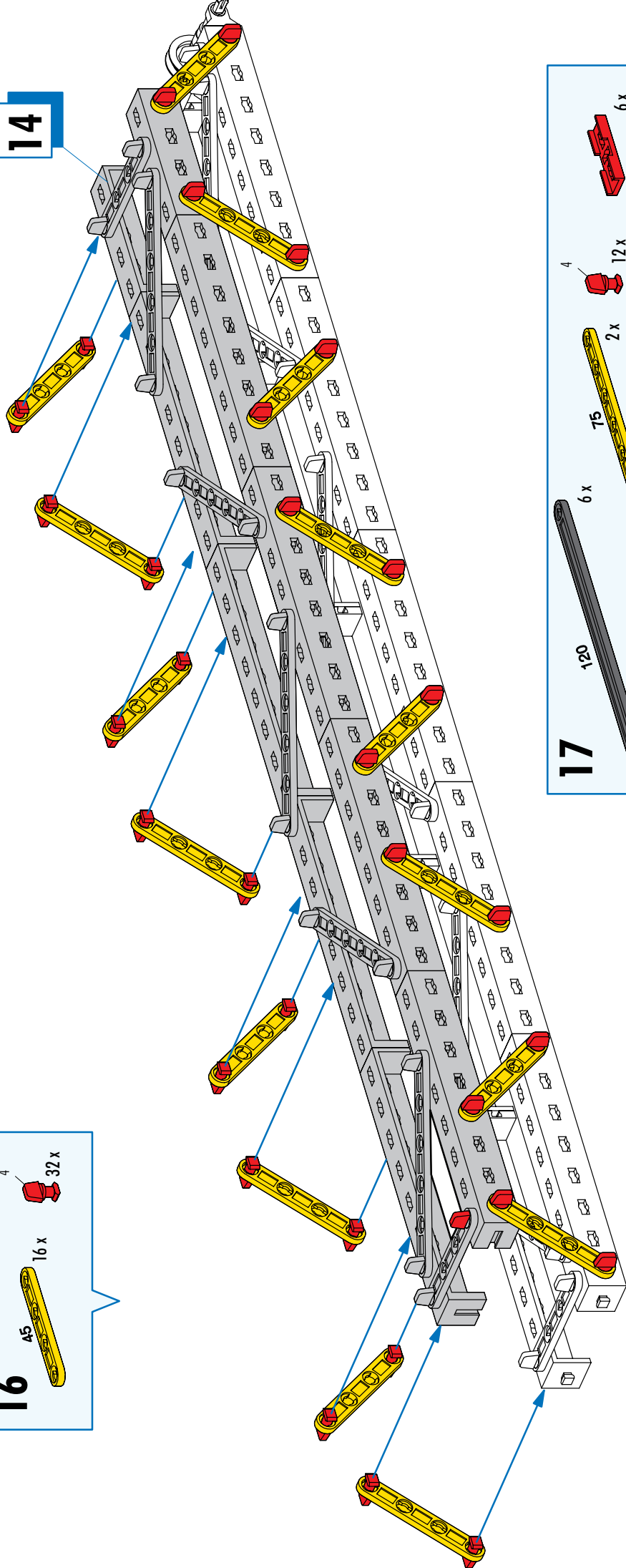

17

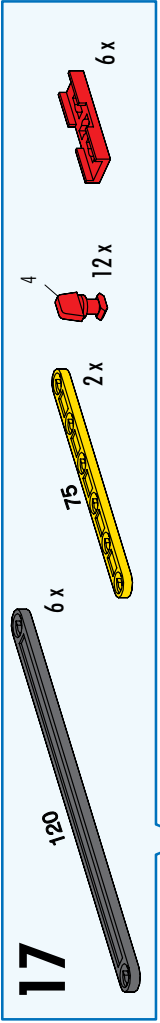

2 x

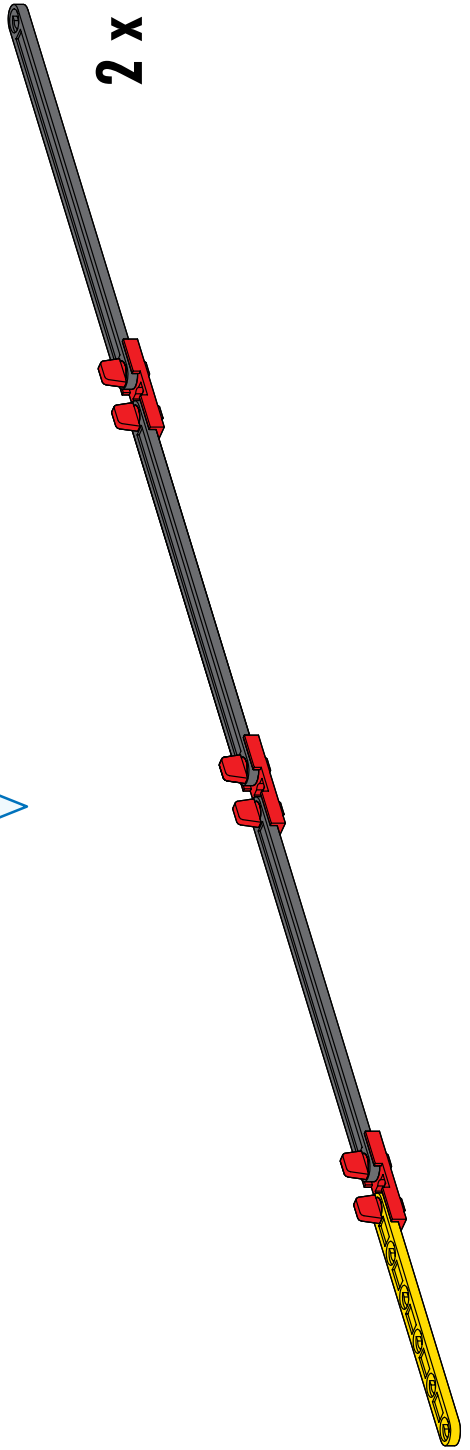

16

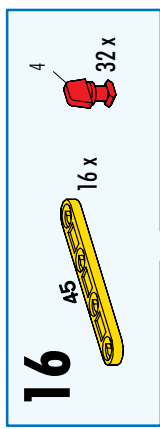

18

2 x 6 x 4 2 x

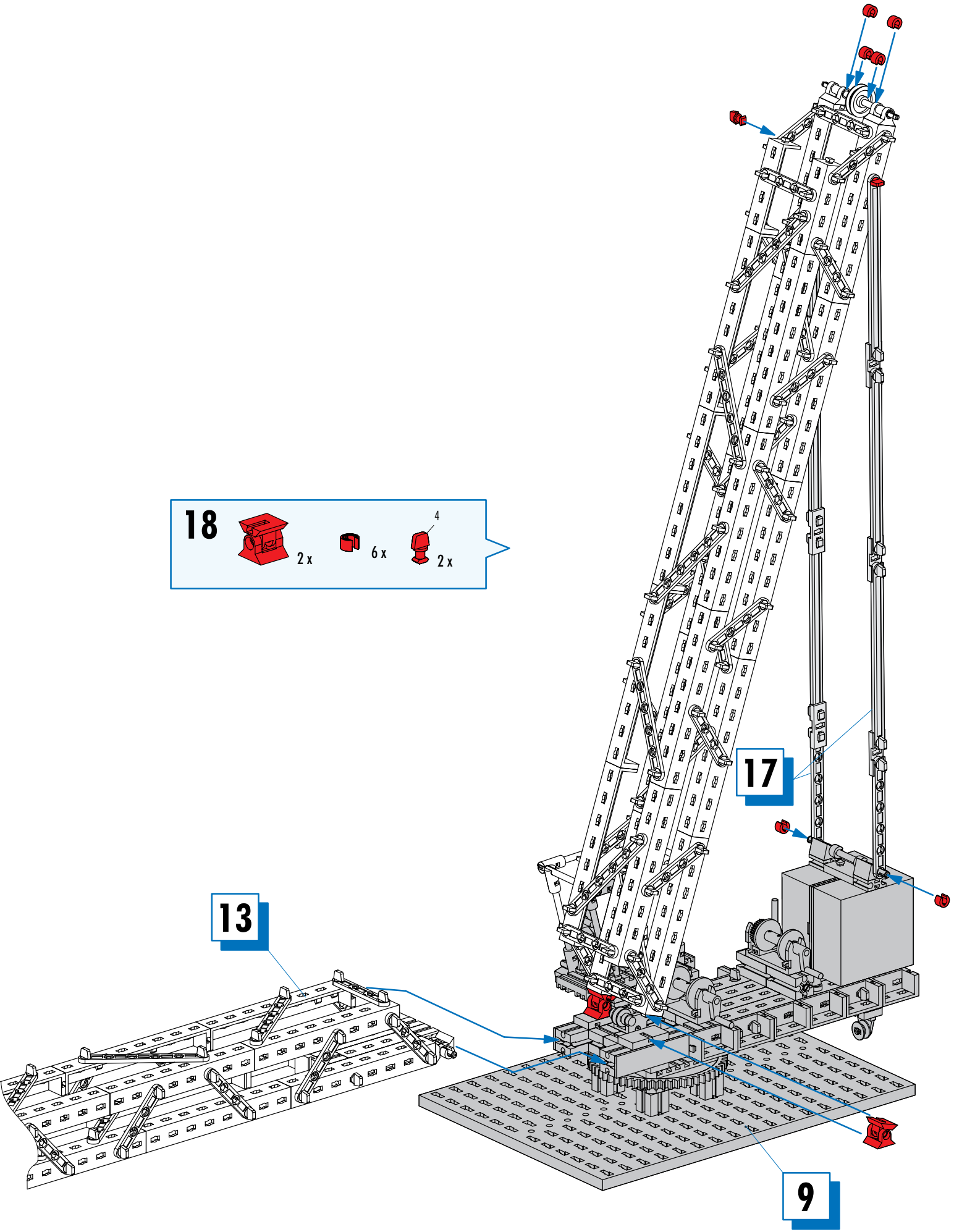

19

	1 x		1 x		1 x		1 x
	2 x		2 x		2 x		1 x
	2 x		2 x		4 x		1 x

30 mm

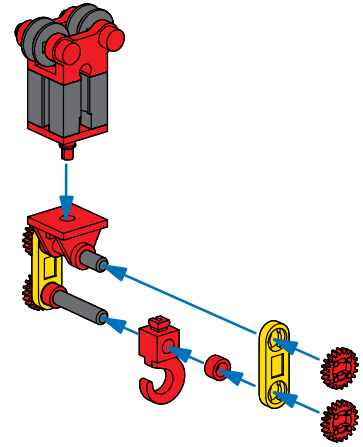

20

	2 x		2 x
--	-----	--	-----

250 cm 105 cm 155 cm

1 x 1 x 1 x

Seilführung siehe Seite 26
 Cable guide see page 26
 Guidage par câbles voir page 26
 Zie voor de touwgeleiding pagina 26
 Conducción del cable ver página 26
 Guia da corda, ver página 26

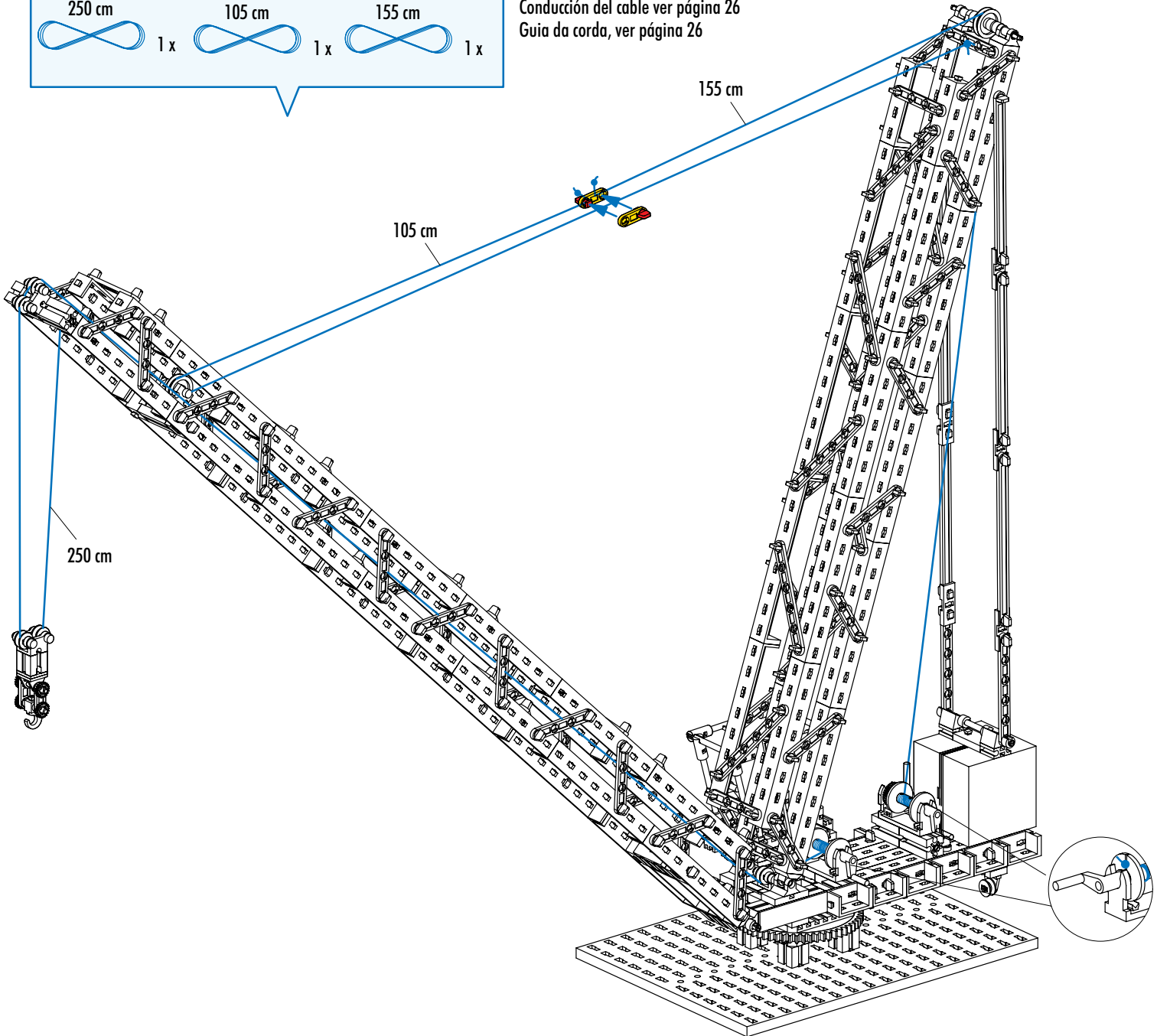

Seilführung
Cable guide
Guidage par câbles

Touwgeleiding
Conducción del cable
Guia da corda

Seil festknoten
 Knot cable firmly
 Fixer le câble par un noeud
 Het touw vastknopen
 Anudar fijamente el cable
 Fixar corda mediante nó

Ausleger
 Jib
 Flèche

Giek
 Brazo
 Lança

105 cm

155 cm

Kranhaken
 Crane hook
 Crochet

Kraanhaak
 Gancho de grúa
 Gancho da grua

Seil festknoten
 Knot cable firmly
 Fixer le câble par un noeud
 Het touw vastknopen
 Anudar fijamente el cable
 Fixar corda mediante nó

250 cm

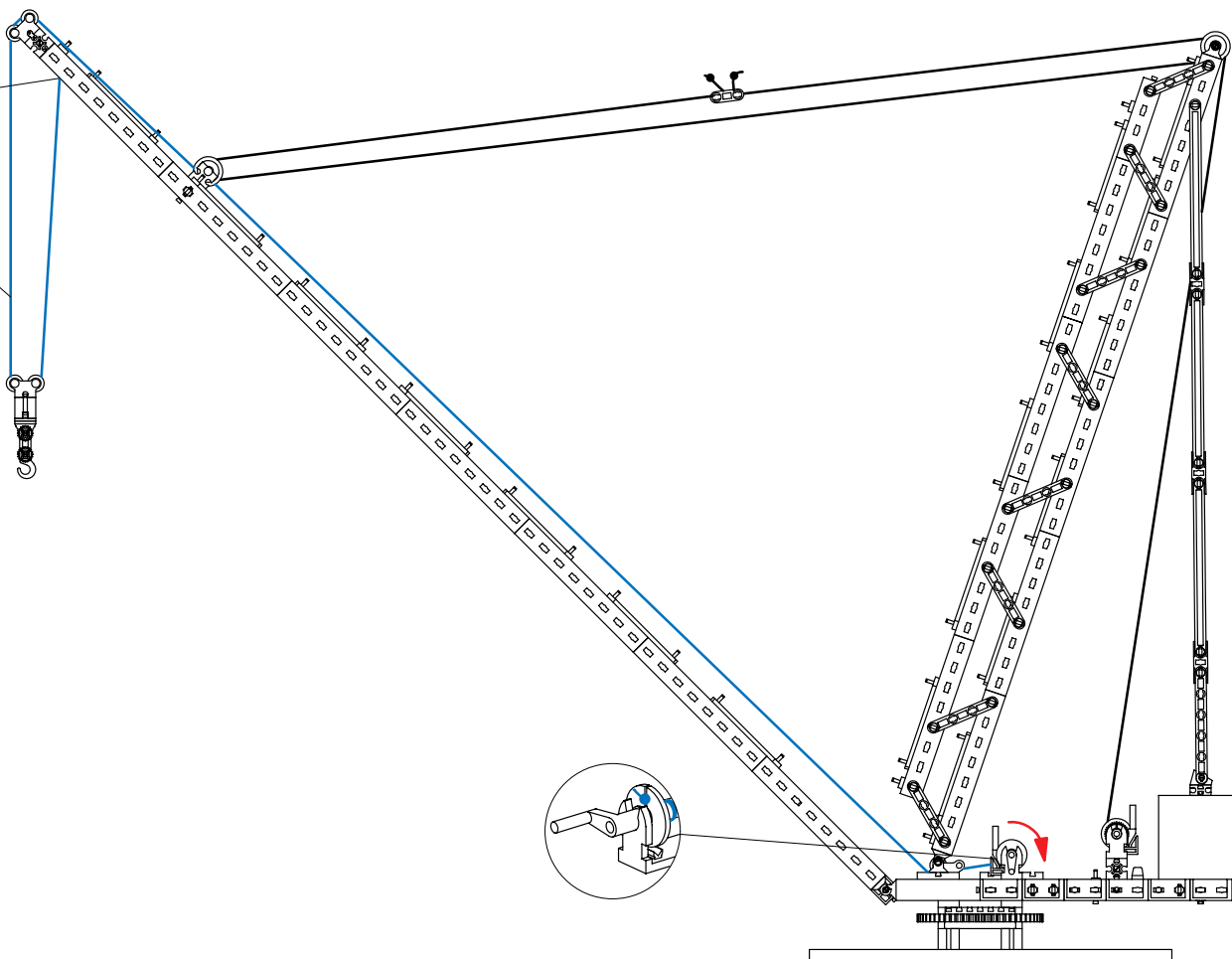

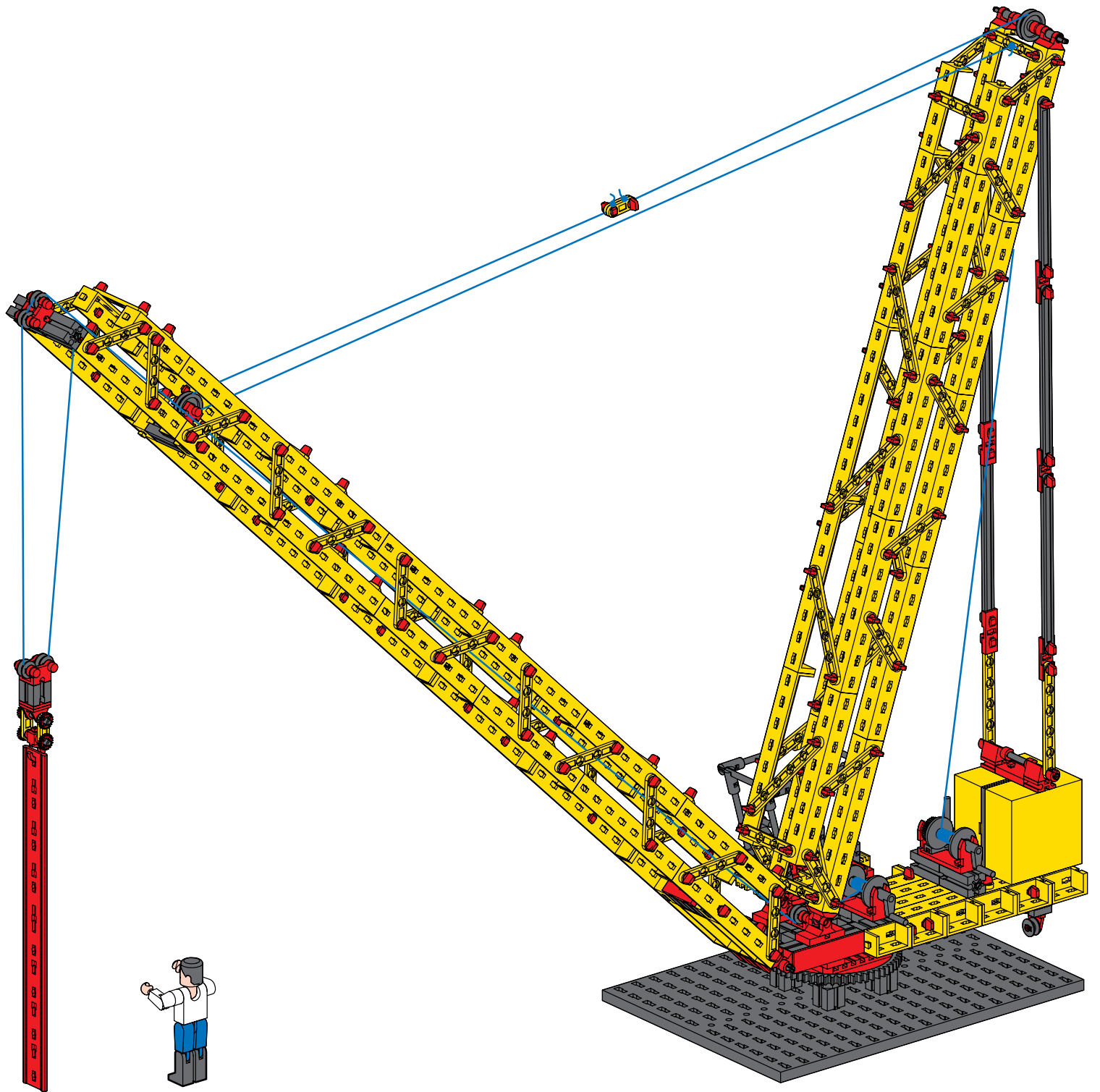

Motorisierung und Fernsteuerung
Motorization and remote control
Motorisation et télécommande

Drehkranz
 Slewing ring
 Couronne d'orientation

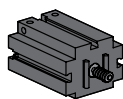

Schamelstel
 Corona giratoria
 Coroa rotativa

Motorisering en afstandsbesturing
Motorización y mando a distancia
Motorização e telecomando

Mini Motor
 Set
 30342

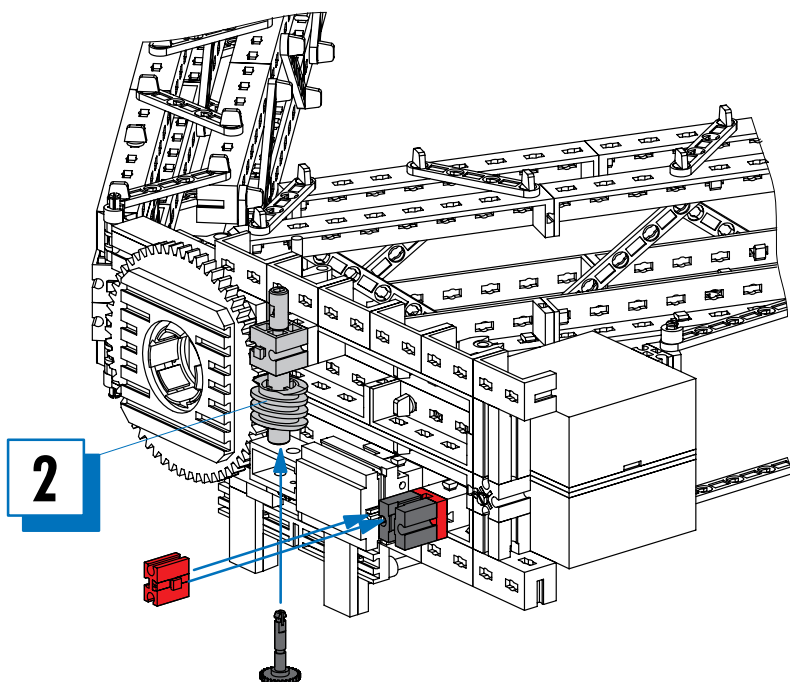
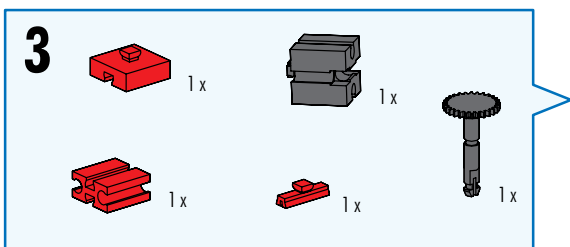
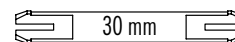
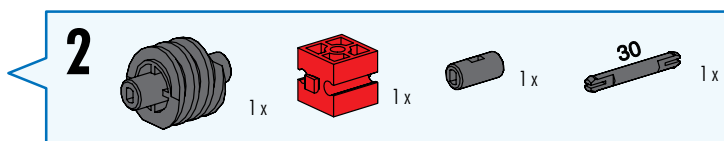
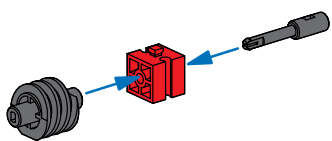
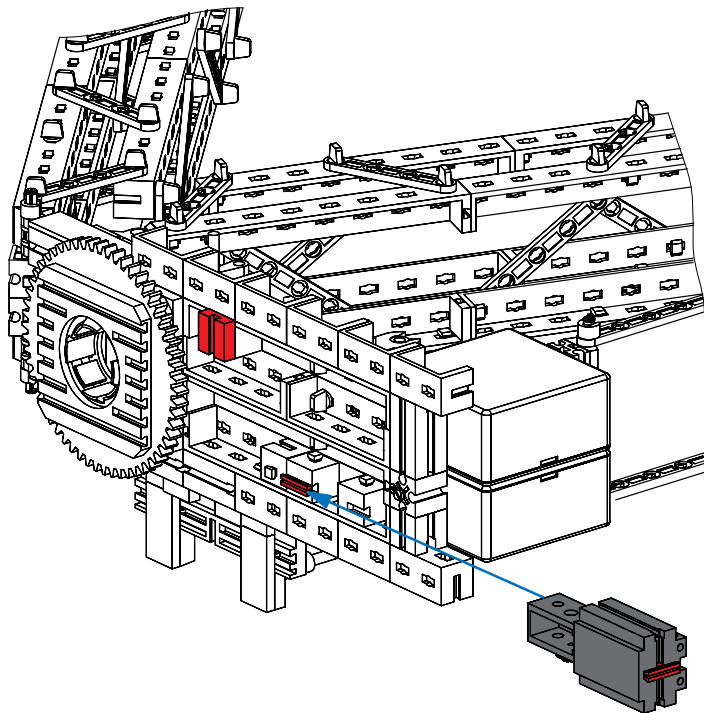
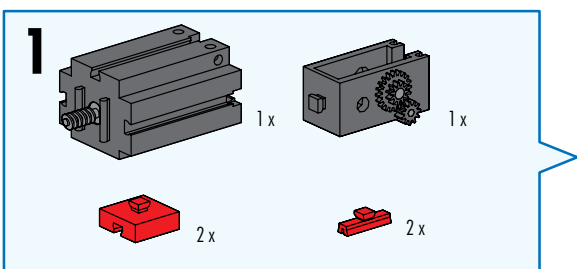

Ausleger
Jib
Flèche

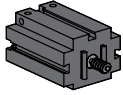

Giek
Braço
Lança

Mini Motor
Set
30342

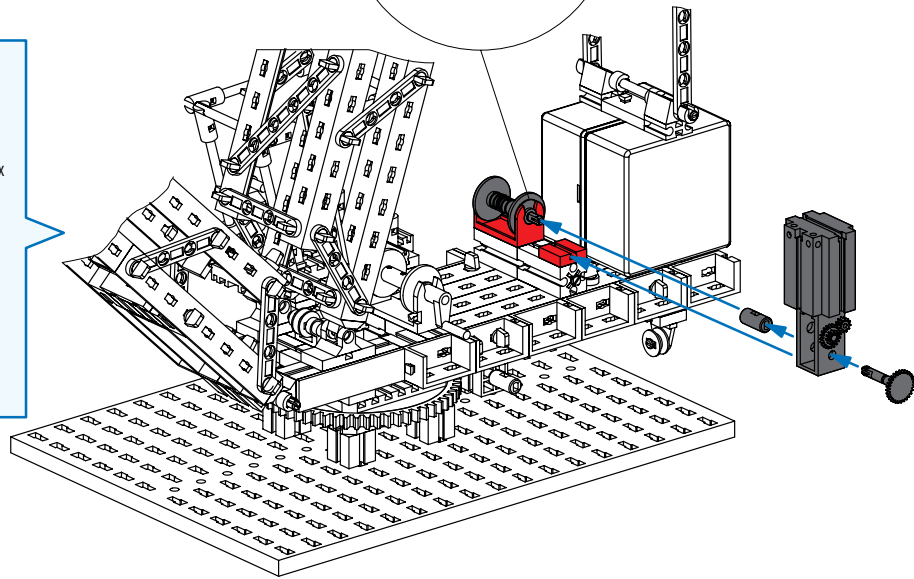
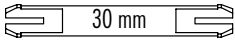
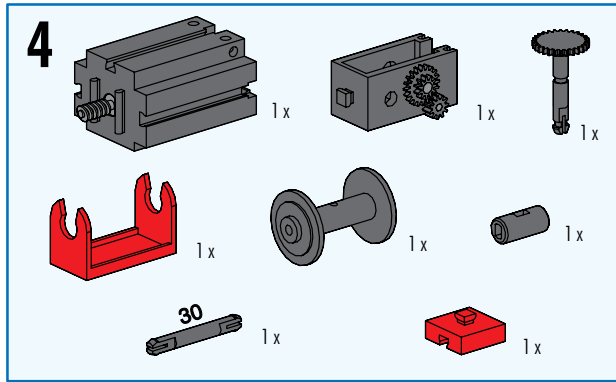

Kranhaken
Crane hook
Crochet

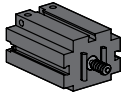

Kraanhaak
Gancho de grúa
Gancho da grua

Mini Motor
Set
30342

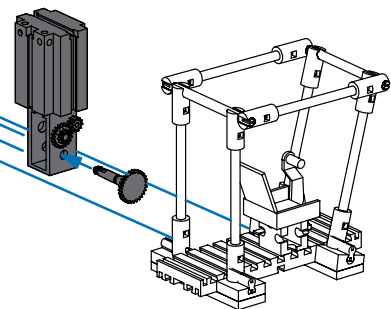
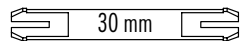
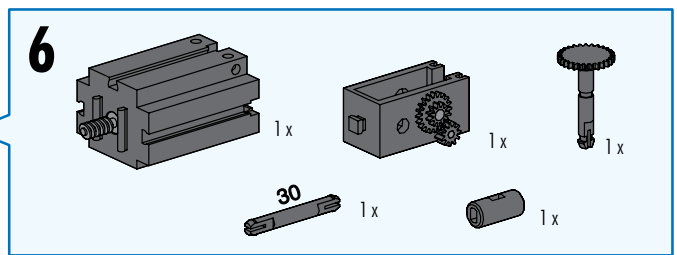
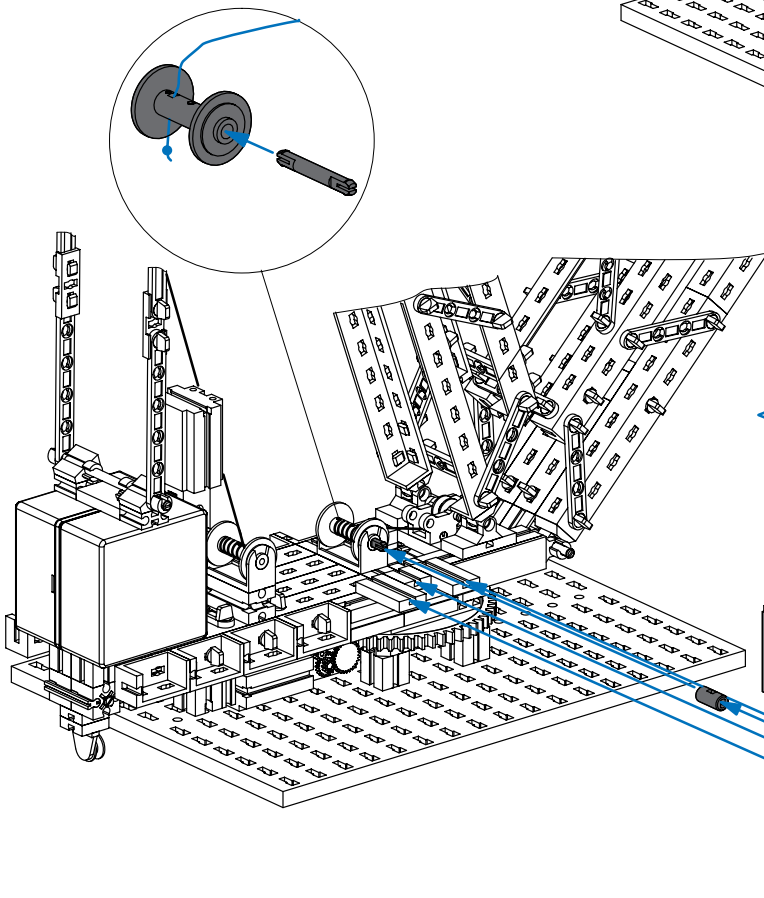
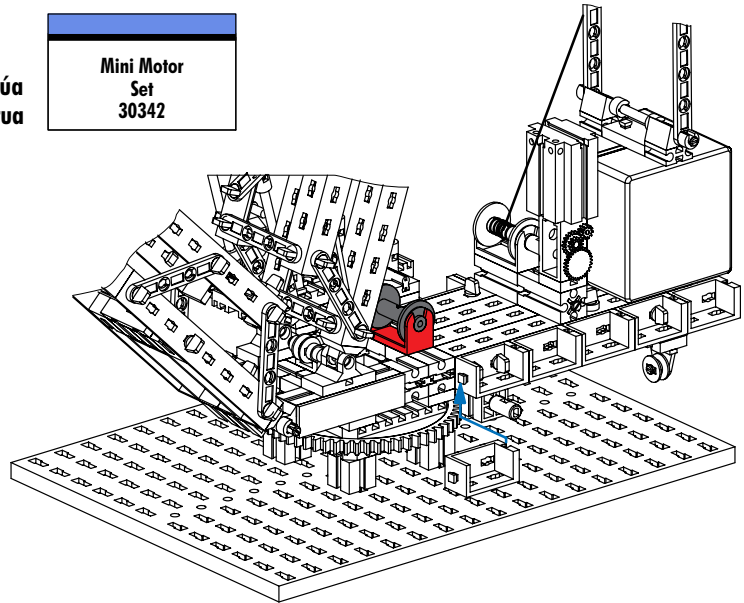
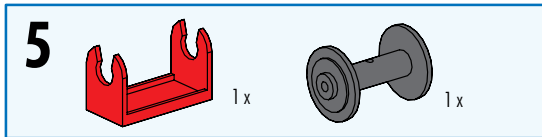

Stromversorgung
Power supply
Alimentation électrique

Stroomvoorziening
Alimentación de corriente
Alimentação elétrica

Accu
 Set
 34969

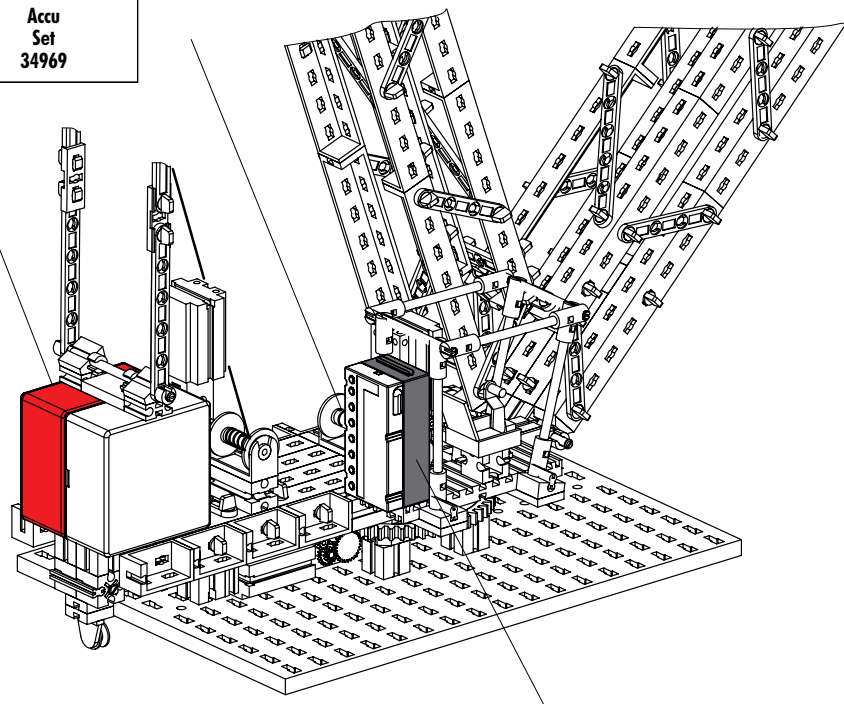
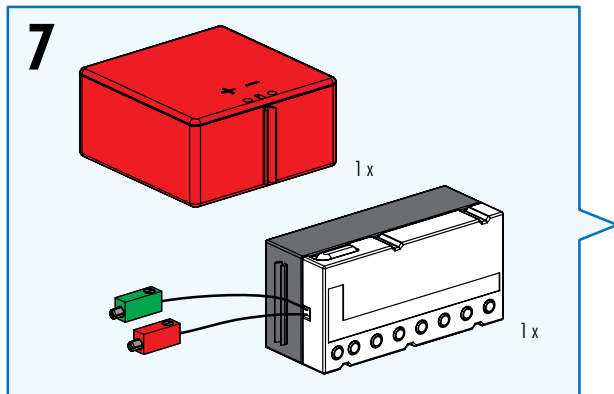

Fernsteuerung
Remote control
Télécommande

Afstandsbesturing
Mando a distancia
Telecomando

IR Control
 Set
 30344

Schaltplan
Circuit diagram
Plan électrique

Schakelschema
Diagrama de circuitos
Plano elétrico de ligação

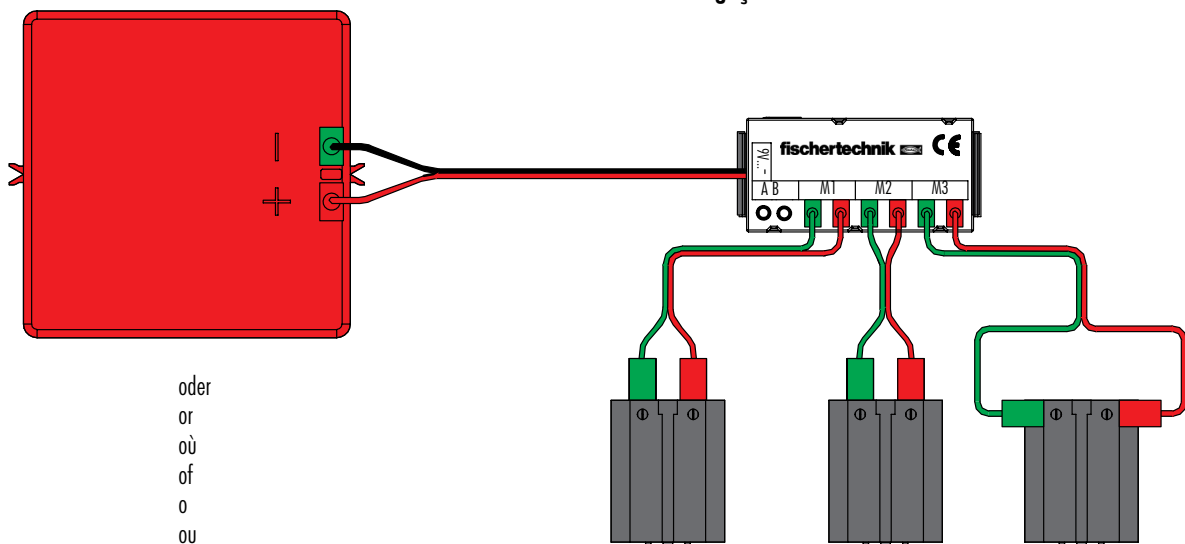

oder
 or
 ou
 of
 o
 ou

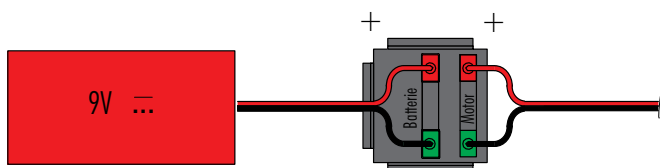

Kranhaken
 Crane hook
 Crochet
 Kraanhaak
 Gancho de grúa
 Gancho da grua

Laufkatze
 Chariot de pont roulant
 Loopkat
 Carro
 Carrinho para talha

Drehkranz
 Slewing ring
 Couronné d'orientation
 Schamelstel
 Corona giratoria
 Coroa rotativa

Baustellenkran
Building site crane
Grue de chantier

Bouwkraan
Grúa para obras
Guindaste giratório

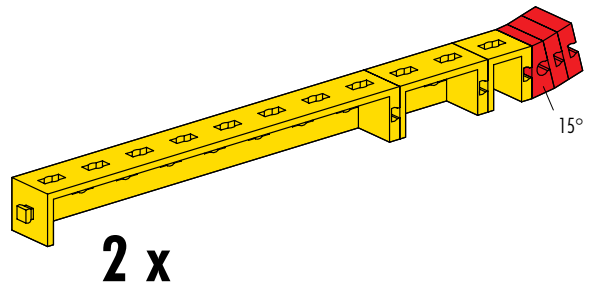
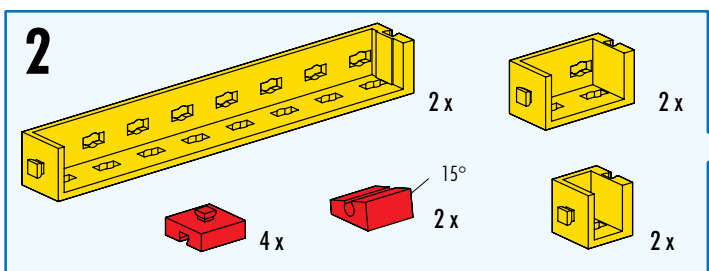
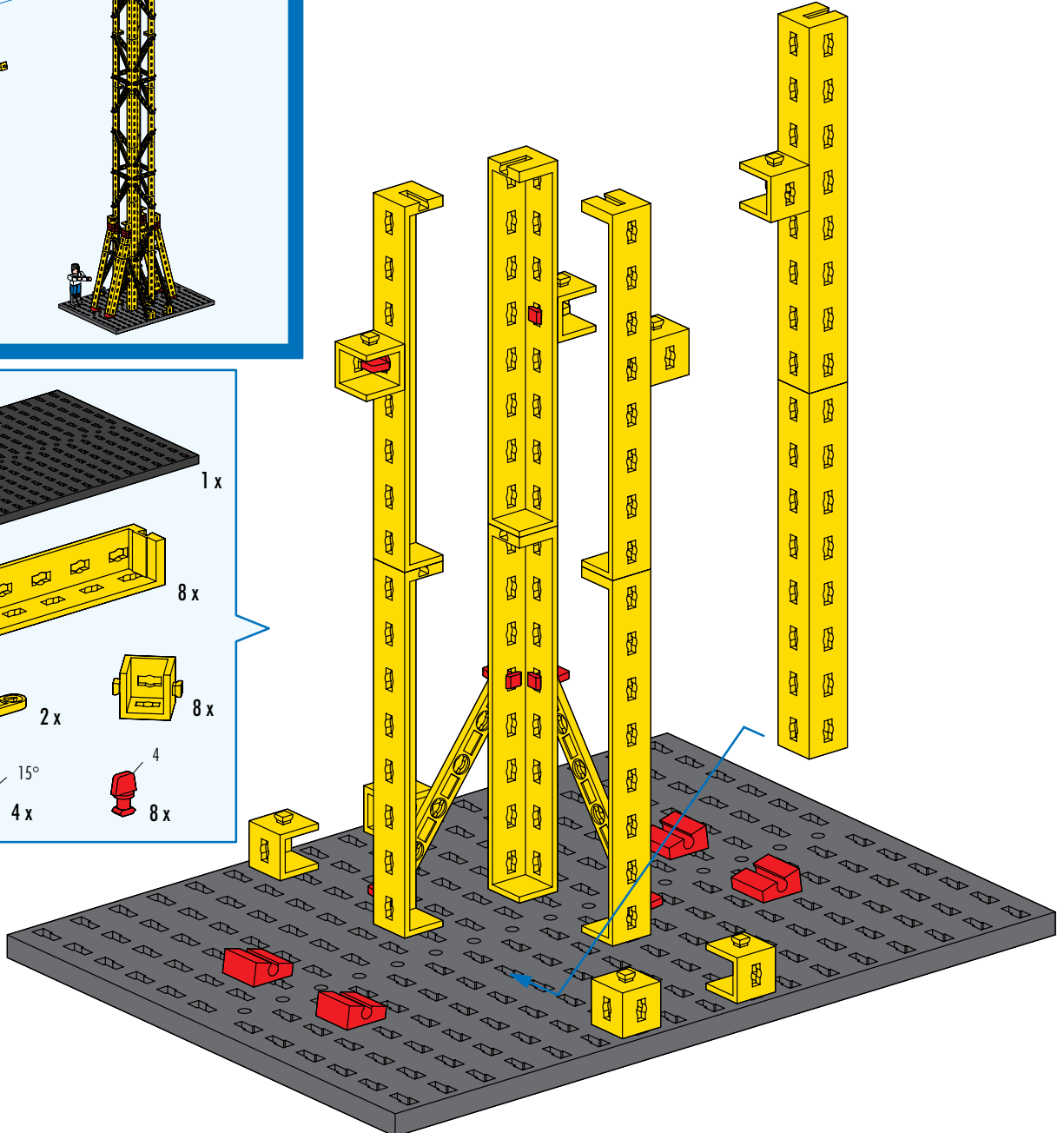
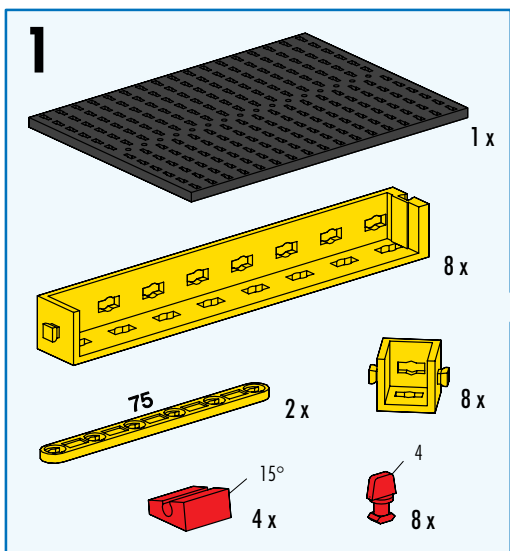

3

120 3 x 75 4 x 4 14 x

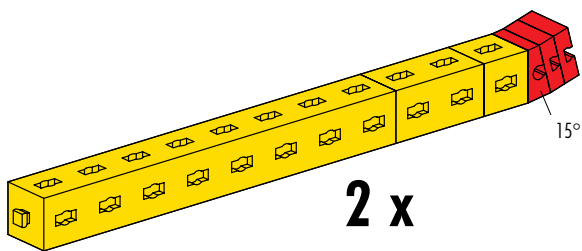
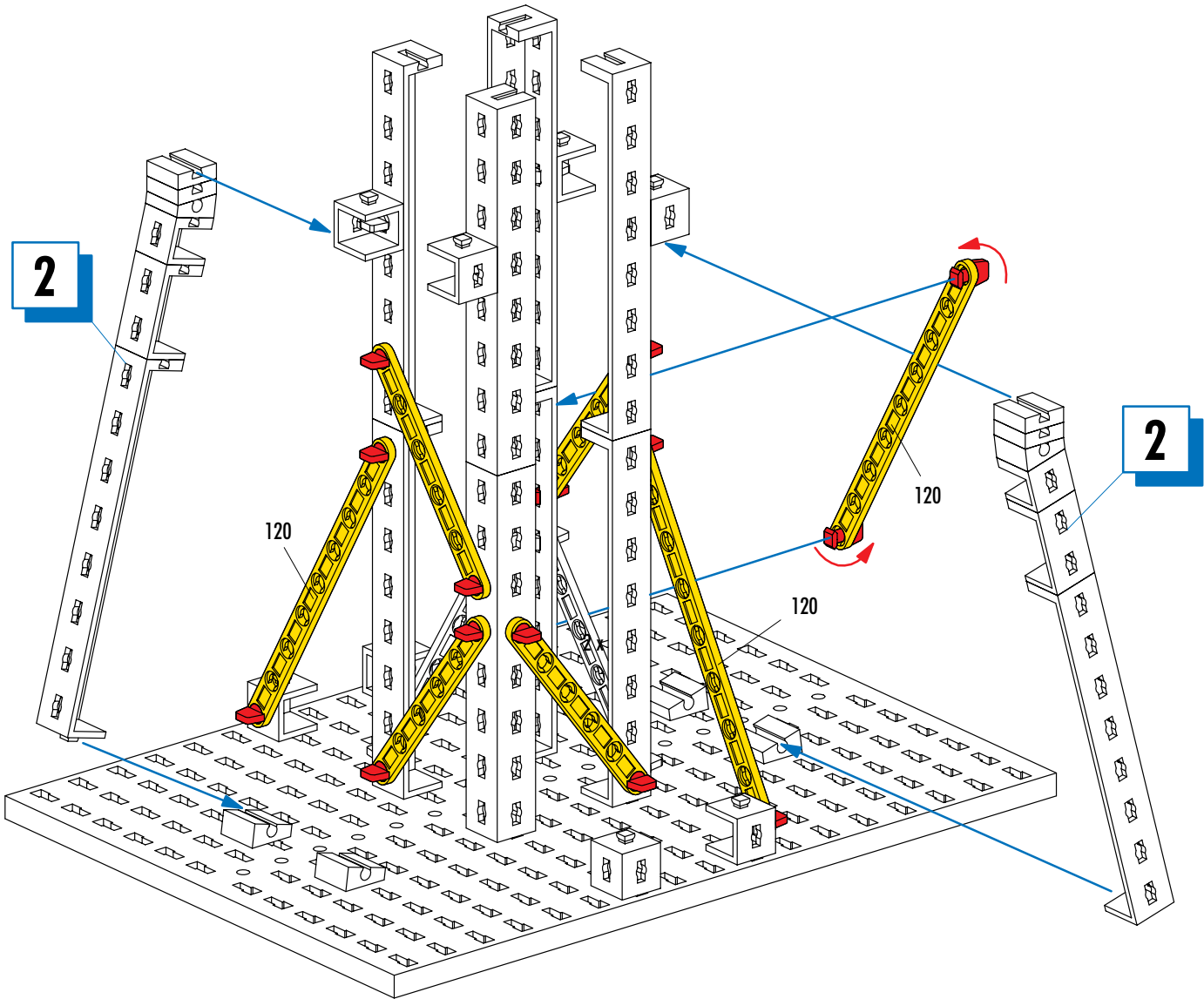

4

2 x 2 x

4 x 15° 2 x 2 x

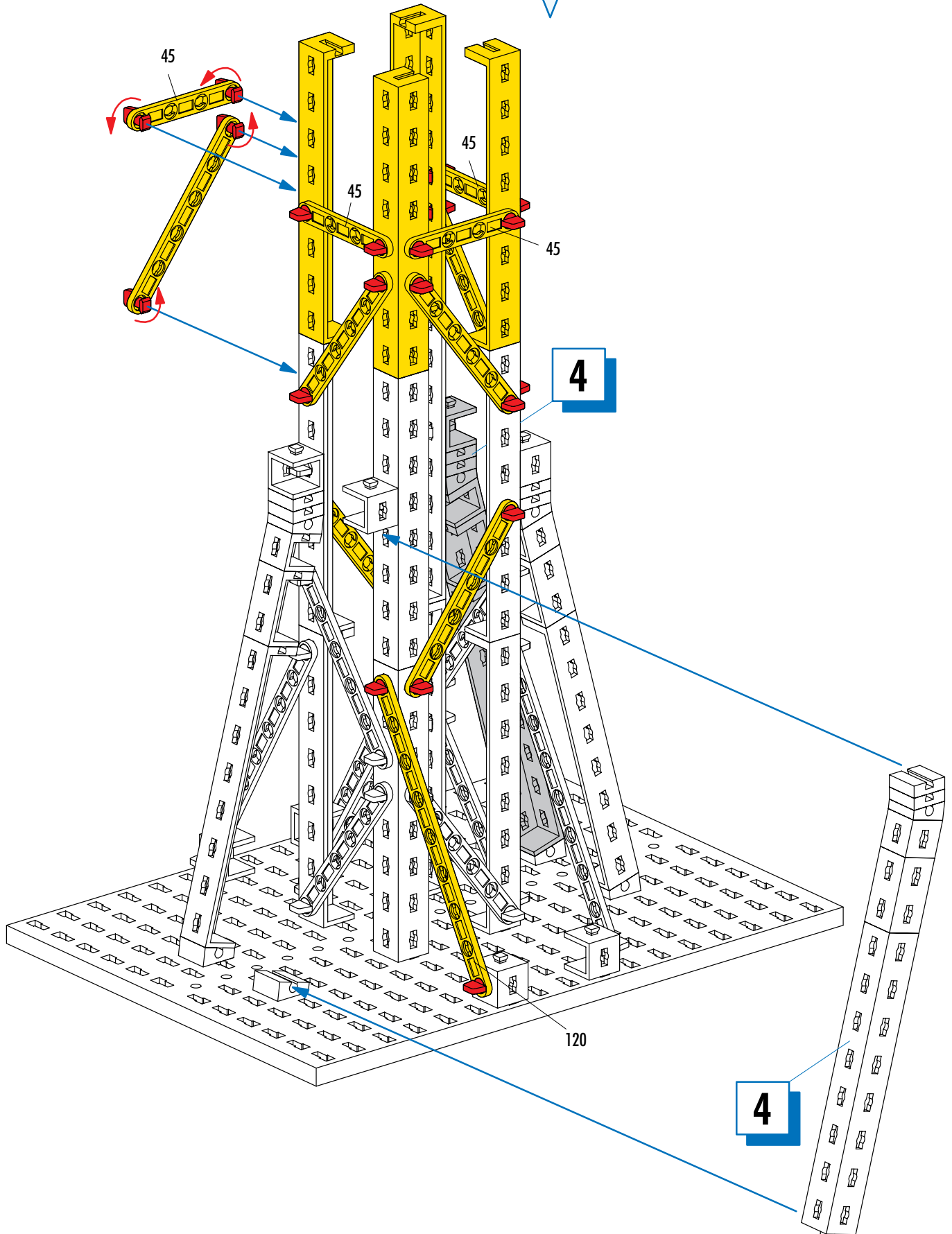
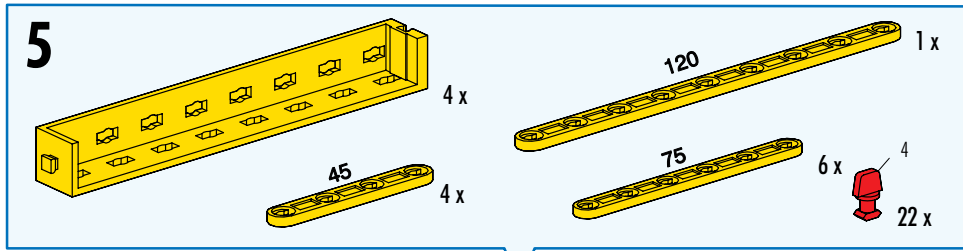

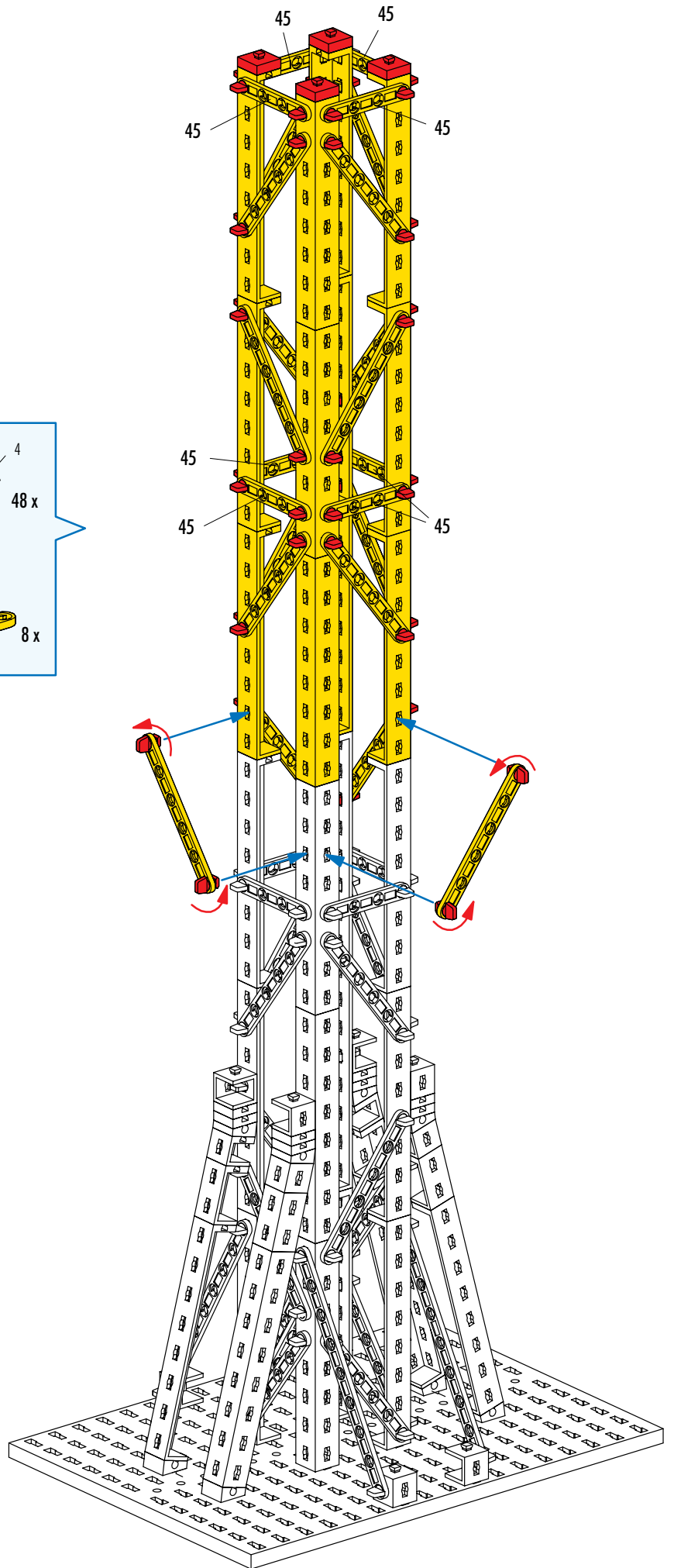
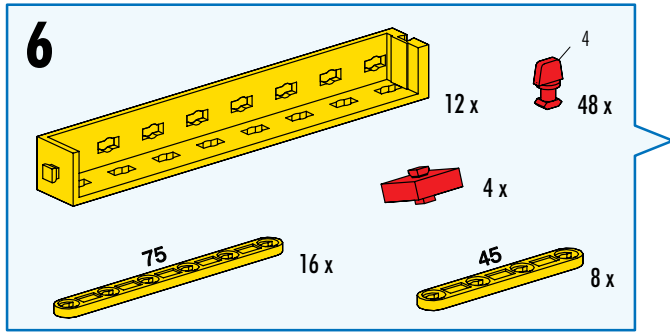

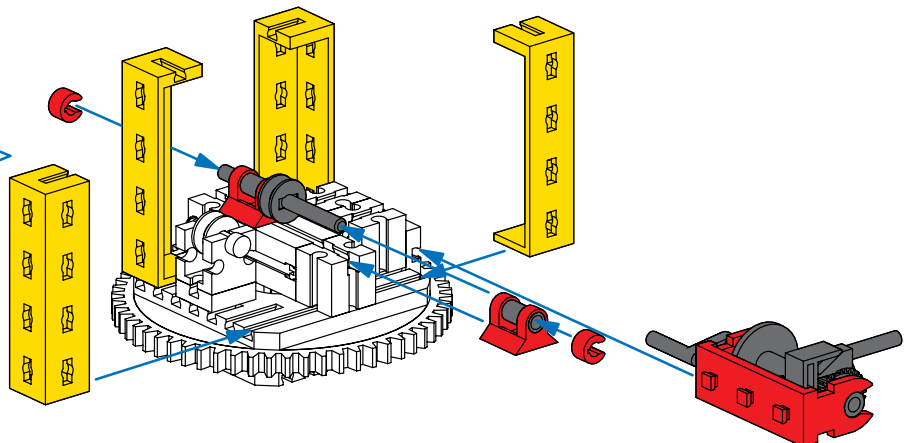
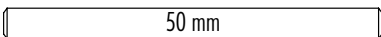
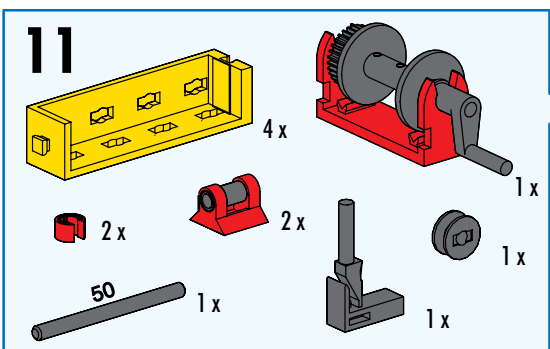
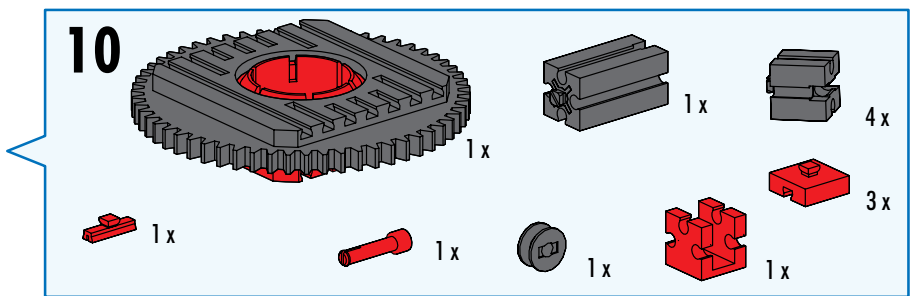
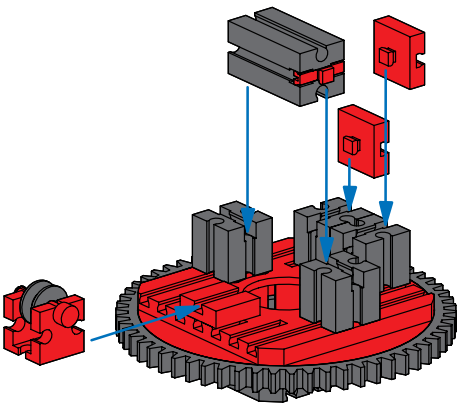
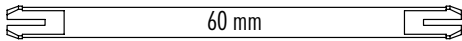
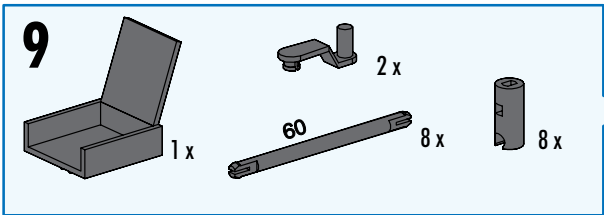
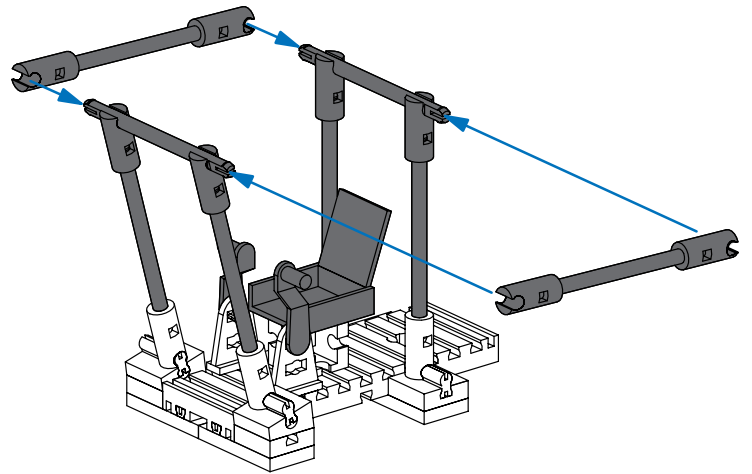
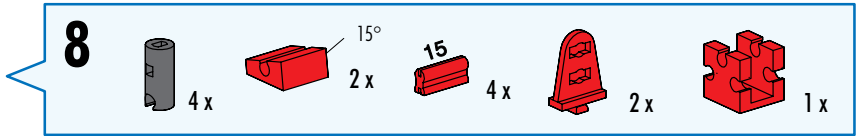
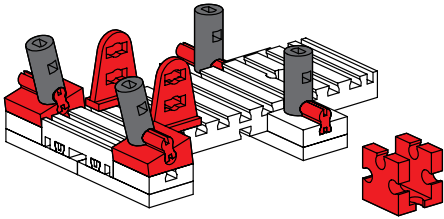
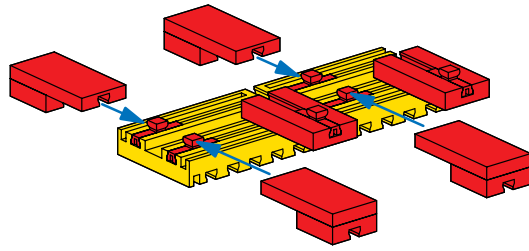
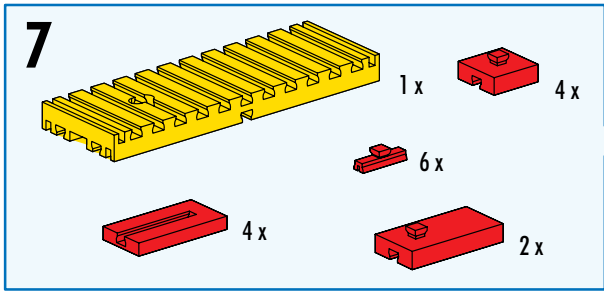

12

- 4 x Yellow Technic Beam 11-hole
- 2 x Red Technic Pin
- 1 x Grey Technic Axle Connector
- 2 x Red Technic Pin with Friction Ridge

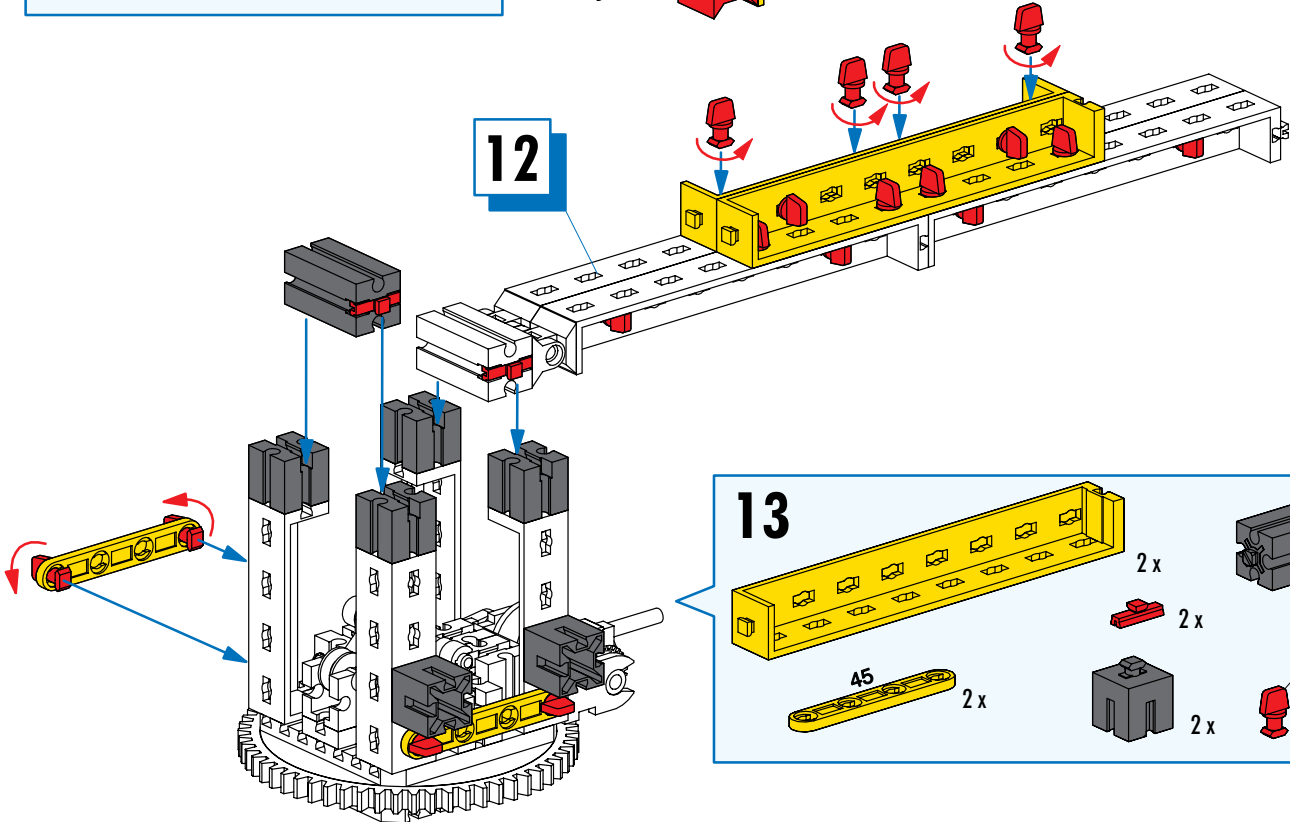
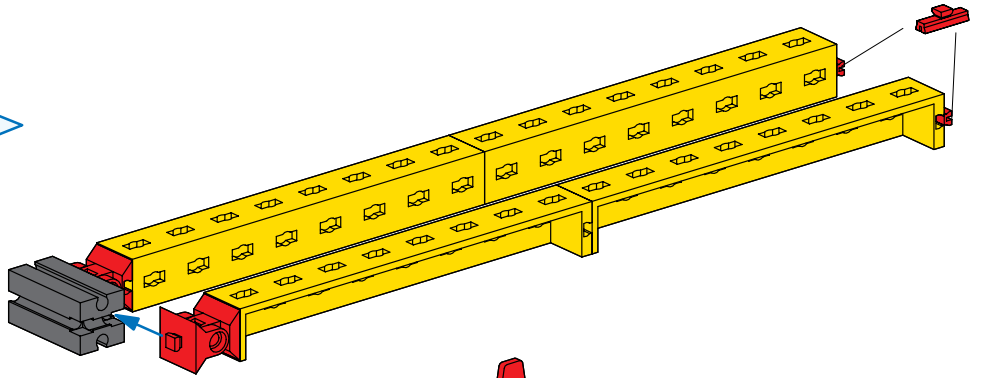

13

- 2 x Yellow Technic Beam 11-hole
- 1 x Grey Technic Axle Connector
- 2 x Red Technic Pin
- 2 x Grey Technic Pin
- 4 x Grey Technic Axle Connector
- 2 x Yellow Technic Beam 45-hole
- 2 x Grey Technic Pin
- 18 x Red Technic Pin

14

- 2 x Yellow Technic Box
- 2 x Grey Technic Axle Connector
- 1 x Red Technic Pin
- 2 x Red Technic Pin
- 2 x Red Technic Pin
- 6 x Red Technic Pin
- 1 x Red Technic Pin
- 1 x Red Technic Pin
- 2 x Red Technic Pin
- 2 x Yellow Technic Box
- 2 x Red Technic Pin with Friction Ridge

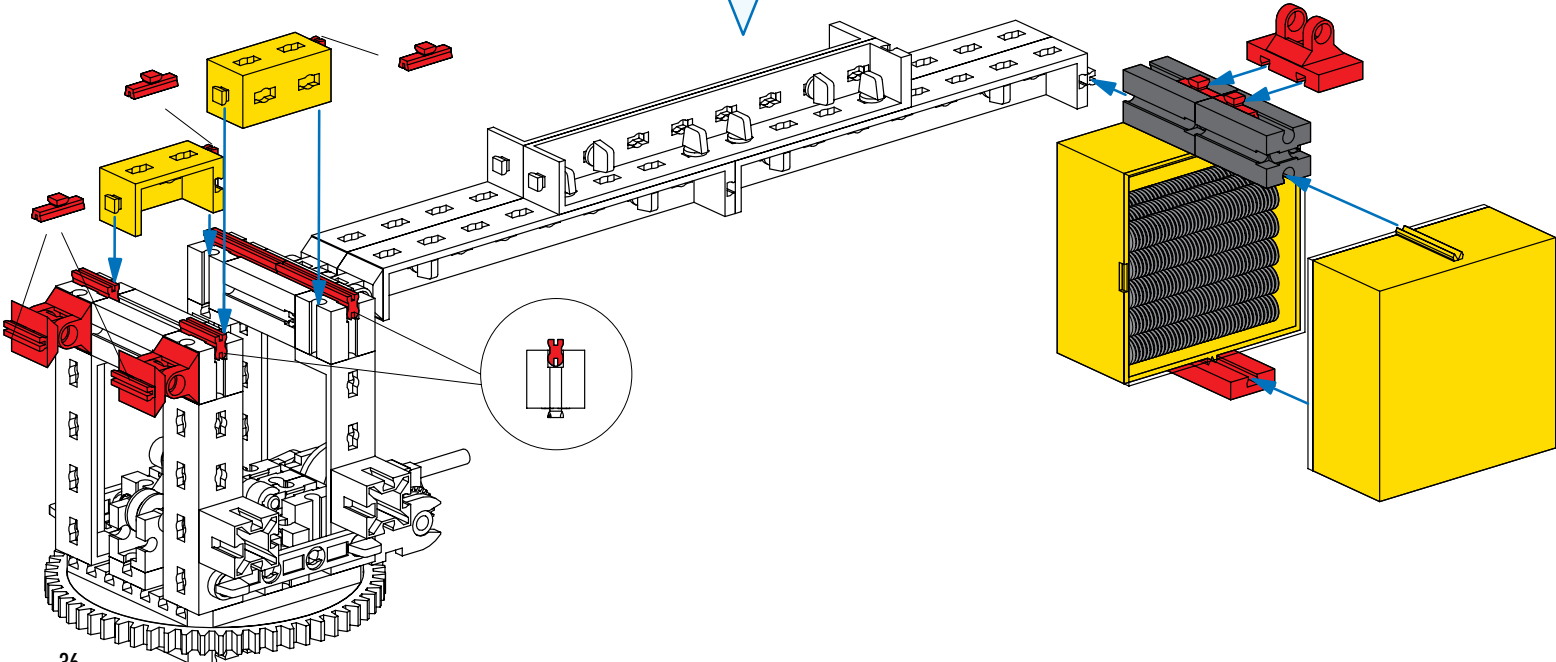

2 x

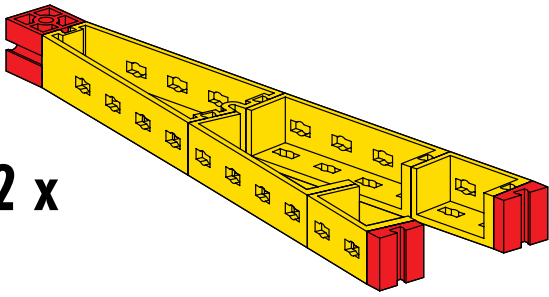

15

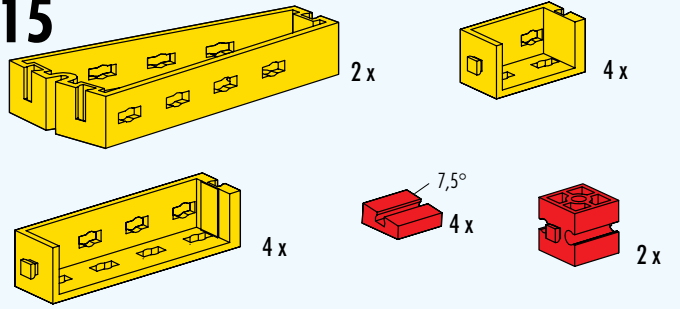

16

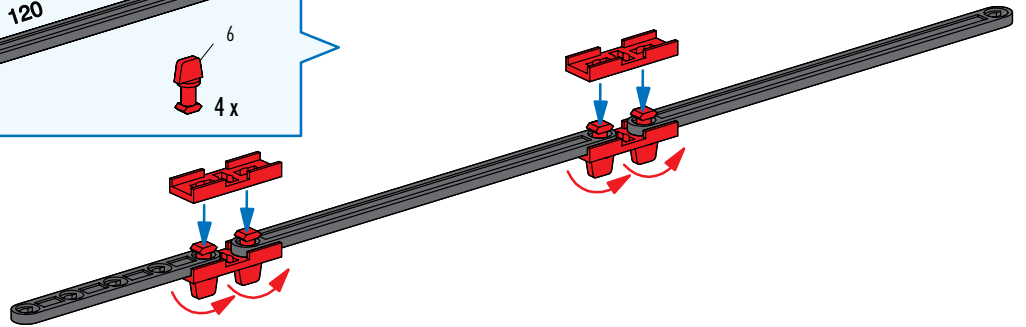
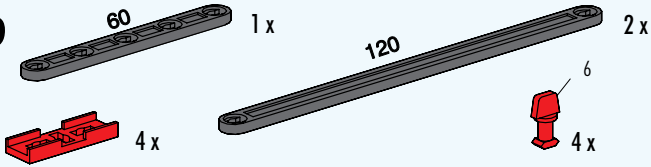

16

17

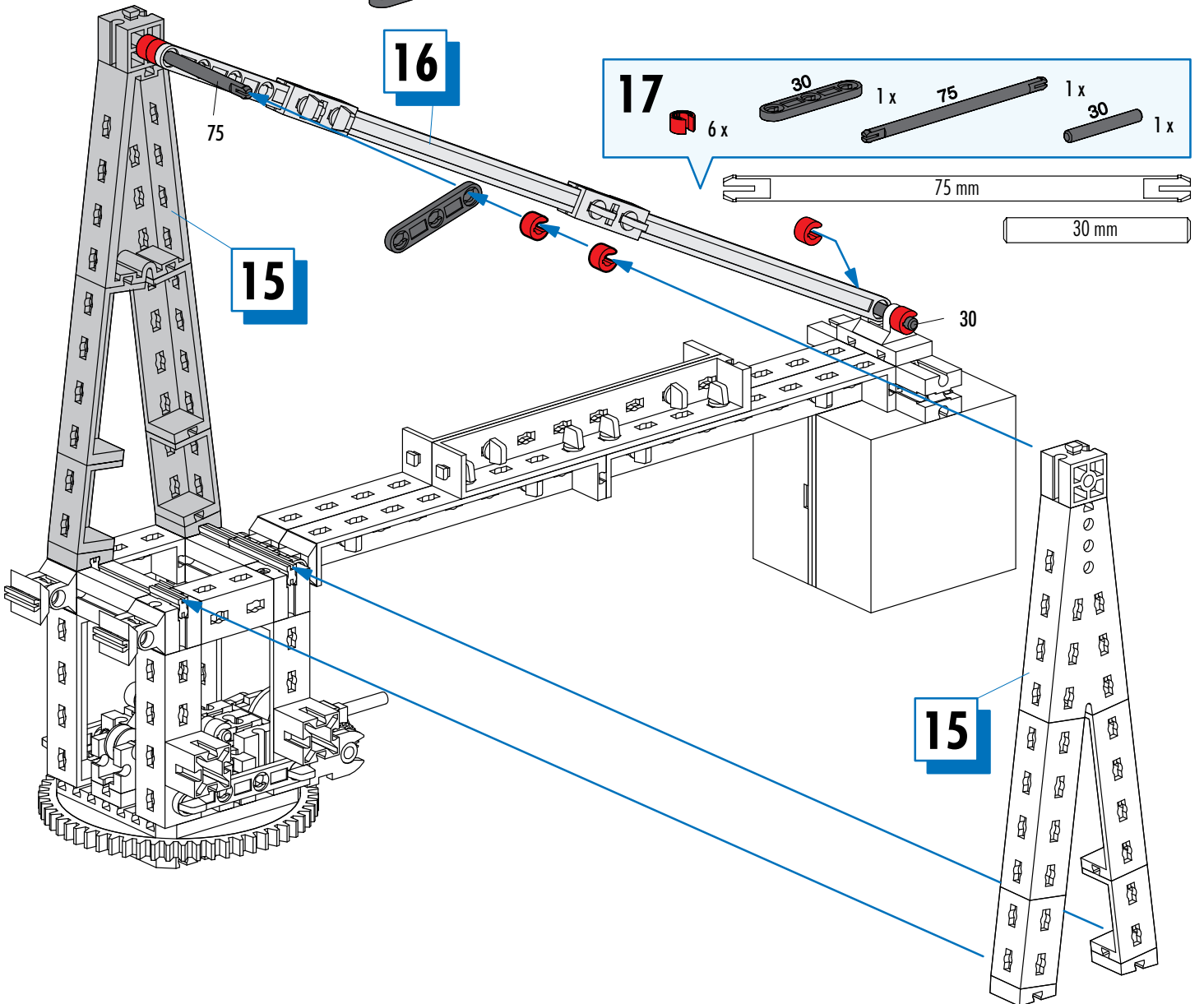
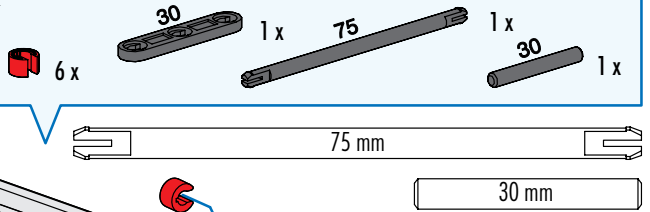

15

15

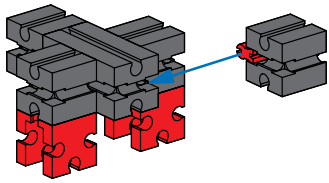

18

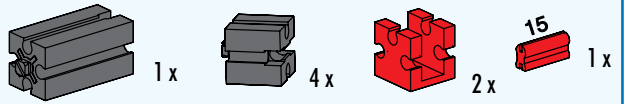

19

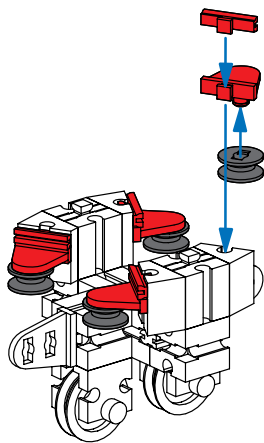
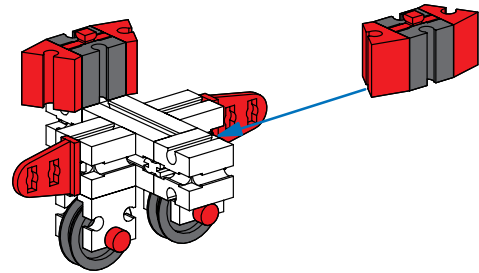
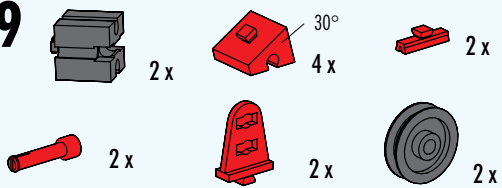

20

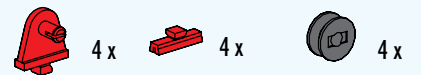

21

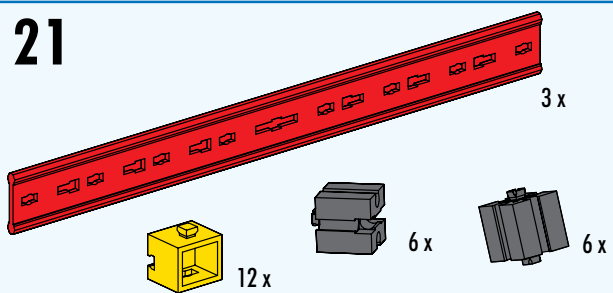

3 x

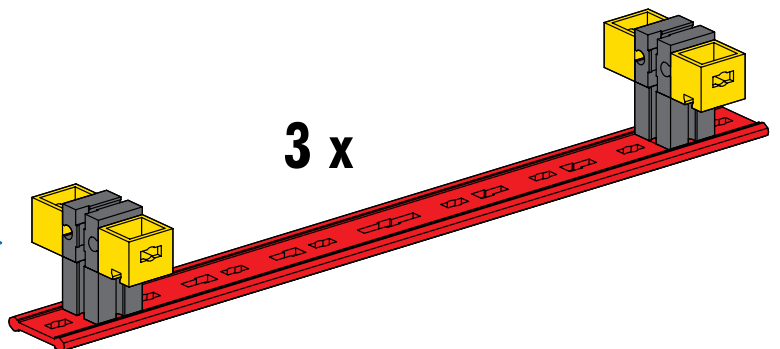

22

- 2 x
- 15
- 2 x
- 4
- 4 x
- 1 x

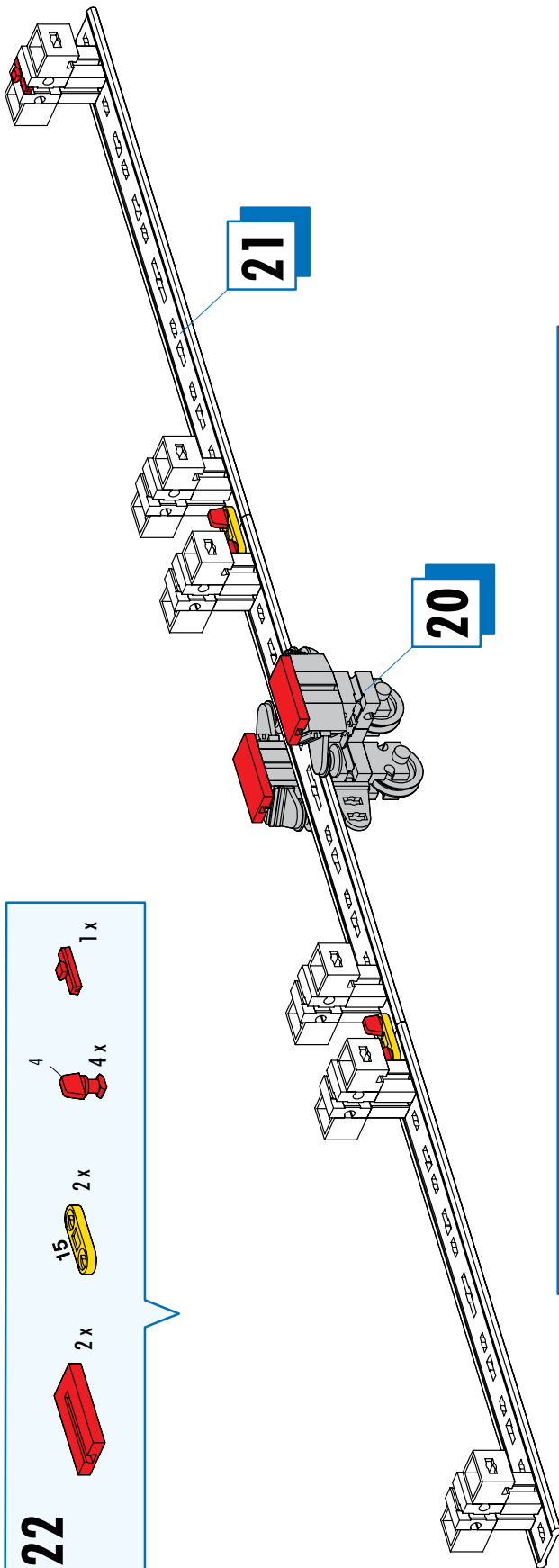

23

- 12 x
- 10 x
- 4
- 60
- 1 x
- 120
- 1 x
- 2 x
- 2 x

60 mm

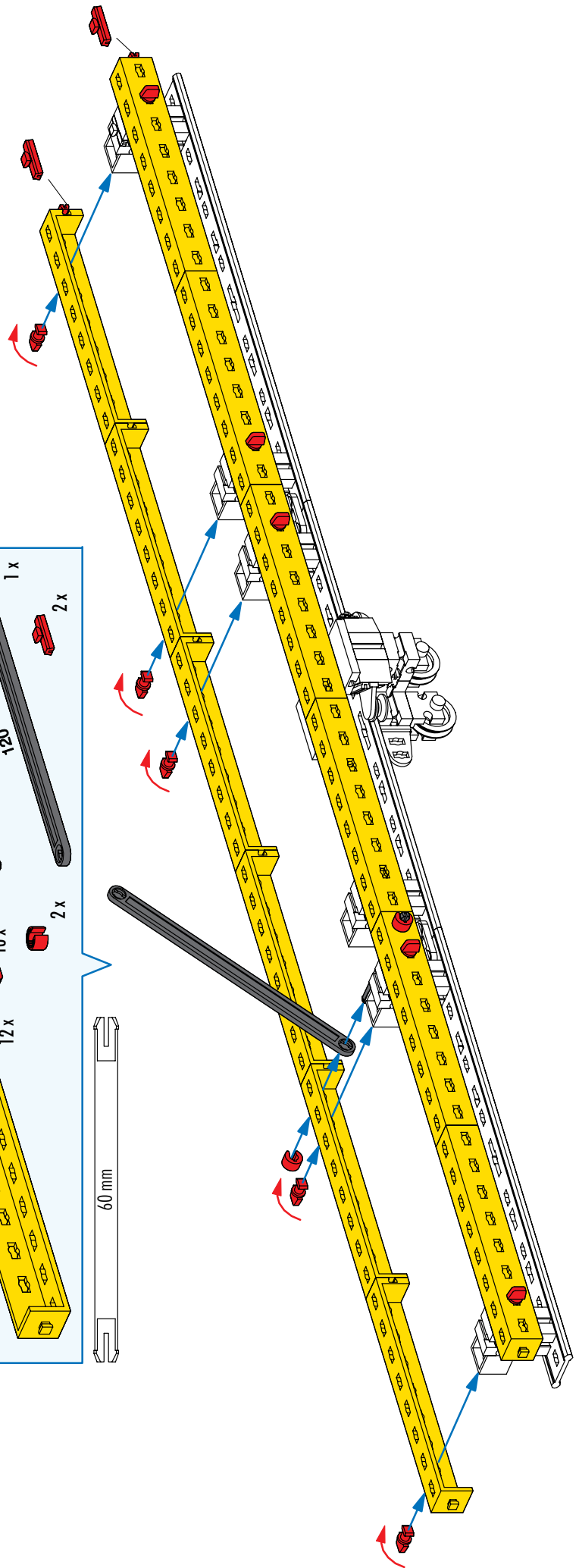

24

- 2 x [Grey Technic Beam 1x3]
- 4 x [Grey Technic Pin Long]
- 8 x [Red Technic Pin Short]
- 2 x [Red Technic Connector]

25

- 1 x [Grey Technic Beam 1x3]
- 1 x [Grey Technic Pin Long]
- 3 x [Grey Technic Pin Long]
- 6 x [Red Technic Pin Short]
- 1 x [Grey Technic Connector]
- 1 x [Grey Technic Pin Long]
- 30 mm [Grey Technic Pin Long]

24

26

- 1 x [Red Technic Connector]
- 2 x [Grey Technic Beam 1x3]
- 1 x [Red Technic Pin Short]
- 1 x [Red Technic Pin Long]
- 1 x [Red Technic Connector]
- 1 x [Red Technic Connector]
- 1 x [Red Technic Connector]
- 1 x [Grey Technic Pin Long]
- 1 x [Grey Technic Pin Long]
- 1 x [Grey Technic Pin Long]
- 75 [Grey Technic Pin Long]

27

- 2 x [Red Technic Pin Long]
- 2 x [Red Technic Connector]
- 2 x [Grey Technic Pin Long]
- 1 x [Red Technic Pin Long]
- 18 x [Red Technic Pin Short]
- 9 x [Yellow Technic Pin Long]

26

25

28

- 45 32 x
- 4 62 x
- 6 2 x
- 1 x

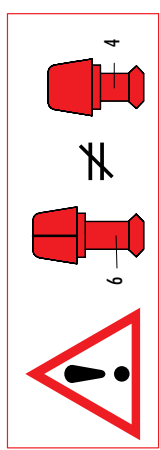
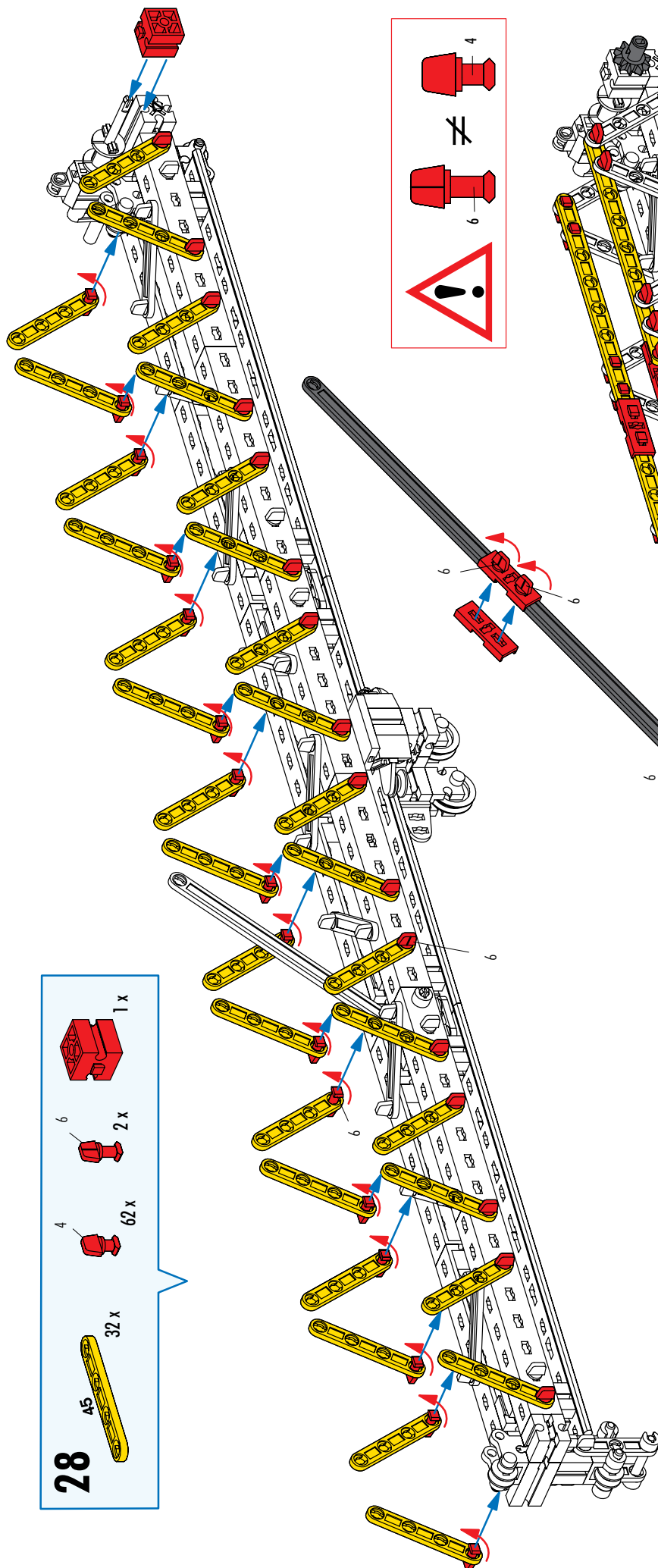

29

- 10 x
- 120
- 120
- 2 x
- 12 x
- 1 x
- 40 x
- 4
- 6
- 8 x

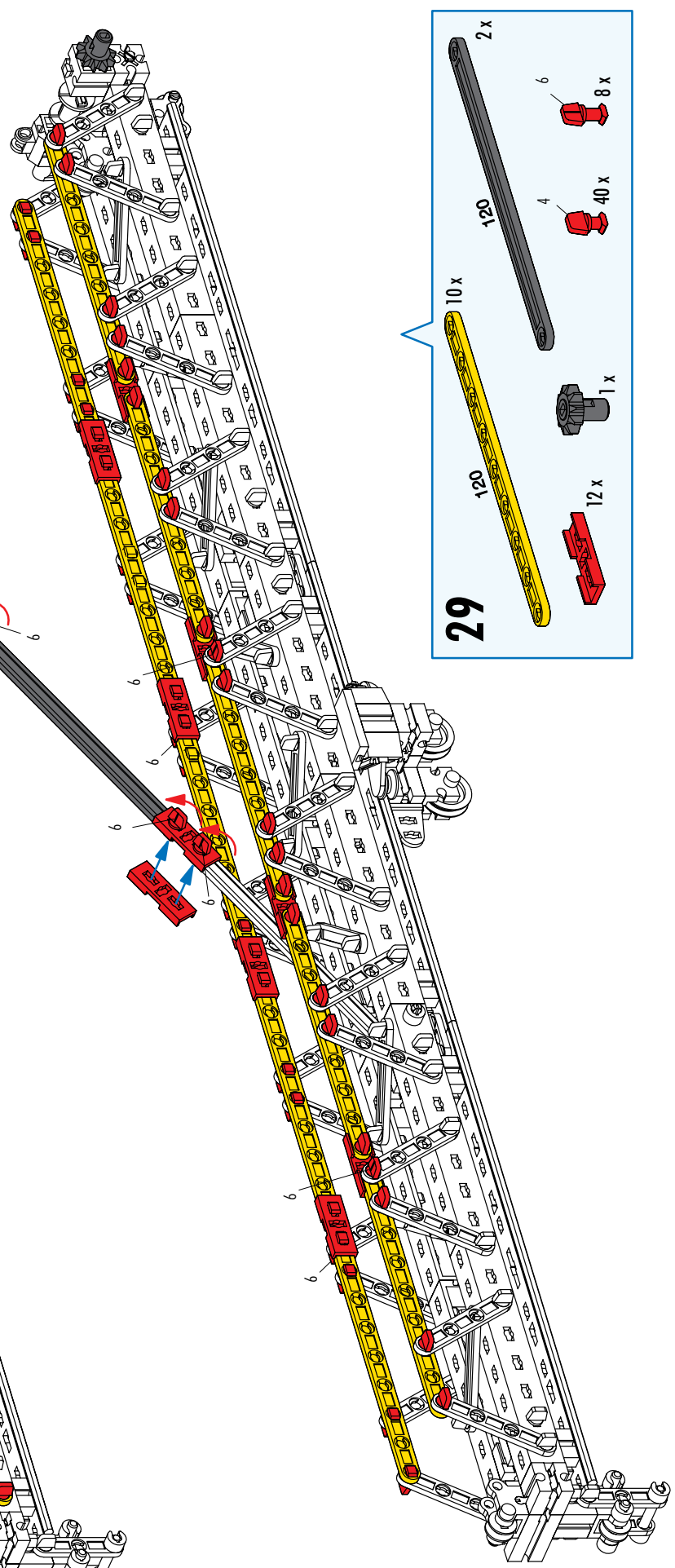

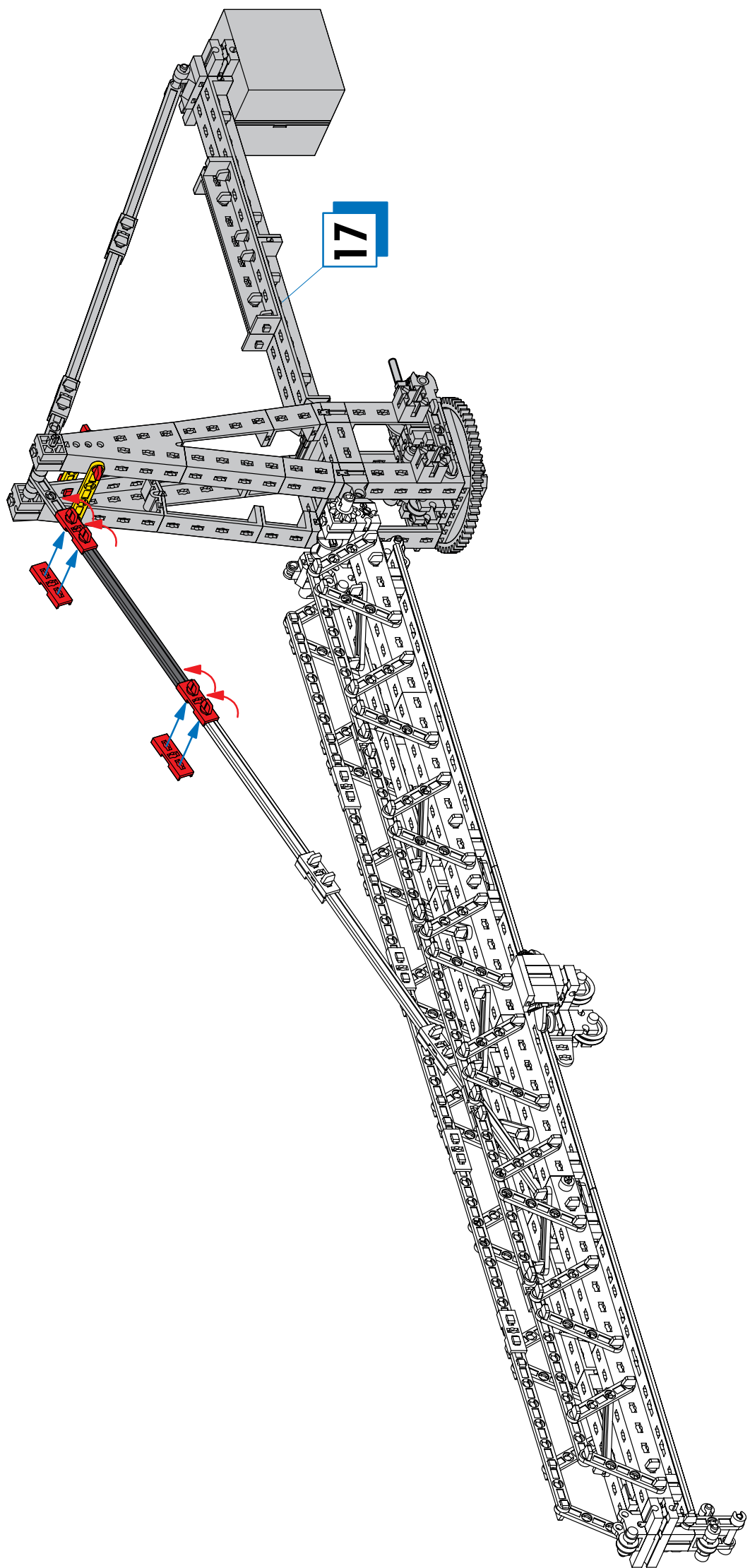
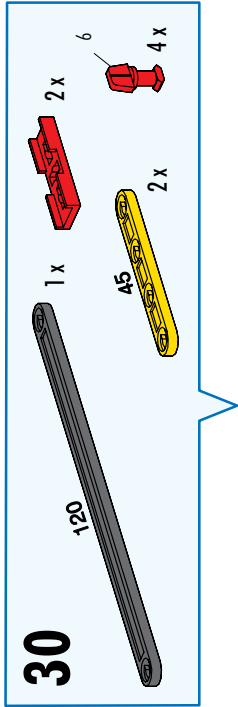

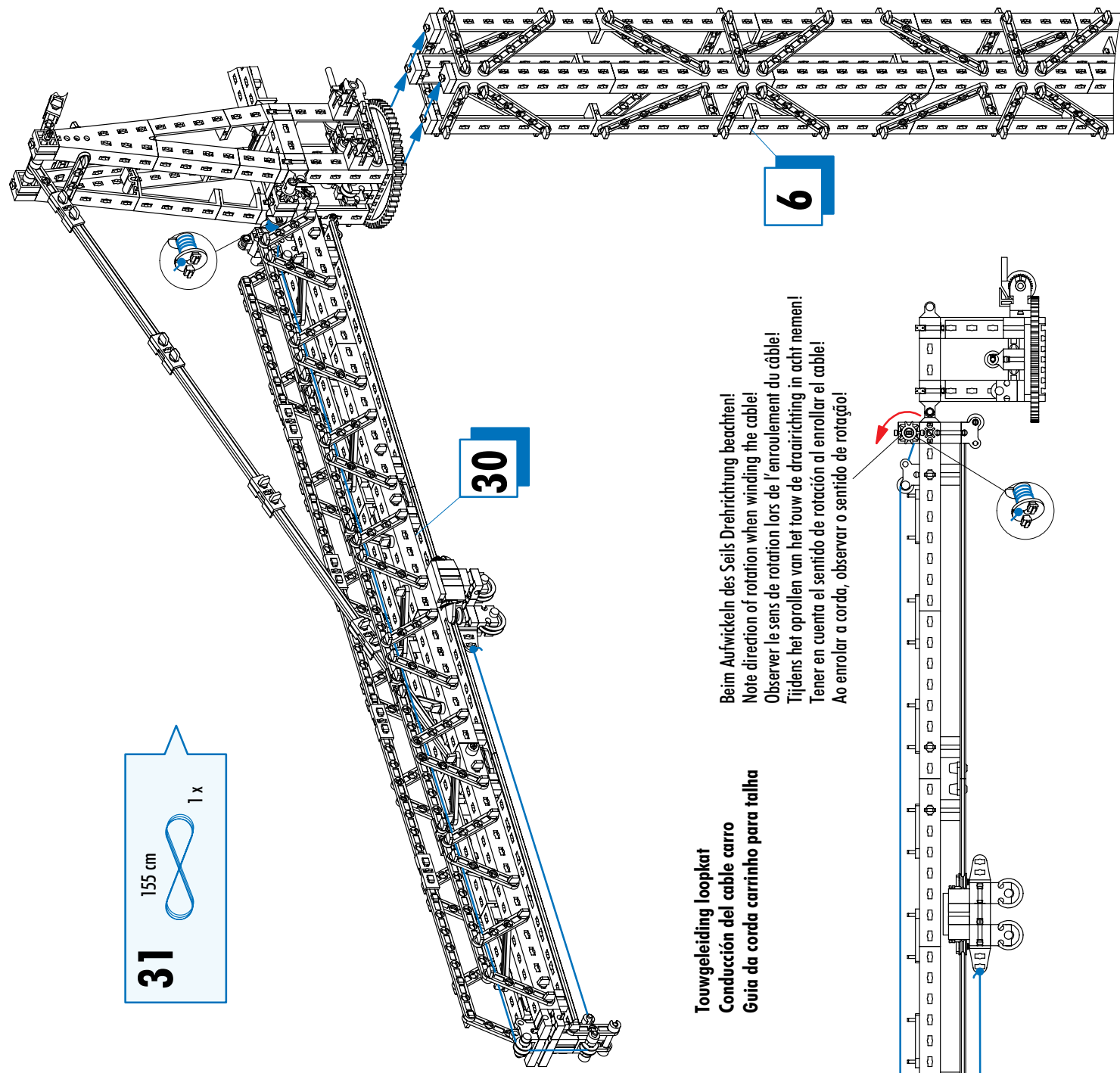

Seilführung Laufkatze
Cable guide crab
Guidage par câbles chariot de pont roulant

Touwgeleiding loopkat
Conducción del cable carro
Guia da corda carrinho para talha

Beim Aufwickeln des Seils Drehrichtung beachten!
 Note direction of rotation when winding the cable!
 Observer le sens de rotation lors de l'enroulement du câble!
 Tijdens het oprollen van het touw de draairichting in acht nemen!
 Tener en cuenta el sentido de rotación al enrollar el cable!
 Ao enrolar a corda, observar o sentido de rotação!

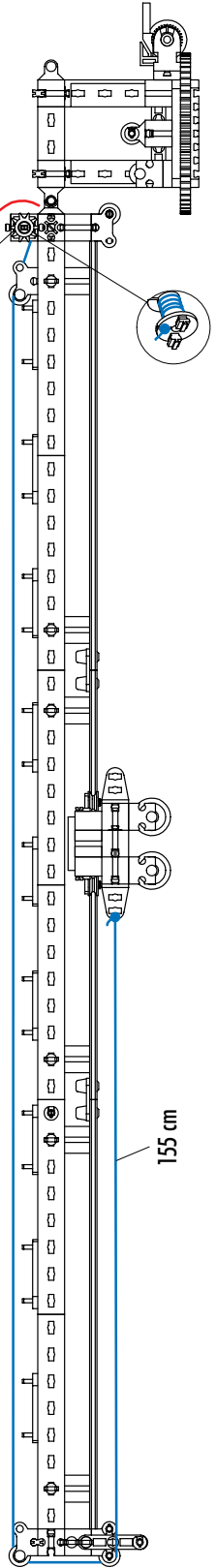

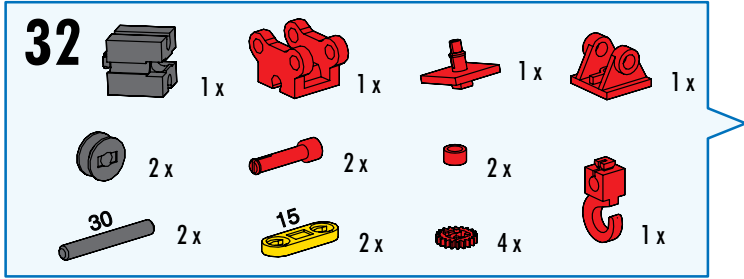

30 mm

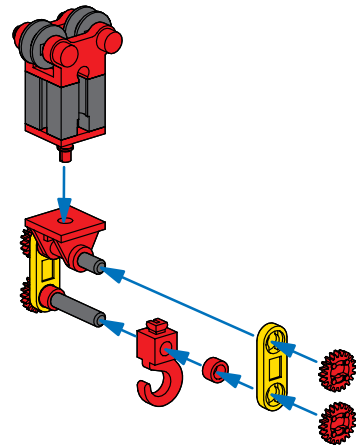

Zahnrad erst nach Spannen des Seils aufstecken
 Do not fit the gear wheel until the cable has been tightened
 Tendre d'abord le câble avant d'emboîter la roue dentée
 Het tandwiel pas na het opspannen van het touw aanbrengen
 Encajar la rueda dentada después de tensar el cable
 Esticar a corda antes de montar a roda dentada

Seilführung siehe Seite 45
 Cable guide see page 45
 Guidage par câbles voir page 45
 Zie voor de touwgeleiding pagina 45
 Conducción del cable ver página 45
 Guia da corda, ver página 45

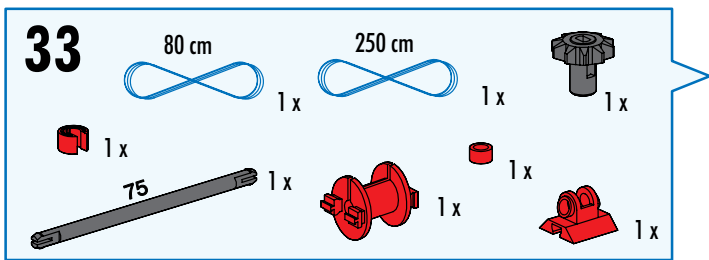
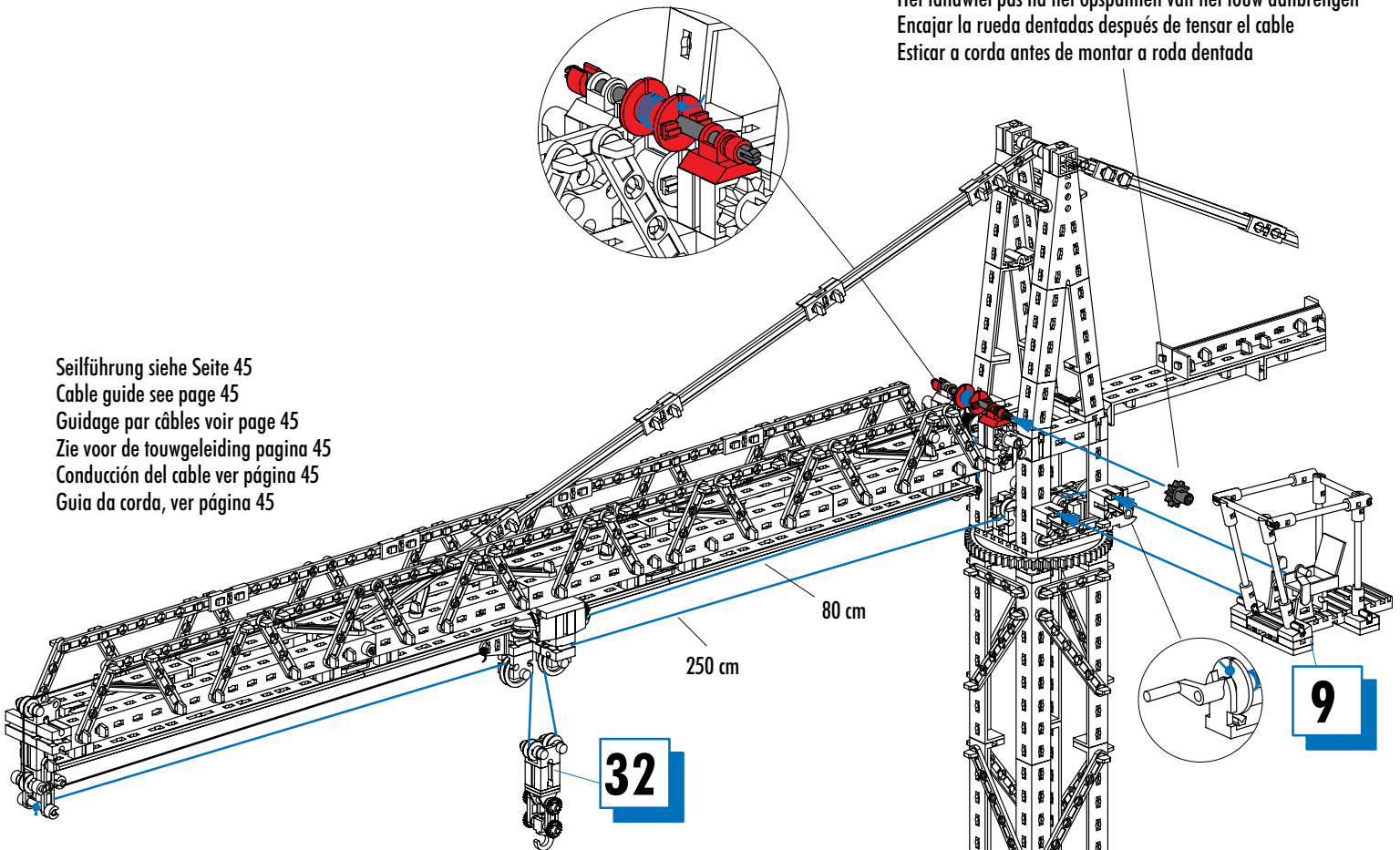

75 mm

Seilführung Laufkatze
Cable guide crab
Guidage par câbles chariot de pont roulant

Touwgeleiding loopkat
Conducción del cable carro
Guia da corda carrinho para talha

Seil spannen und Zahnrad aufstecken
 Tighten cable and fit gear wheel
 Tendre le câble et emboîter la roue dentée
 Het touw opspannen en het tandwiel aanbrengen
 Tensar el cable y encajar la rueda dentada
 Esticar acorda e montar a roda dentada

Beim Aufwickeln des Seils Drehrichtung beachten!
 Note direction of rotation when winding the cable!
 Observer le sens de rotation lors de l'enroulement du câble!
 Tijdens het oprollen van het touw de draairichting in acht nemen!
 Tener en cuenta el sentido de rotación al enrollar el cable!
 Ao enrolar a corda, observar o sentido de rotação!

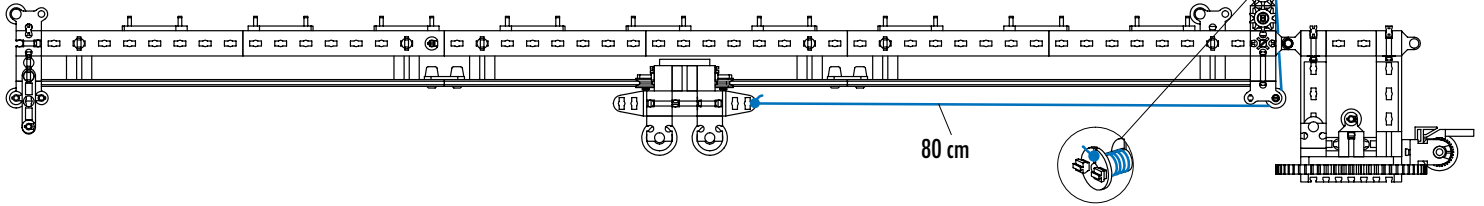

Seilführung Kranhaken
Cable guide crane hook
Guidage par câbles crochet

Touwgeleiding kraanhaak
Conducción del cable gancho de grúa
Guia da corda gancho da grua

Seil festknuten
 Knot cable firmly
 Fixer le câble par un noeud
 Het touw vastknopen
 Anudar fijamente el cable
 Fixar corda mediante nó

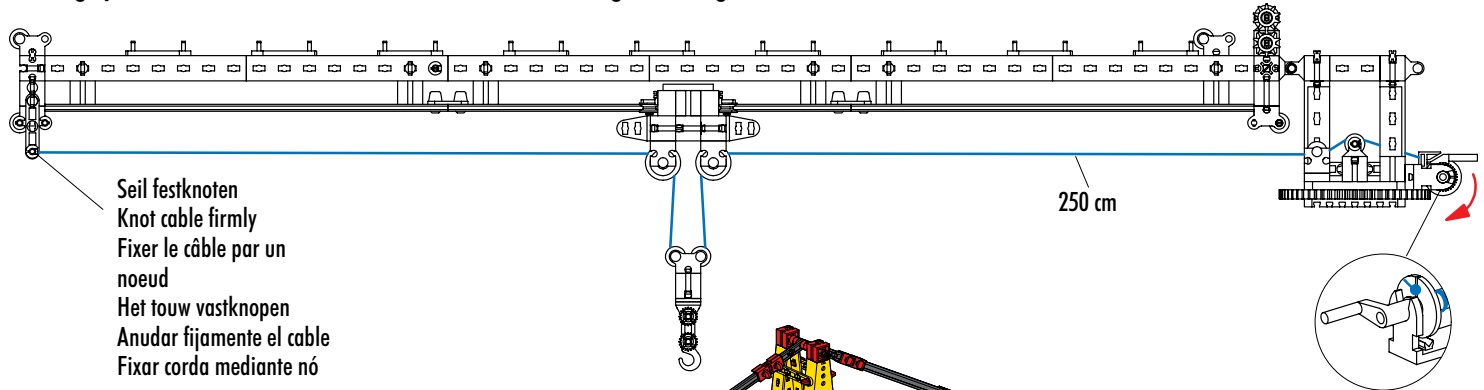

Motorisierung und Fernsteuerung
Motorization and remote control
Motorisation et télécommande

Kranhaken
Crane hook
Crochet

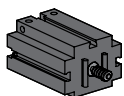

Kraanhaak
Gancho de grúa
Gancho da grua

Motorisering en afstandsbesturing
Motorización y mando a distancia
Motorização e telecomando

Mini Motor
Set
30342

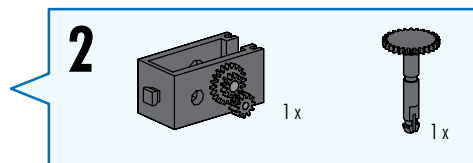
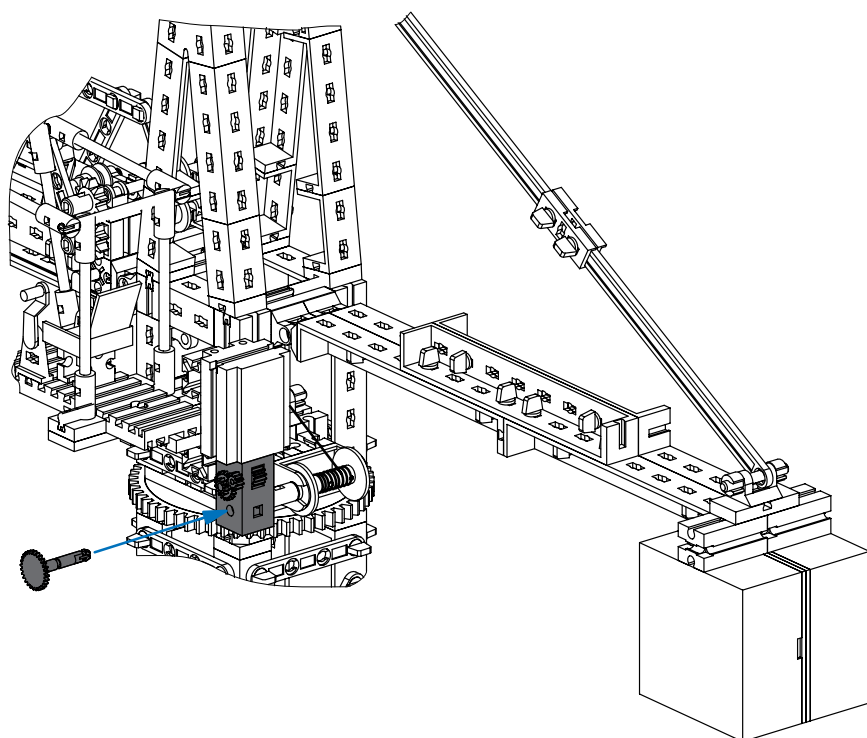
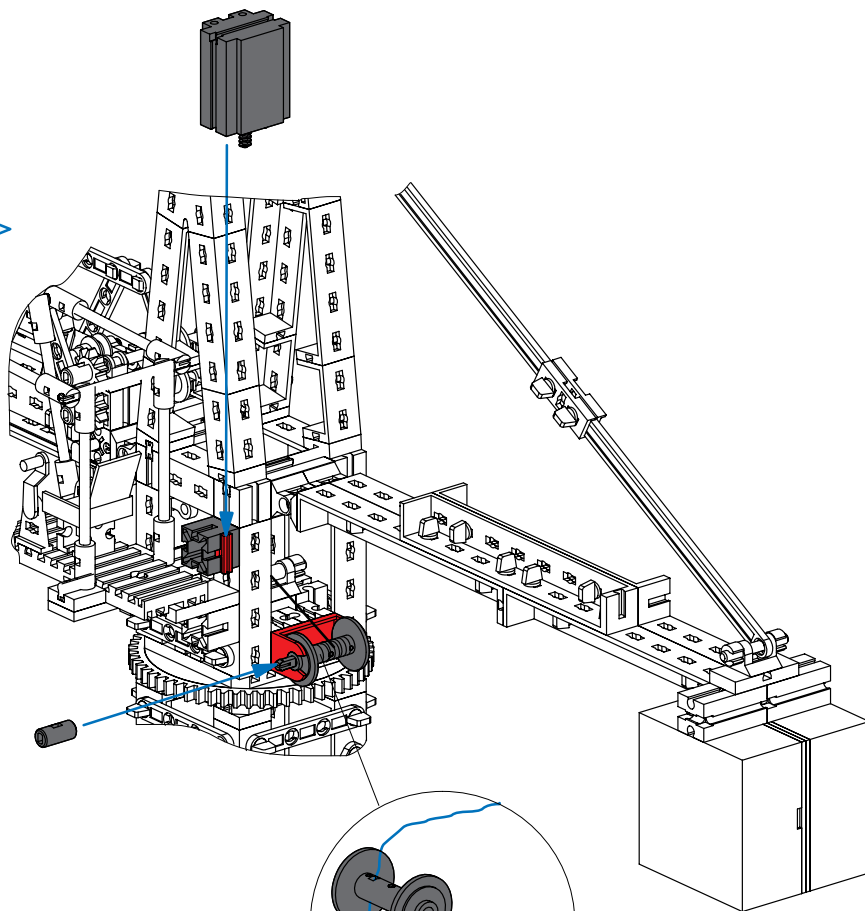
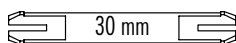
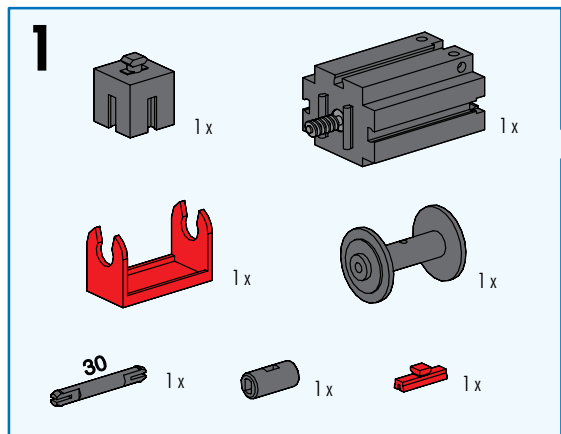

Drehkranz
Slewing ring
Couronne d'orientation

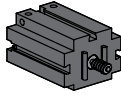

Schamelstel
Corona giratoria
Coroa rotativa

Mini Motor
Set
30342

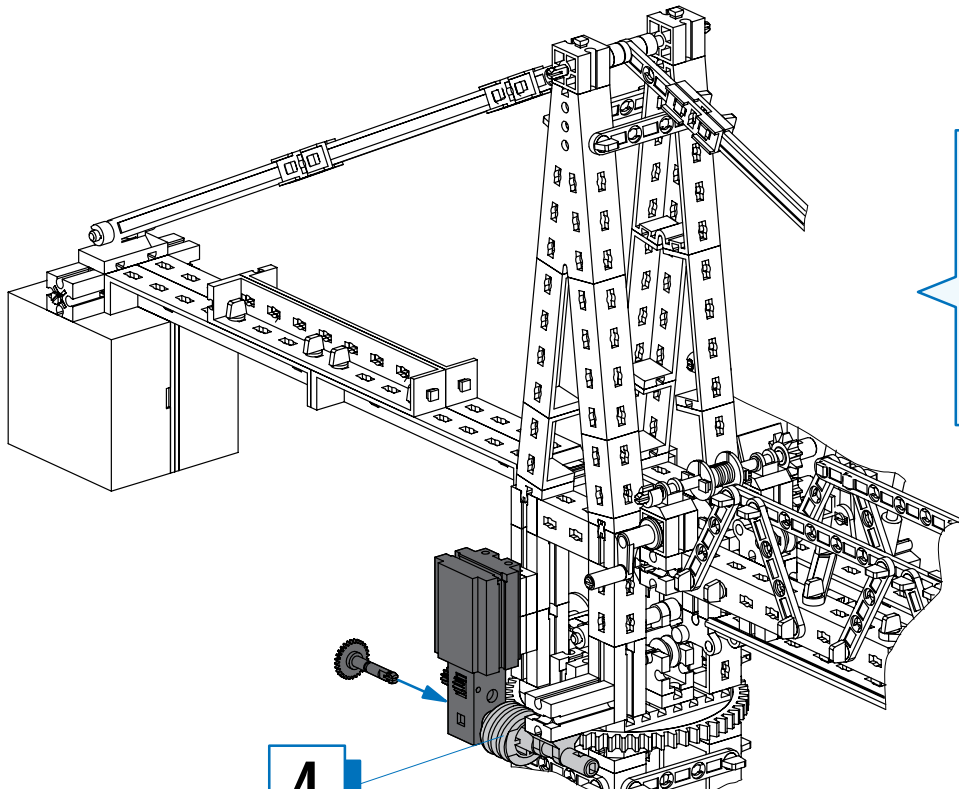
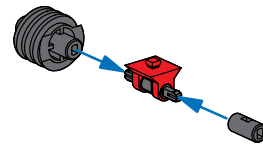
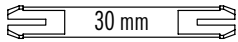
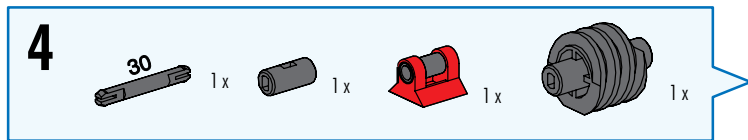
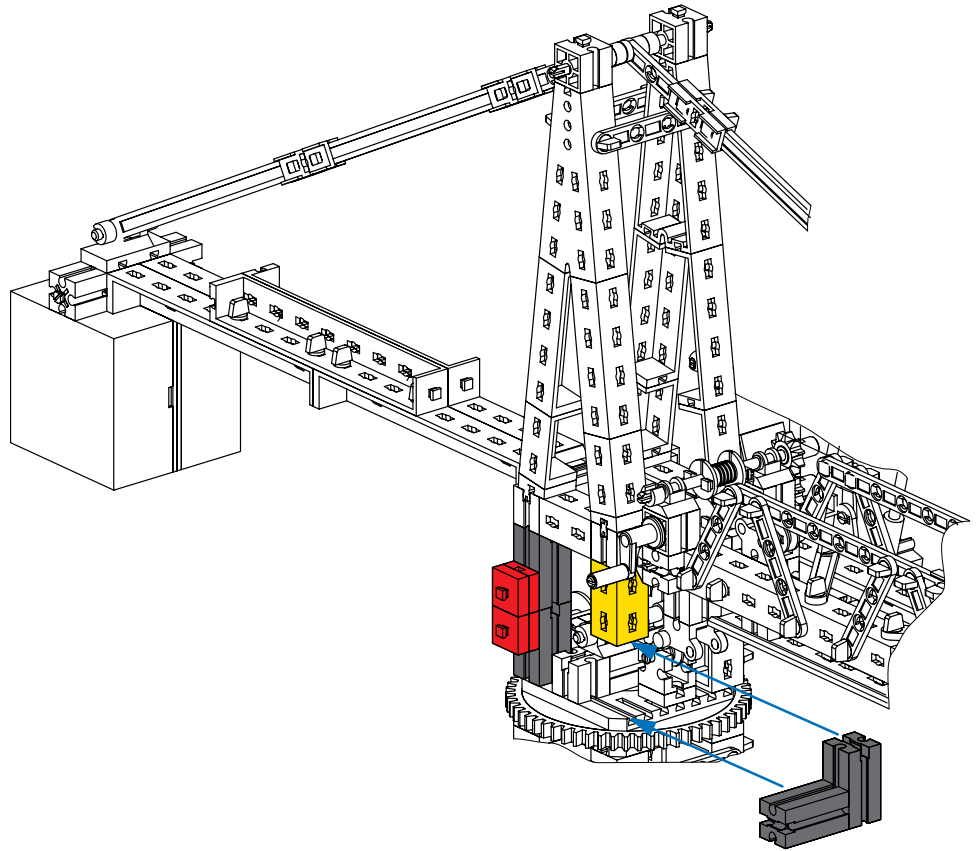
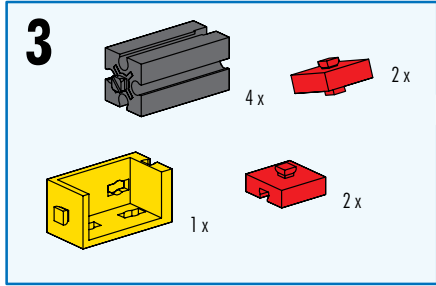

4

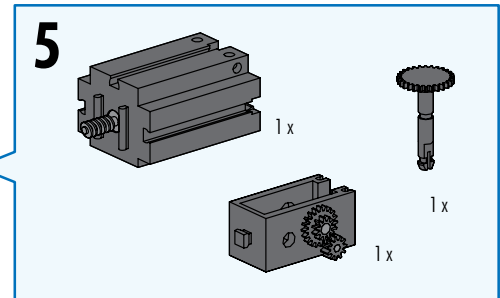

Laufkatze
Crab
Chariot de pont roulant

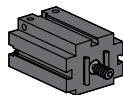

Loopkat
Carro
Carrinho para talha

Mini Motor
Set
30342

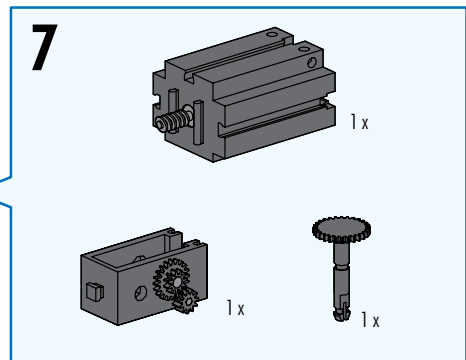
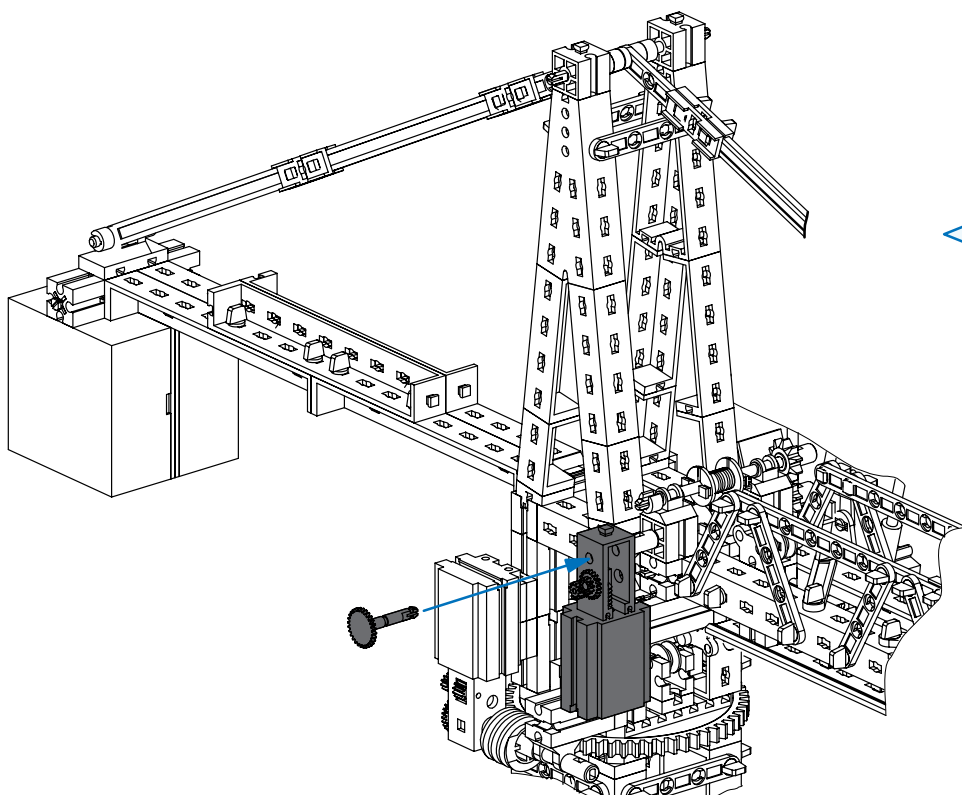
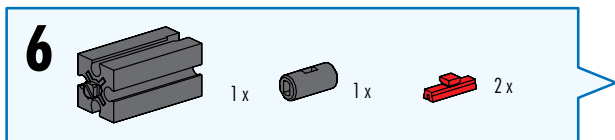
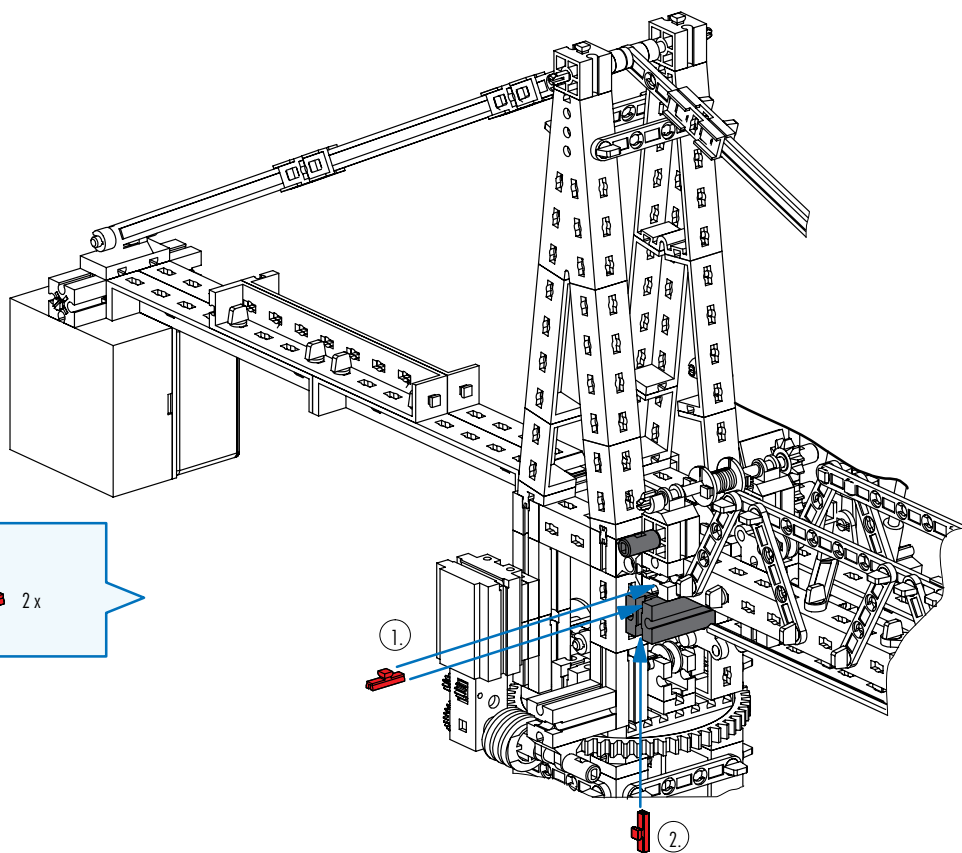
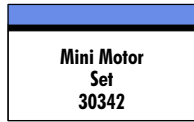

Fernsteuerung
Remote control
Télécommande

Afstandsbesturing
Mando a distancia
Telecomando

IR Control
Set
30344

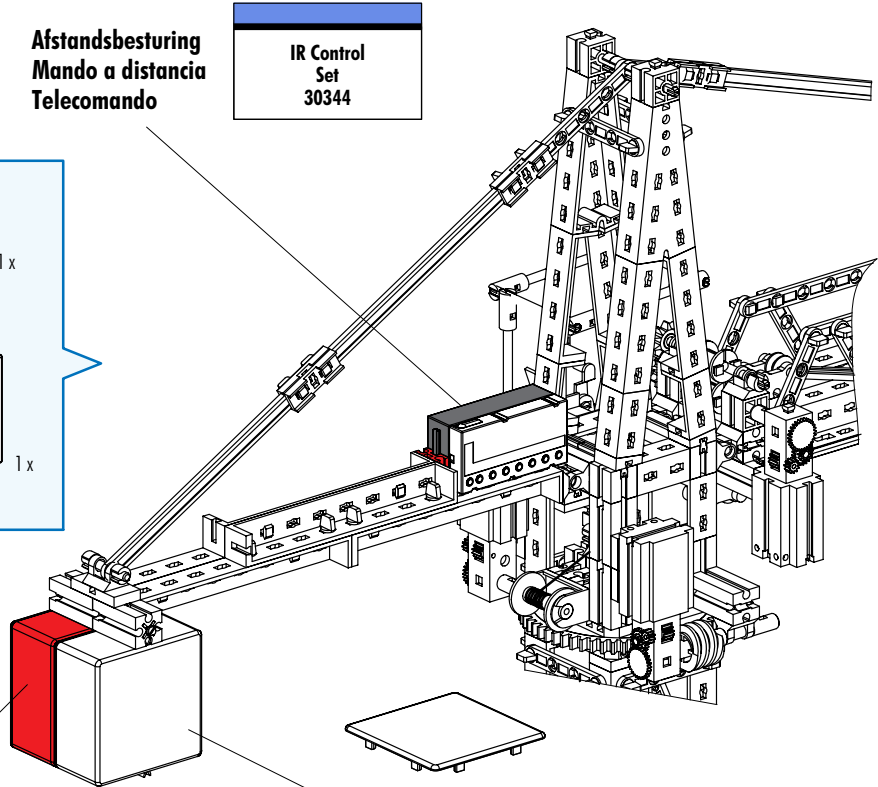
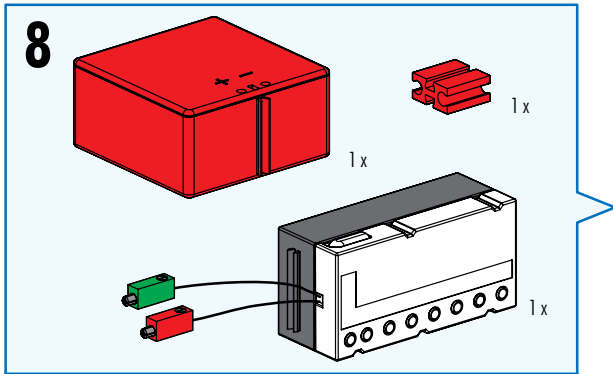

Stromversorgung
Power supply
Alimentation électrique

Stroomvoorziening
Alimentación de corriente
Alimentação elétrica

Accu
Set
34969

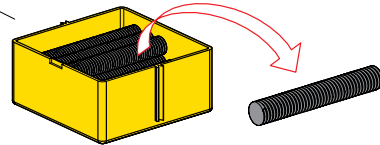

4 Stück entnehmen
Take 4 pieces
Prélever 4 pièces
4 stuks uitnemen
Sacar 4 unidades
Retirar 4 peças

Schaltplan
Circuit diagram
Plan électrique

Schakelschema
Diagrama de circuitos
Plano elétrico de ligação

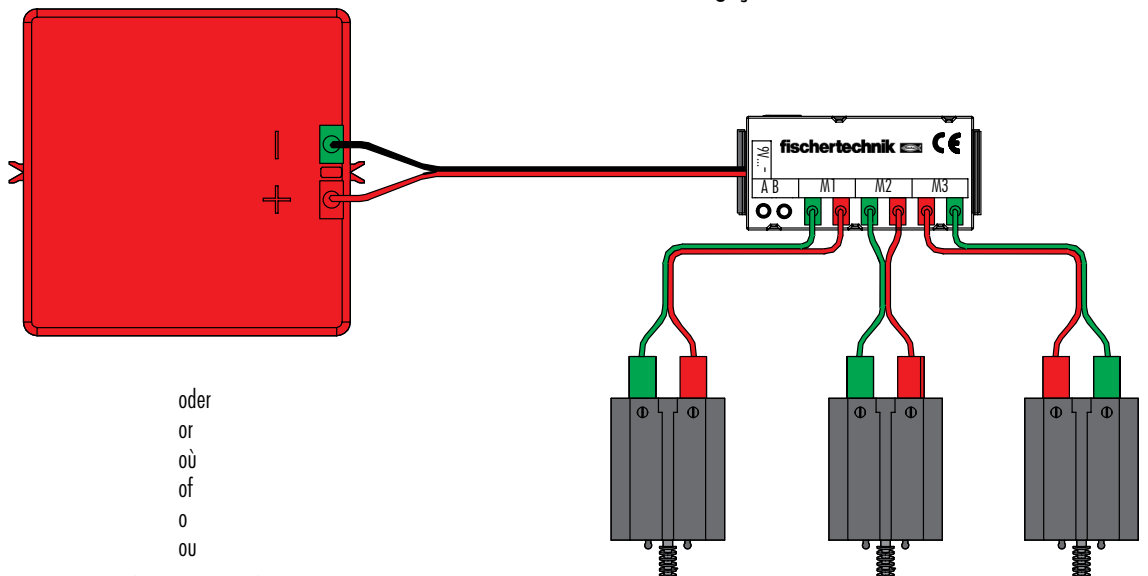

oder
or
ou
of
o
ou

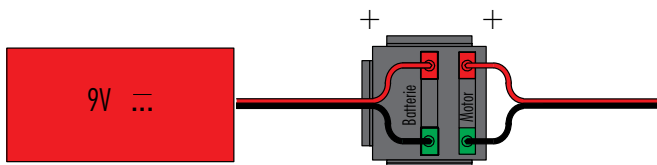

Kranhaken
Crane hook
Crochet
Kraanhaak
Gancho de grúa
Gancho da grua

Laufkatze
Crab
Chariot de pont roulant
Loopkat
Carro
Carrinho para talha

Drehkranz
Slewing ring
Couronné d'orientation
Schamelstel
Corona giratoria
Coroa rotativa

