

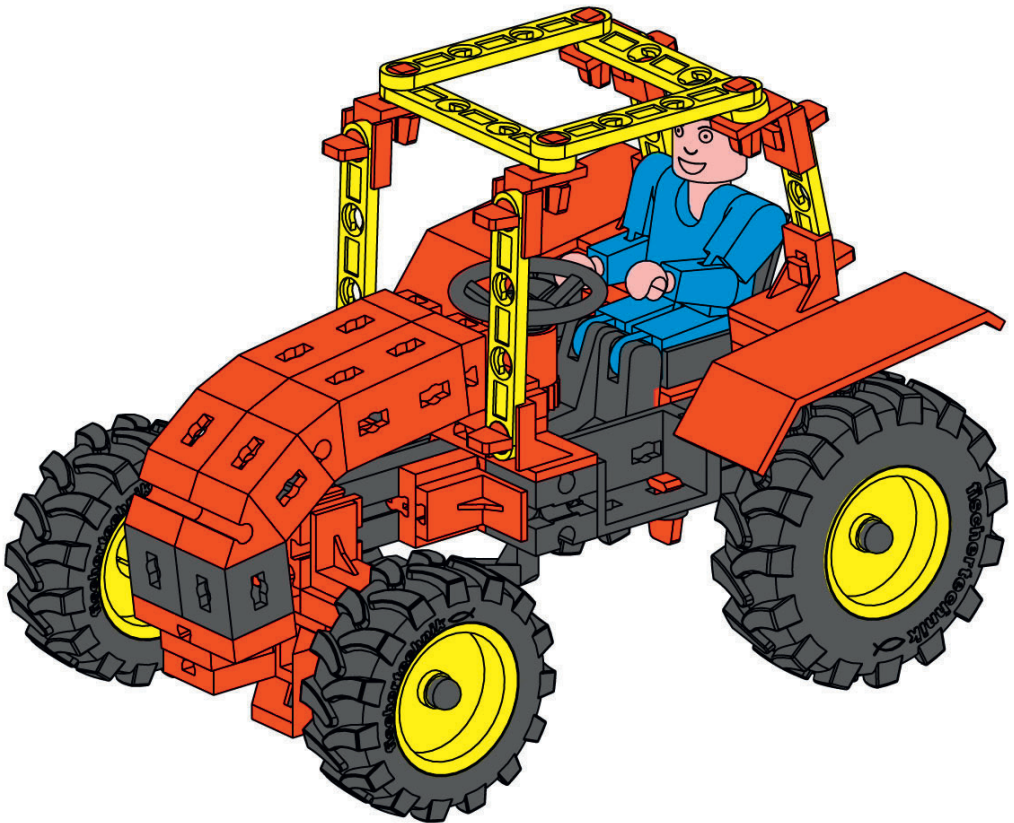











TRACTORS

fischertechnik 

BASIC



	31 010 2 x		31 915 1 x		35 049 3 x
	31 011 2 x		31 916 1 x		35 050 2 x
	31 060 2 x		31 982 6 x		35 067 1 x
	31 061 2 x		32 064 3 x		35 068 2 x
	31 436 1 x		32 071 5 x		35 998 2 x
	31 597 3 x		32 627 4 x		36 323 10 x
	31 670 4 x		32 853 1 x		36 324 4 x
	31 674 4 x				36 334 1 x
	31 766 1 x		32 870 4 x		36 819 1 x
	31 843 2 x		32 879 3 x		36 912 1 x
	31 888 2 x		32 881 3 x		36 913 1 x
	31 894 1 x		32 882 1 x		36 914 1 x

	36 920 2 x		38 423 6 x		106 767 2 x
	36 922 2 x		38 428 3 x		121 661 2 x
	37 237 8 x		38 538 2 x		127 471 2 x
	37 468 6 x		38 541 6 x		127 472 2 x

- Achtung! Verletzungsgefahr an Bauteilen mit funktionsbedingten scharfen Kanten und Spitzen!
- Caution! Be careful not to hurt yourself on components with sharp or pointed edges!
- Attention! Risque de blessure sur les éléments comportant des arêtes et o pointes vives indispensables au bon fonctionnement!
- Let op! U kunt zich bezeren aan bouwstenen met scherpe randen of punten!
- Attenzione! Esiste il pericolo di lesione con i pezzi di costruzione che hanno bordi e punte spigolosi necessari per la funzionalità del pezzo!
- Alle Einzelteile, insbesondere bewegliche Teile sind falls notwendig zu warten und zu reinigen.
- All components, especially moving parts, should be maintained and cleaned as necessary.
- Toutes les pièces détachées et en particulier les pièces mobiles, sont, si nécessaire, à entretenir et à nettoyer.
- Alle onderdelen, vooral de bewegende delen, kunnen, indien noodzakelijk, onderhouden en gereinigd worden.
- Es necesario limpiar y mantener en buen estado todas las diferentes piezas -especialmente las piezas móviles.
- Atenção! Perigo de ferimentos em peças componentes com cantos vivos e pontas obrigatórios para o funcionamento!
- Attenzione! Pericolo di lesioni dovute a componenti con spigoli vivi e punte per motivi funzionali!
- Будьте осторожны! Об острые края деталей и и наконечники можно порезаться!
- 注意！因功能需要而带有锋利的棱边和尖角的部件可能会带来受伤危险！
- Caso necessário, todas as peças individuais, especialmente peças móveis, tem que ser submetidas à manutenção e ser limpadas.
- Se necessario, tutti i singoli componenti, soprattutto le parti mobili, si devono eventualmente sottoporre a manutenzione e pulizia.
- Все детали, особенно подвижные, требуют ухода и чистки.
- 必要时应保养和清洁所有零件，尤指运动部件。

- Bei der Reifenmontage Profilrichtung links und rechts beachten!
- When mounting the tyres, please pay attention to the direction of the tread, left and right.
- Pour le montage des pneus, faire attention à la direction gauche et droite du profil.
- Let bij de bandenmontage op de profielrichting links en rechts.
- Al montar los neumáticos, tener en cuenta la dirección del perfil izquierdo y derecho.



- Ao proceder a montagem de pneus, levar em conta a direção de perfil à esquerda e à direita.
- Al momento del montaggio delle gomme si deve osservare la direzione del profilo (a sinistra e destra)!
- При монтаже шин обратите внимание на правое и левое направление протектора!
- 装配轮胎时应注意左右轮胎沟纹的方向！

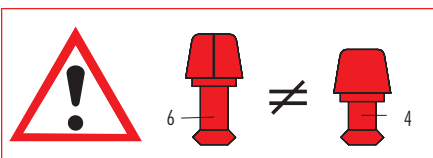
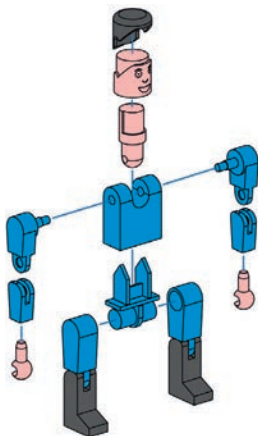
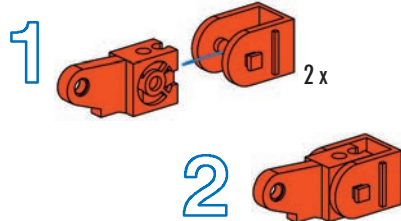
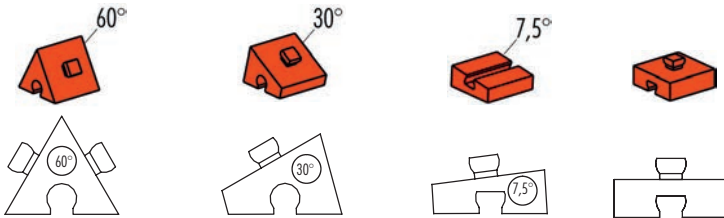
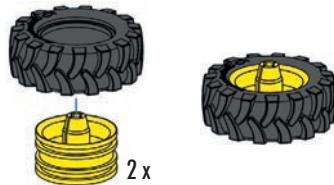

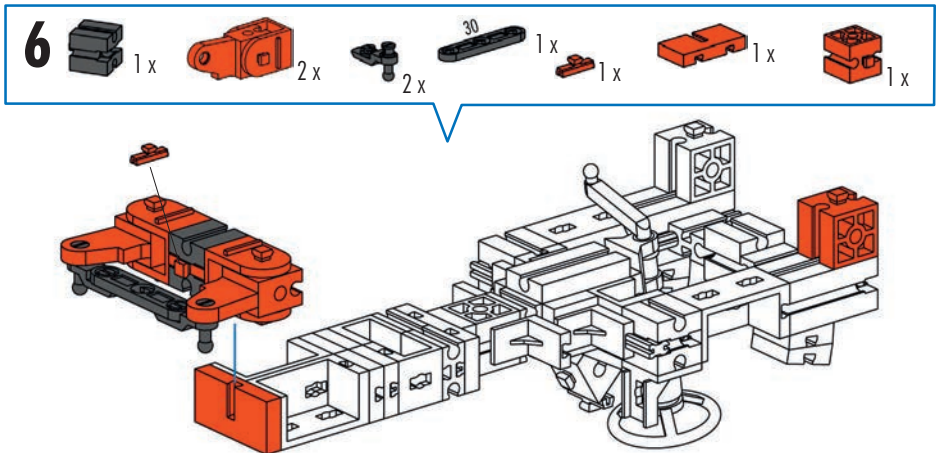
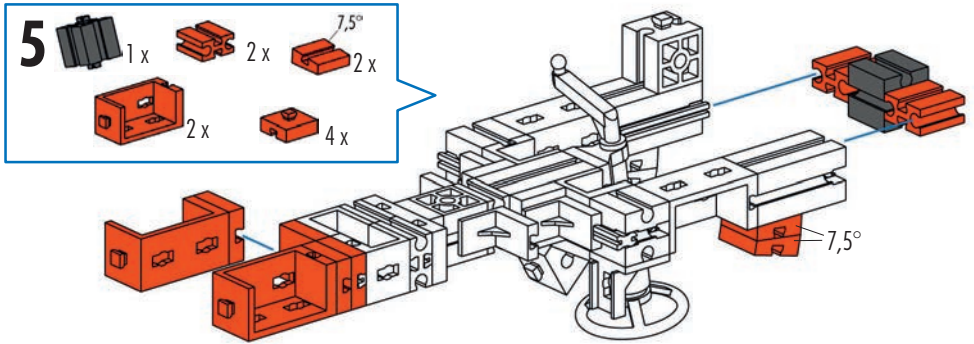
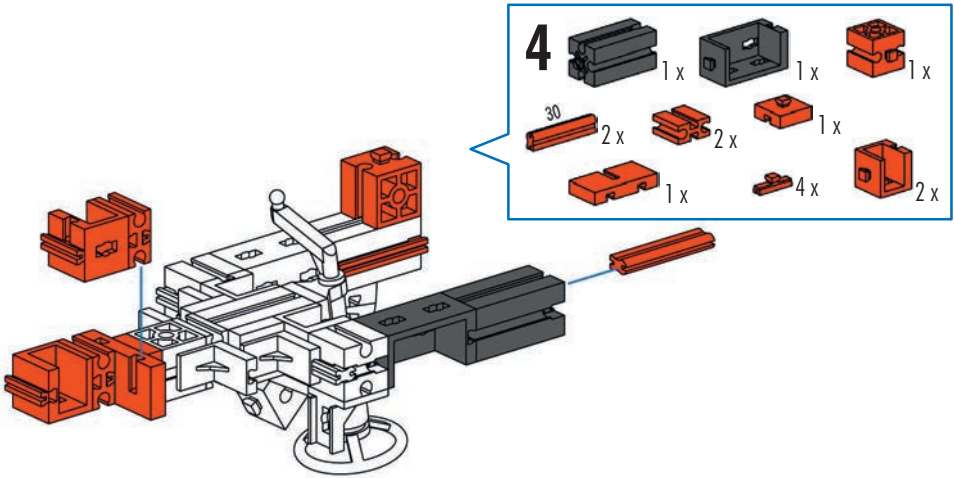

7

30 1x

45 3x

4
6x

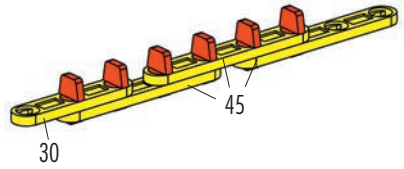

8



1x

2x

7

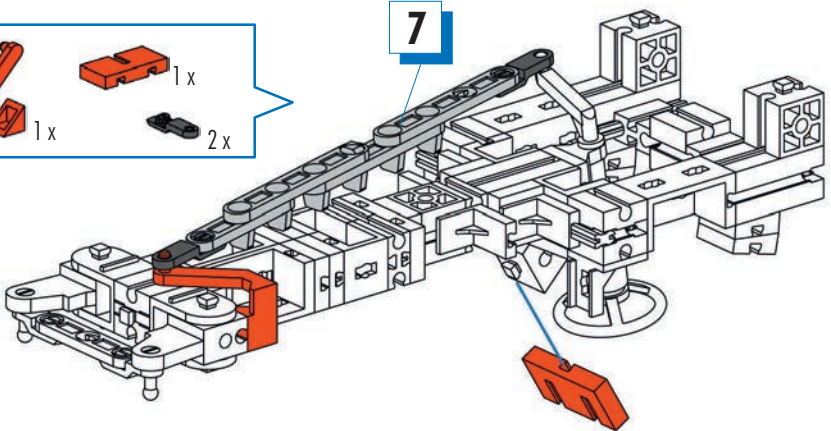

9

45 2x

4
4x

60°
2x

15 1x

3x

3x

1x

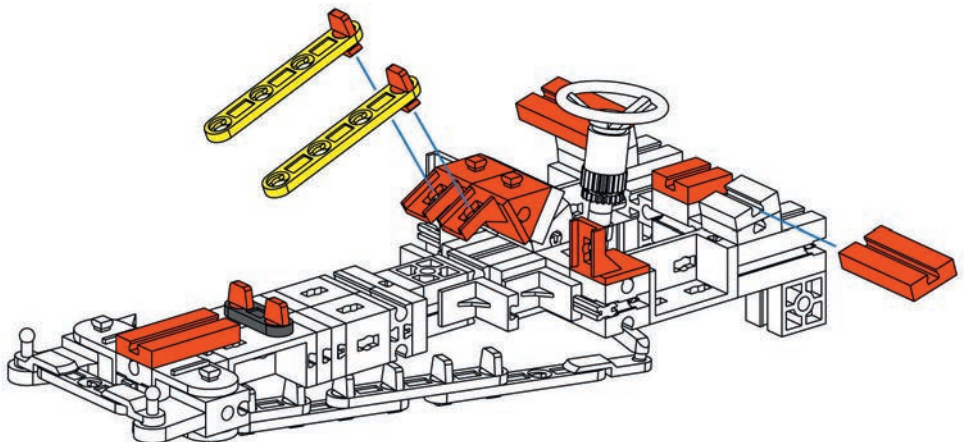

10

4 x



6
2 x

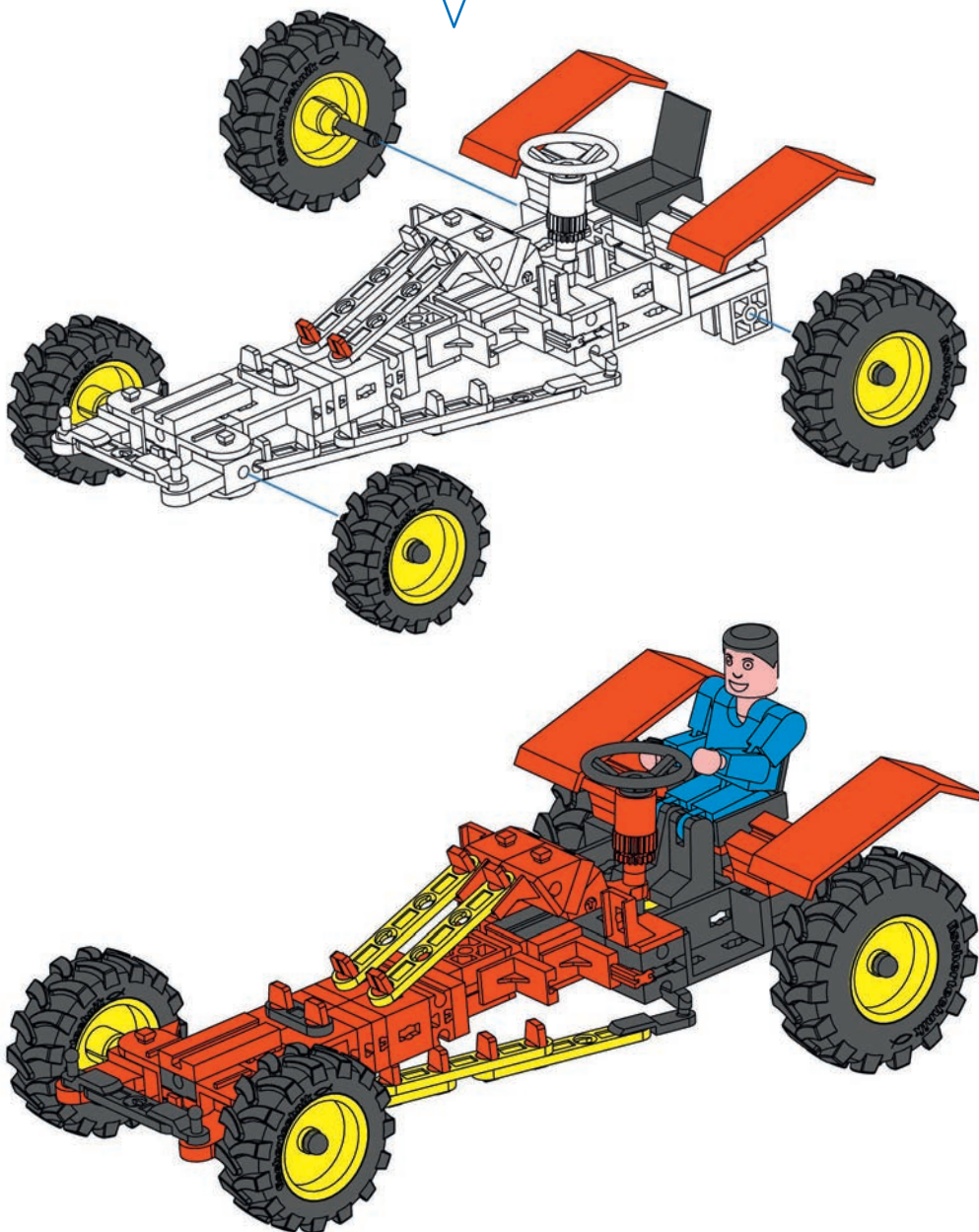

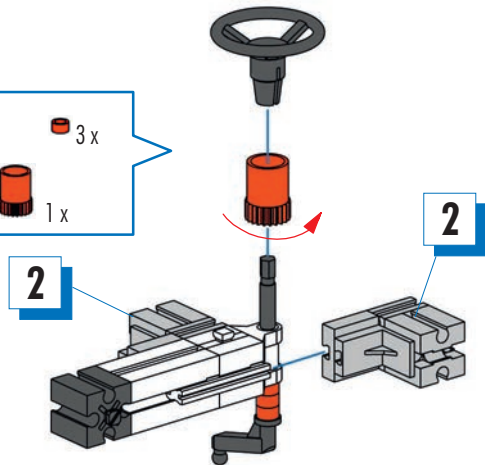
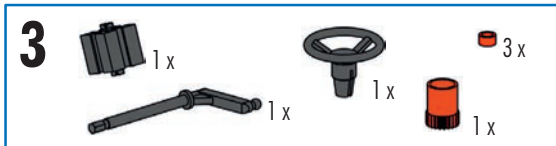
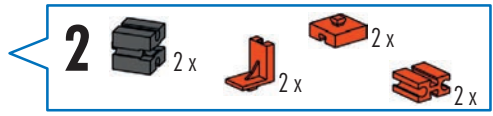
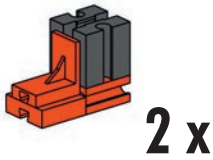
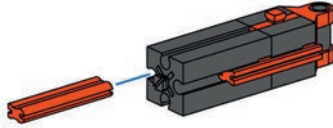
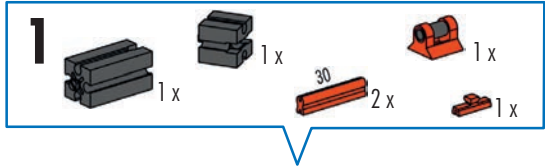

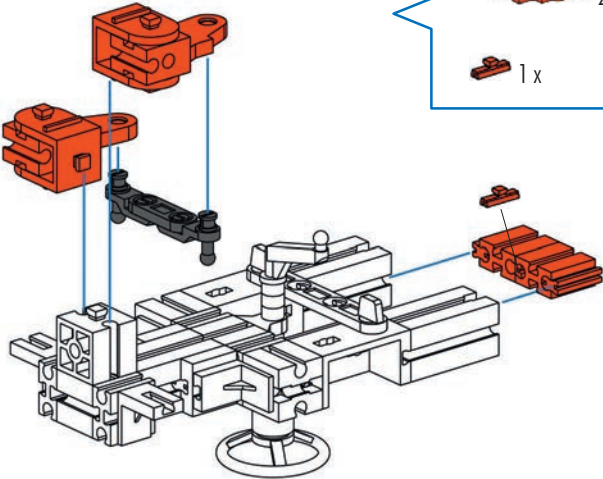
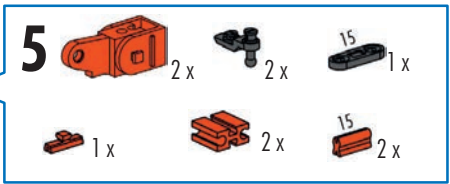
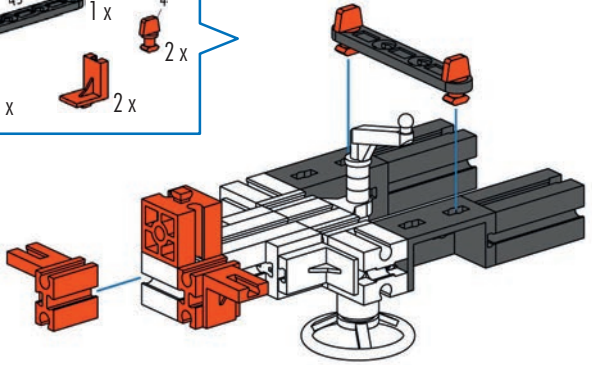
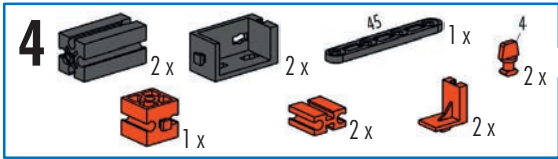

6

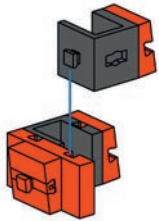
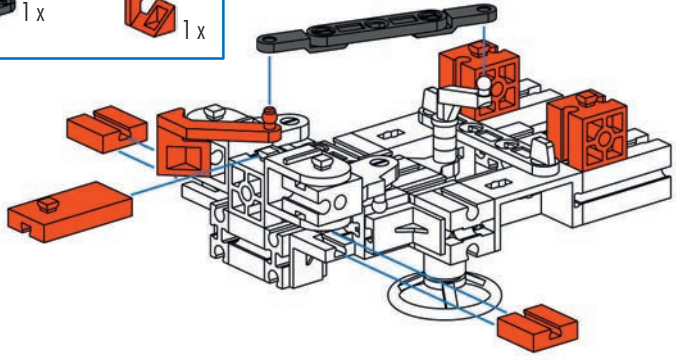
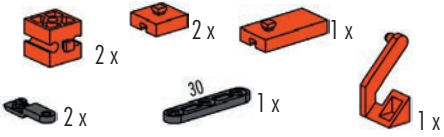

7

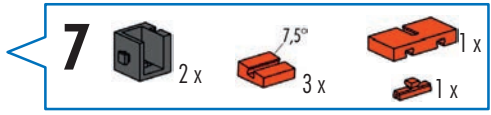
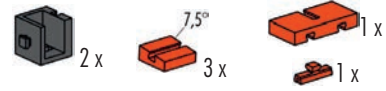

8

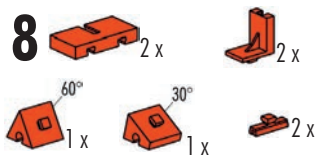

7

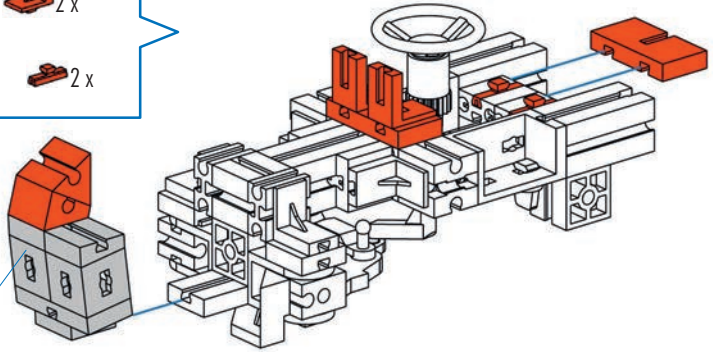

9

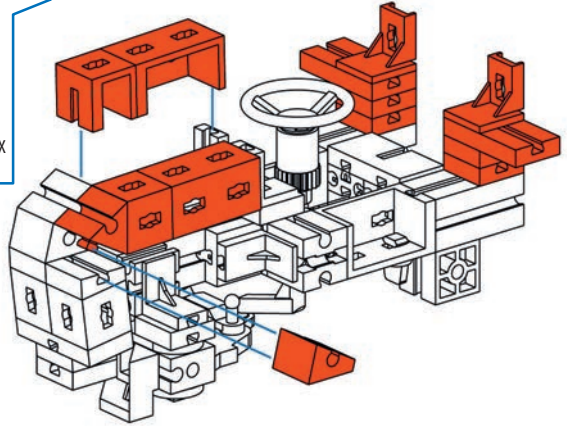
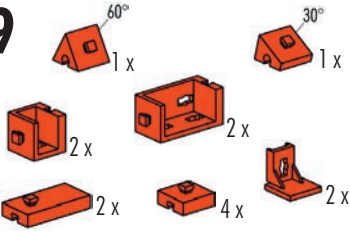

10

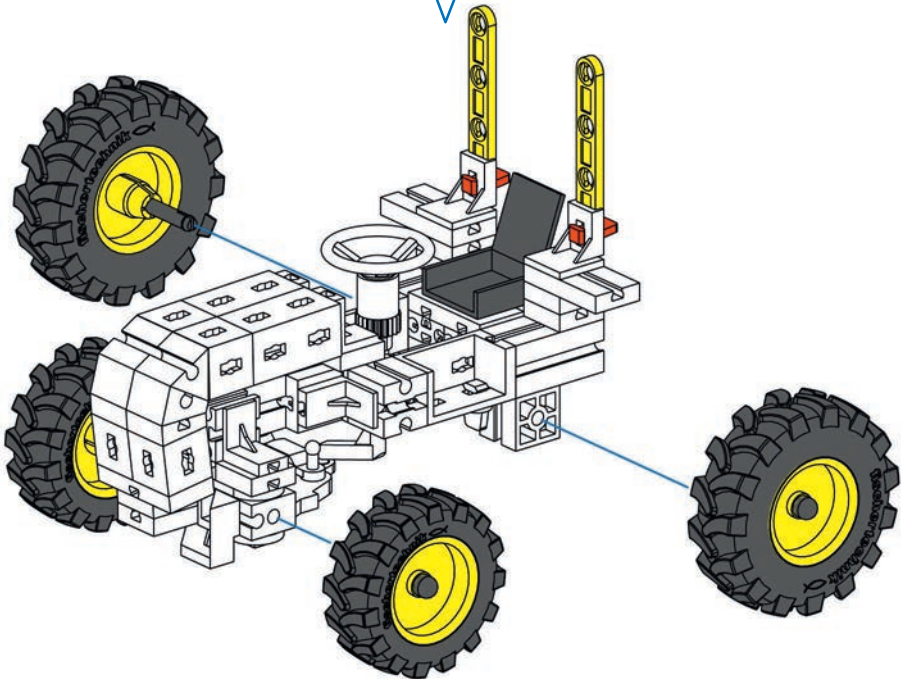
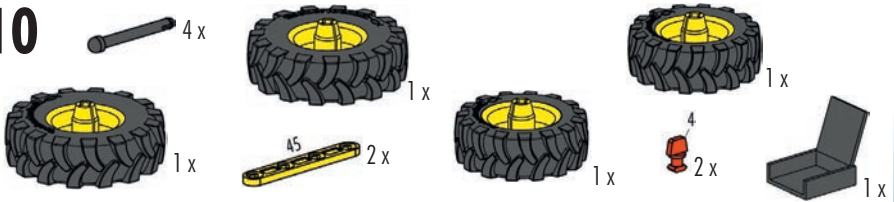

11

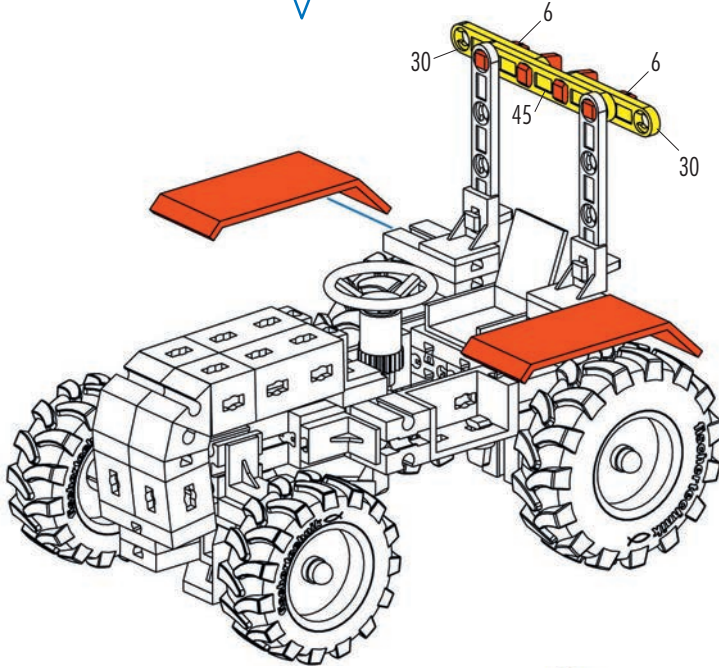



1

- 1x [Grey 1x4 Technic Brick]
- 1x [Grey 1x4 Technic Brick with Hole]
- 2x [Orange 30 Technic Pin]
- 1x [Orange 1x2 Technic Brick]
- 1x [Orange 1x2 Technic Brick with Hole]

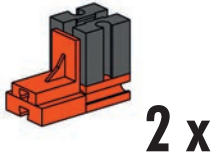
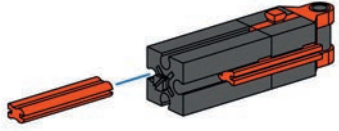

2

- 2x [Grey 1x4 Technic Brick]
- 2x [Orange 1x2 Technic Brick]
- 2x [Orange 1x2 Technic Brick with Hole]
- 2x [Grey 1x2 Technic Brick]

3

- 1x [Grey 1x4 Technic Brick]
- 1x [Grey Technic Arm]
- 1x [Grey Steering Wheel]
- 1x [Orange Technic Pin]
- 3x [Orange Technic Pin]

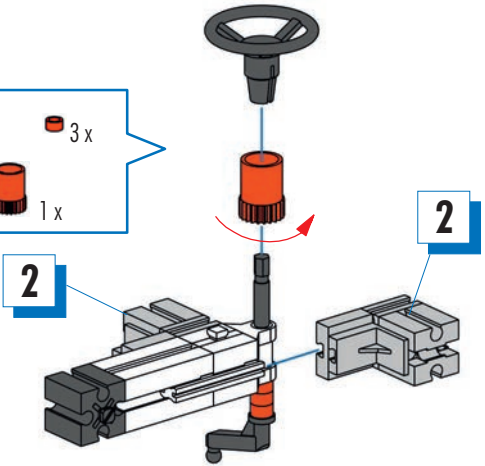

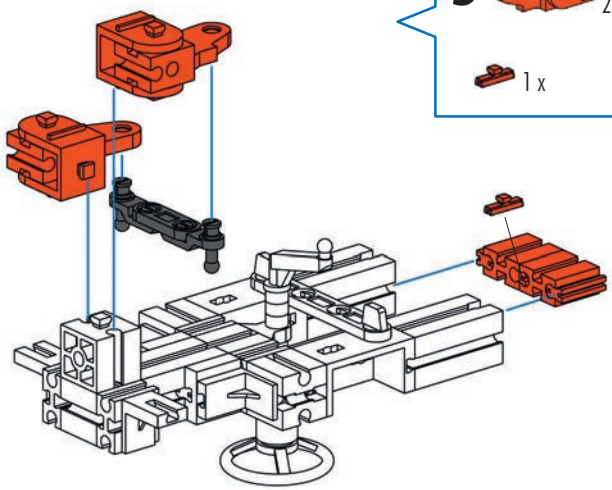
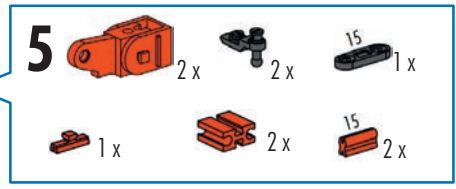
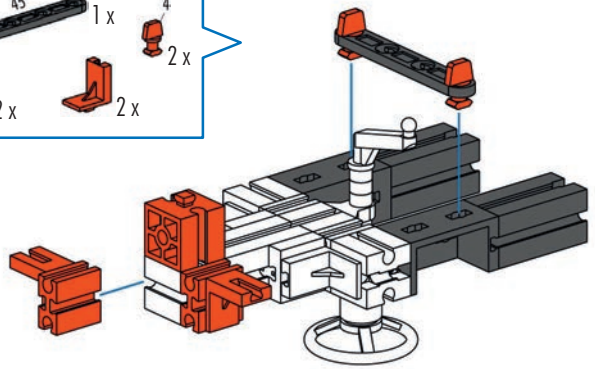
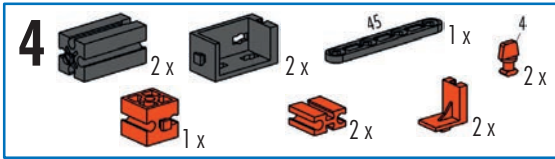

- 6**
- 30 1 x
 - 2 x
 - 2 x
 - 2 x
 - 1 x
 - 1 x

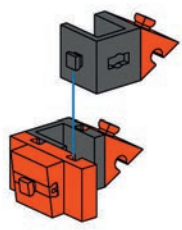
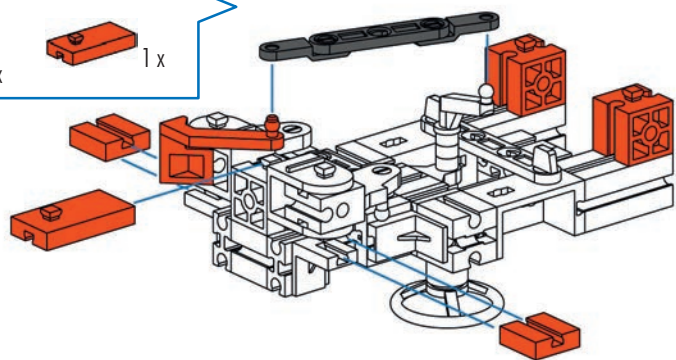

- 7**
- 2 x
 - 60° 2 x
 - 1 x
 - 7,5° 1 x
 - 1 x

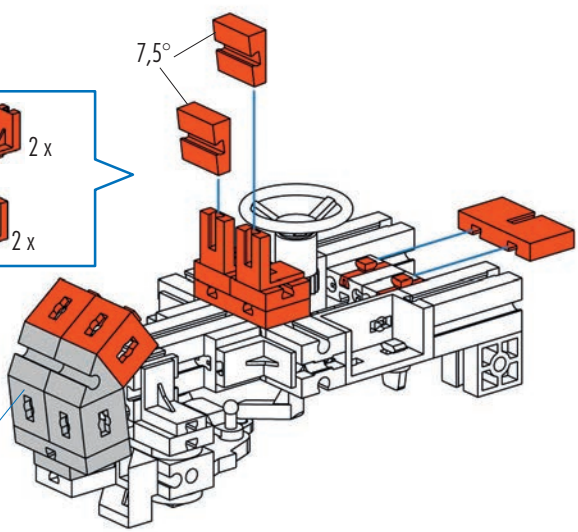

- 8**
- 2 x
 - 2 x
 - 2 x
 - 7,5° 2 x
 - 2 x
 - 2 x

7

9

- 7,5° 2x
- 30° 2x
- 2x
- 2x
- 4x
- 2x
- 45 2x
- 4 2x

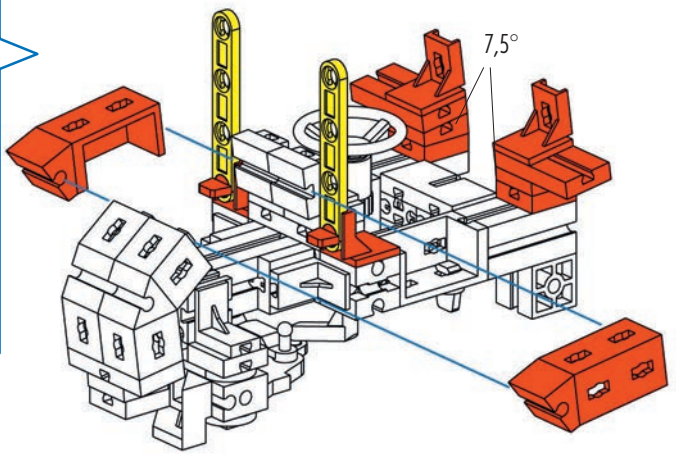

10

- 1x
- 1x
- 1x
- 1x
- 4x
- 2x
- 1x

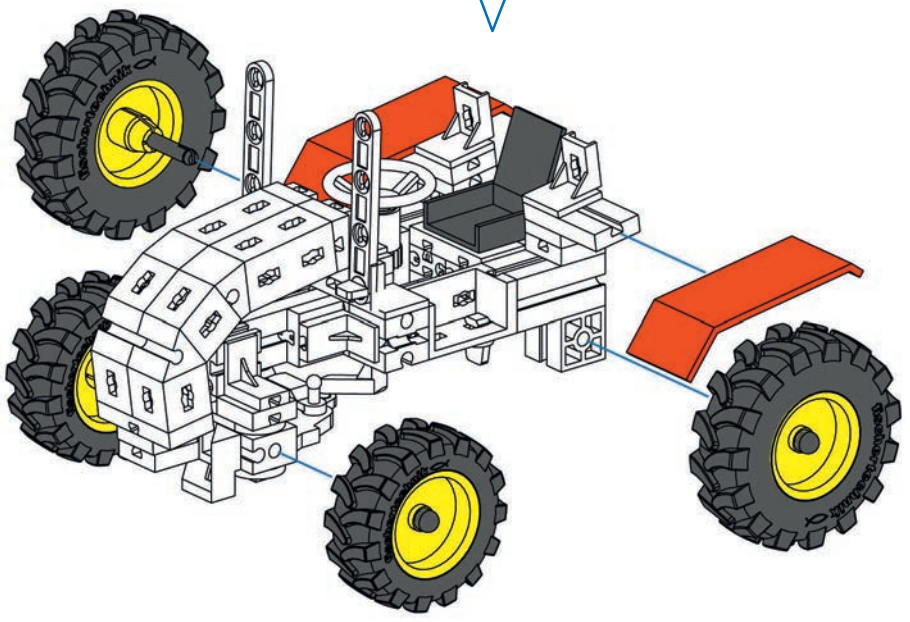

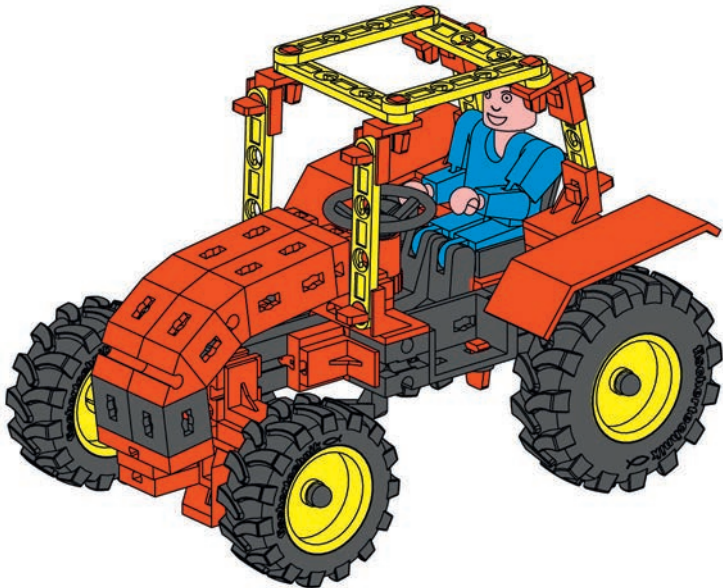
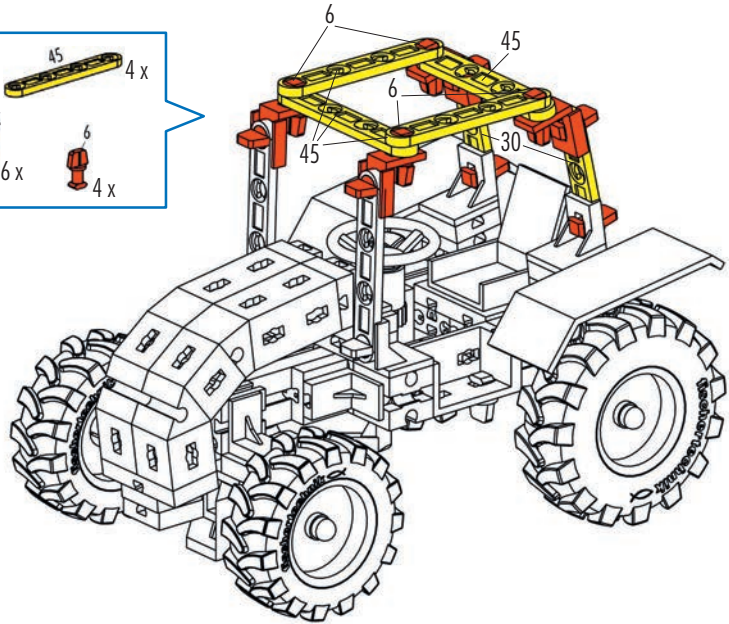
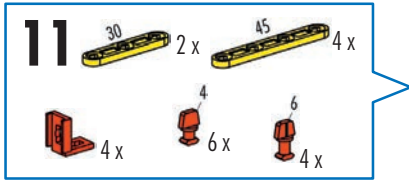

fischertechnik GmbH
Klaus-Fischer-Straße 1
72178 Waldachtal
Germany

Phone +49 74 43/12-43 69
Fax +49 74 43/12-45 91
info@fischertechnik.de
www.fischertechnik.de

fischertechnik 

BASIC

