

fischertechnik 

COMPUTING

Bauanleitung
Assembly instruction
Instructions de montage
Bouwhandleiding
Instrucciones de construcción
Manual de montagem
Istruzioni di montaggio
Инструкция по сборке
安装说明书

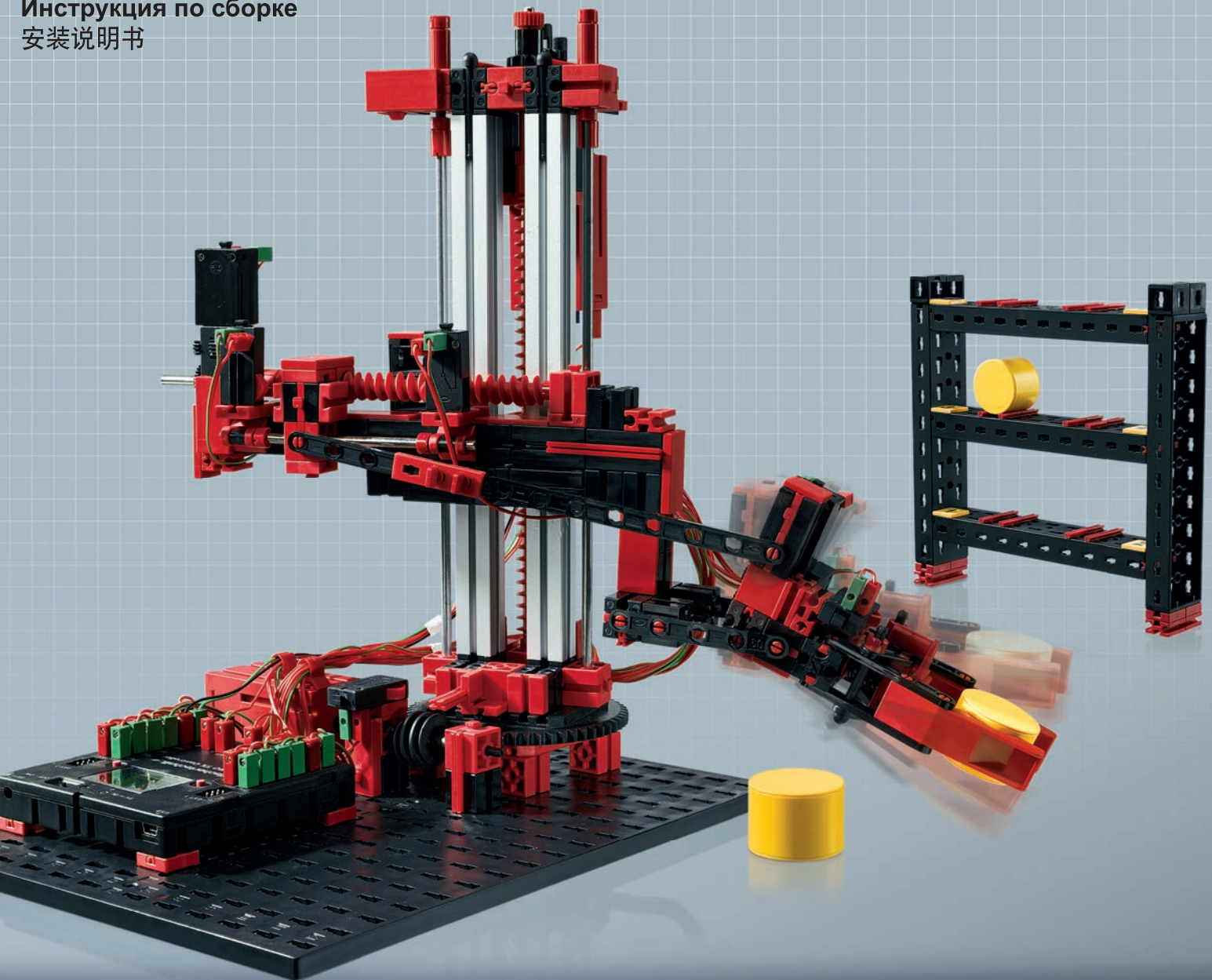

ROBO TX Automation Robots

4 MODELS
MODELS

Inhalt
Contents
Contenu

Inhoud
Contenido
Conteúdo

Contenuto
Содержание
目录

Einzelteilübersicht / Spare parts list / Liste des pièces détachées / Onderdelenoverzicht / Lista da piezas / Resumo de peça individual /
Singoli componenti / Перечень деталей / 零件概览 1

Montagetips / Tips for assembly / Tuvaux pour le montage / Montagetips / Consejos para el montaje / "Dicas" para montagem /
Consigli per il montaggio / Советы по сборке / 装配建议 3

Sicherheitshinweise / Safety Information / Consignes de sécurité / Veiligheidsrichtlijnen / Indicaciones de seguridad / Observações sobre segurança /
Informazioni per la sicurezza / Указания по технике безопасности / 安全指 4

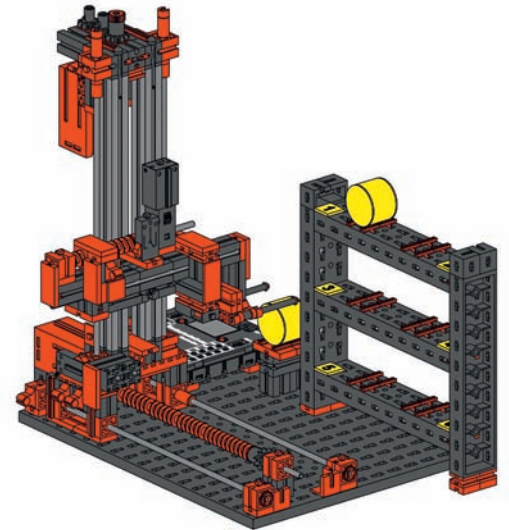
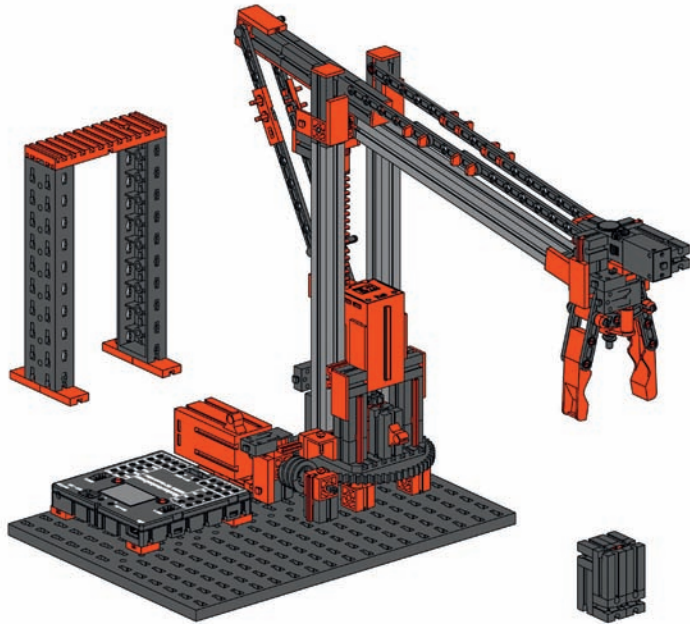

Greifroboter / Gripper robot / Robot à grappin / Grijsrobot /
Robot manipulador / Robò de garras / Robot con braccio /
Робот-манипулятор / 抓件机器人 5

Hochregal / High bay storage rack / Rayonnage haut /
Stellingmagazijn / Almacén elevado / Depósito de
prateleira alta / Magazzino alto / Высотный
стеллажный склад / 高货架仓库 14

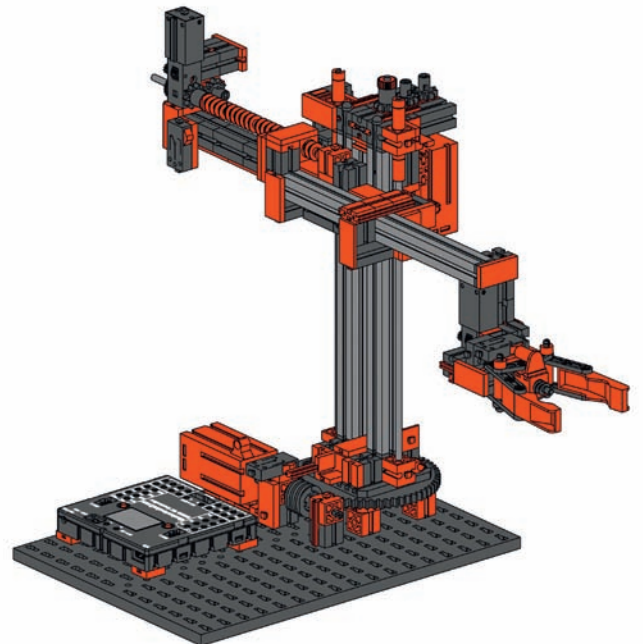
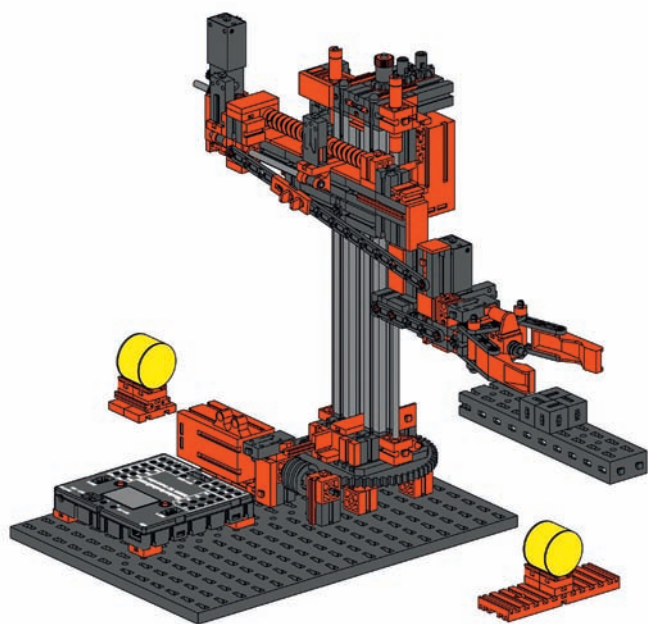











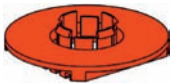



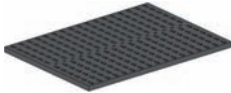













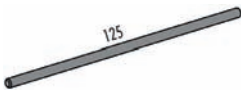





























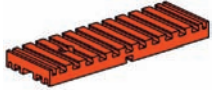



Schwenkgreifer / Pivoting gripper / Grappin basculant /
Zwenkgrijper / Pinza oscilante / Garras rotativas /
Pinza orientabile / Поворотный захват /
回转抓爪 27

3-Achs-Roboter / 3-axis robot / Robot à 3 axes /
3-assige robot / Robot de 3 ejes / Robò de 3 eixos /
Robot a 3 assi / Трёхосный робот / 3 轴机器 39





Einzelteilübersicht
Spare parts list
Liste des pièces détachées

Onderdelenoverzicht
Lista da piezas
Resumo de peça individual





Singoli componenti
Перечень деталей
零件概览

	10 497 6 x		31 391 1 x		32 882 12 x		35 977 1 x
	31 021 1 x		31 426 1 x		32 985 1 x		36 035 1 x
	31 023 2 x		31 436 5 x		35 031 1 x		36 323 12 x
	31 031 1 x		31 597 2 x		35 049 6 x		36 334 6 x
	31 032 1 x		31 668 2 x		35 061 1 x		36 443 1 x
	31 036 1 x		31 707 6 x		35 063 4 x		36 819 4 x
	31 058 1 x		31 848 12 x		35 072 1 x		36 913 6 x
	31 060 15 x		31 915 2 x		35 073 2 x		36 914 4 x
	31 061 8 x		31 982 74 x		35 112 2 x		36 922 6 x
	31 063 1 x		31 983 6 x		35 113 1 x		36 952 3 x
	31 078 2 x		32 064 21 x		35 409 3 x		37 157 2 x
	31 082 1 x		32 330 13 x		35 668 1 x		37 237 25 x
	31 226 3 x		32 854 5 x		35 697 1 x		37 468 18 x
	31 330 5 x		32 859 1 x		35 945 3 x		37 679 12 x
	31 336 22 x		32 870 4 x		35 969 8 x		37 783 6 x
	31 337 26 x		32 879 18 x		35 973 1 x		37 858 3 x
	31 390 1 x		32 881 19 x		35 975 2 x		37 925 4 x

Einzelteilübersicht
Spare parts list
Liste des pièces détachées





	37 926 11 x
	38 216 2 x
	38 236 6 x
	38 240 7 x
	38 241 6 x

Onderdelenoverzicht
Lista da piezas
Resumo de peça individual

	38 242 1 x
	38 246 6 x
	38 416 2 x
	38 428 3 x
	38 464 1 x

	38 543 2 x
	38 546 4 x
	107 355 3 x
	107 436 6 x
	113 853 2 x

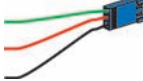
Singoli componenti
Перечень деталей
零件概览

	135 484 2 x
	137 096 2 x
	137 125 2 x
	143 289 2 x
	143 389 1 x

Montagetipps
Tips for assembly
Tuyaux pour le montage

Montagetips
Consejos para el montaje
"Dicas" para montagem

Consigli per il montaggio
Советы по сборке
装配建议

<p>Kabel und Stecker Plugs and cables Fiches et des câbles</p>	<p>Stekkers en cables Enchufes en cables Cabos e contatos</p>	<p>Cavi e connettori Провода и штекеры 电缆和插头</p>
--	---	--

1

2 x 20 cm
3 x 45 cm
3 x 60 cm
3 x 80 cm

4

2

5

2 x 20 cm
2 x 45 cm
3 x 60 cm
3 x 80 cm
1 x 45 cm

3

1 x 45 cm

1

1 x

2

1

2

4 x

1

2



Sicherheitshinweise Safety Information Consignes de sécurité

Veiligheidsrichtlijnen Indicaciones de seguridad Observações sobre segurança

Informazioni per la sicurezza Указания по технике безопасности 安全指南

- Die Anschlussklemmen dürfen nicht kurzgeschlossen werden.
 - Drähte nicht in Steckdose einführen!
 - Ladegerät regelmäßig auf Schäden überprüfen. Bei einem Schaden darf das Ladegerät bis zur vollständigen Reparatur nicht mehr verwendet werden.
 - Alle elektrischen Bauteile (Motoren, Lampen, ROBO TX Controller) dürfen ausschließlich an Stromversorgungen von Fischertechnik angeschlossen werden.
- Do not short circuit the connecting terminals!
 - Do not insert the wires into an outlet!
 - Regularly inspect battery charger for damage. If the battery charger has been damaged, it should not be used further until fully repaired.
 - No electrical components (motors, lamps, ROBO TX Controller) are to be connected to any other power supply than that provided by Fischertechnik.
- Il est interdit de court-circuiter les bornes de raccordement.
 - Contrôlez régulièrement le chargeur en vue d'éventuelles détériorations
 - En cas de détérioration, il est interdit d'utiliser le chargeur jusqu'à ce qu'il ait été intégralement réparé
 - Tous les composants électriques (moteurs, lampes, ROBO TX Controller) ne doivent être branchés aux alimentations électriques uniquement que par la société Fischertechnik.
- De aansluitklemmen mogen niet worden kortgesloten.
 - Geen draden in de contactdoos steken!
 - Laadtoestel regelmatig controleren op schade. Bij schade mag het laadtoestel niet meer gebruikt worden tot het volledig hersteld is.
 - Alle elektrische componenten (motoren, lampen, ROBO TX Controller) mogen uitsluitend op stroomvoorzieningen van fischertechnik worden aangesloten.
- Los bornes de conexión no pueden ser puestos en cortocircuito.
 - No introducir hilos en la toma de corriente!
 - Comprobar con regularidad si el cargador presenta daños. En caso de presentar daños, el cargador no debe volver a ser utilizado hasta que esté completamente reparado.
 - Todos los componentes eléctricos (motores, luces, ROBO TX Controller) deben conectarse a la alimentación de corriente de la técnica Fischer exclusivamente.
- Os terminais de conexão não devem ser curto-circuitados.
 - Nunca introduzir fios na tomada!
 - Verificar regularmente se o carregador apresenta danos. Em caso de dano, o carregador não deverá ser utilizado enquanto não estiver plenamente consertado.
 - Todas as peças componentes elétricas (motores, lâmpadas, ROBO TX Controller) só podem ser exclusivamente conectadas em abastecimentos de corrente da Fischertechnik.
- I morsetti di allacciamento non devono essere cortocircuitati.
 - Non inserire i fili nella presa elettrica.
 - Controllare periodicamente se il caricabatterie presenta dei danni. In caso di danni, il caricabatterie non deve più essere utilizzato fino alla riparazione.
 - Tutti i componenti elettrici (motori, lampadine, ROBO TX Controller) devono essere collegati esclusivamente ad alimentatori fischertechnik.
- Не замыкайте накоротко соединительные клеммы.
 - Не вставляйте в розетку провода!
 - Регулярно проверяйте зарядное устройство на отсутствие повреждений. При наличии повреждений использовать зарядное устройство до выполнения его полного ремонта не разрешается.
 - Все электрические детали (электромоторы, лампочки.) можно подключать только к источникам электропитания от fischertechnik.
- 接线柱不允许被短路。
 - 禁止将金属丝插入插座！
 - 经常检查充电器是否有损坏情况。如果充电器有损，直到完全修好为止不可以再使用。
 - 只允许将所有电气部件（传感器，电机）与慧鱼技术产品的电源装置相连接

- Die Modelle dürfen nur an Geräte der Schutzklasse II angeschlossen werden, die mit dem entsprechenden Symbol gekennzeichnet sind.
- Ensure that the models are connected only to equipment rated in protection category II and marked with the appropriate symbol.
- Le raccordement des maquettes est uniquement permis à des appareils dotés de la catégorie de protection II qui portent le pictogramme respectif.
- De modellen mogen alleen op apparaten uit beschermingsklasse II worden aangesloten, die zijn voorzien van het bijbehorende symbol.
- Los modelos sólo pueden ser conectados a aparatos de clase de protección II que están identificados con el símbolo correspondiente.
- Os modelos somente devem ser conectados nos aparelhos da classe de proteção II, que são identificados com o símbolo correspondente.
- I modelli devono essere collegati solo ad apparecchi della classe di protezione II, contrassegnati con il relativo simbolo.
- Модели можно подключать только к приборам класса защиты II, обозначенным соответствующим знаком.
- 这些模型只允许连接到具有防护等级 II 的装置上，这类装置被用相应的符号进行了标识。

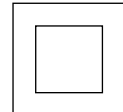

- Achtung! Verletzungsgefahr an Bauteilen mit funktionsbedingten scharfen Kanten und Spitzen!
- Atenção! Perigo de ferimentos em peças componentes com cantos vivos e pontas obrigatórios para o funcionamento!
- Caution! Be careful not to hurt yourself on components with sharp or pointed edges!
- Attenzione! Pericolo di lesioni dovute a componenti con spigoli vivi e punte per motivi funzionali!
- Attention! Risque de blessure sur les éléments comportant des arêtes et o pointes vives indispensables au bon fonctionnement!
- Будьте осторожны! Об острые края деталей и и наконечники можно порезаться!
- Let op! U kunt zich bezeren aan bouwstenen met scherpe randen of punten!
- 注意！因功能需要而带有锋利的棱边和尖角的部件可能会带来受伤危险！
- Attenzione! Esiste il pericolo di lesione con i pezzi di costruzione che hanno bordi e punte spigolosi necessari per la funzionalità del pezzo!

- Alle Einzelteile, insbesondere bewegliche Teile sind falls notwendig zu warten und zu reinigen.
- Caso necessário, todas as peças individuais, especialmente peças móveis, tem que ser submetidas à manutenção e ser limpadas.
- All components, especially moving parts, should be maintained and cleaned as necessary.
- Se necessario, tutti i singoli componenti, soprattutto le parti mobili, si devono eventualmente sottoporre a manutenzione e pulizia.
- Toutes les pièces détachées et en particulier les pièces mobiles, sont, si nécessaire, à entretenir et à nettoyer.
- Все детали, особенно подвижные, требуют ухода и чистки.
- Alle onderdelen, vooral de bewegende delen, kunnen, indien noodzakelijk, onderhouden en gereinigd worden.
- 必要时应保养和清洁所有零件，尤指运动部件。
- Es necesario limpiar y mantener en buen estado todas las diferentes piezas - especialmente las piezas móviles.

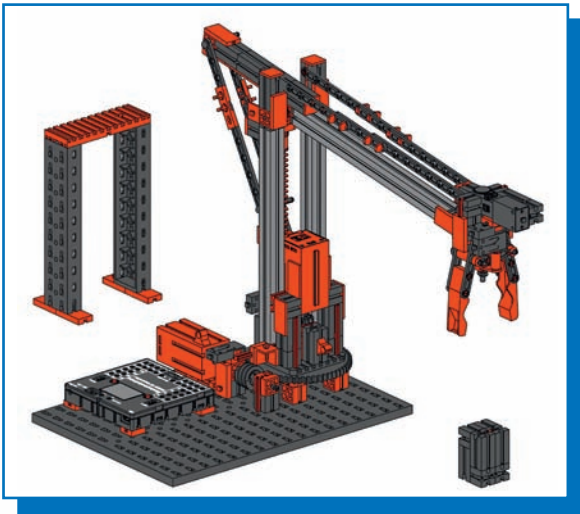

Greifroboter
Gripper robot
Robot à grappin

Grijprobot
Robot manipulador
Robò de garras

Robot con braccio
Робот-манипулятор
抓件机器人

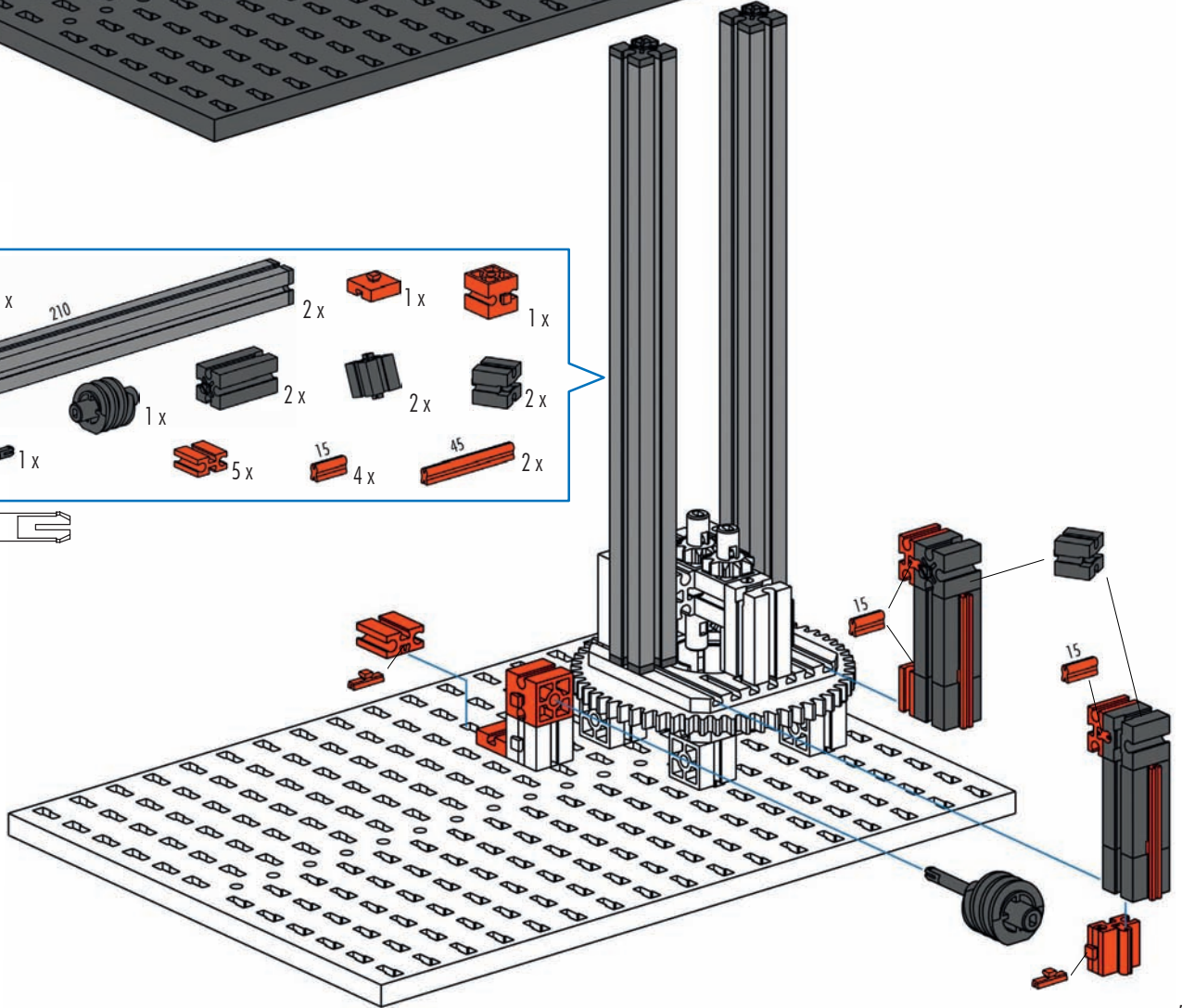
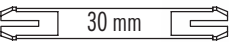
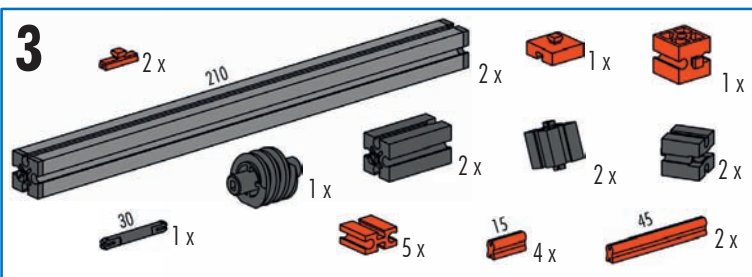
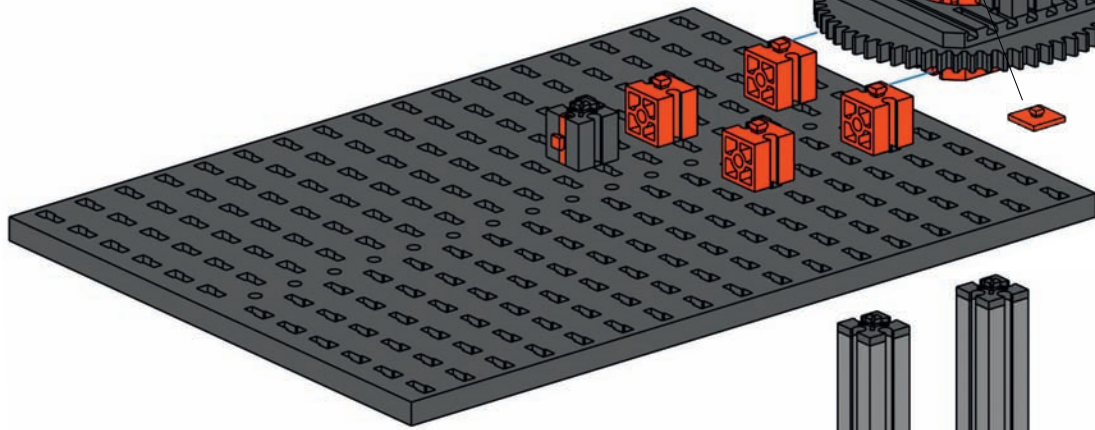
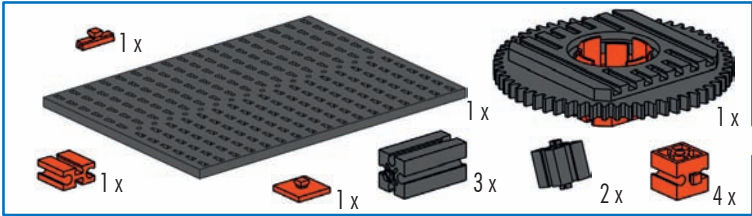
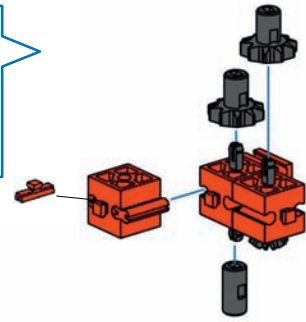
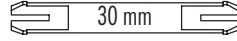
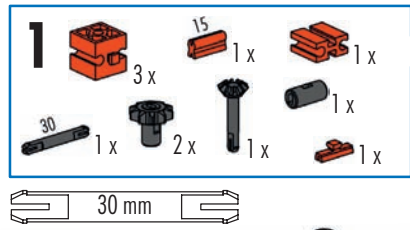

4

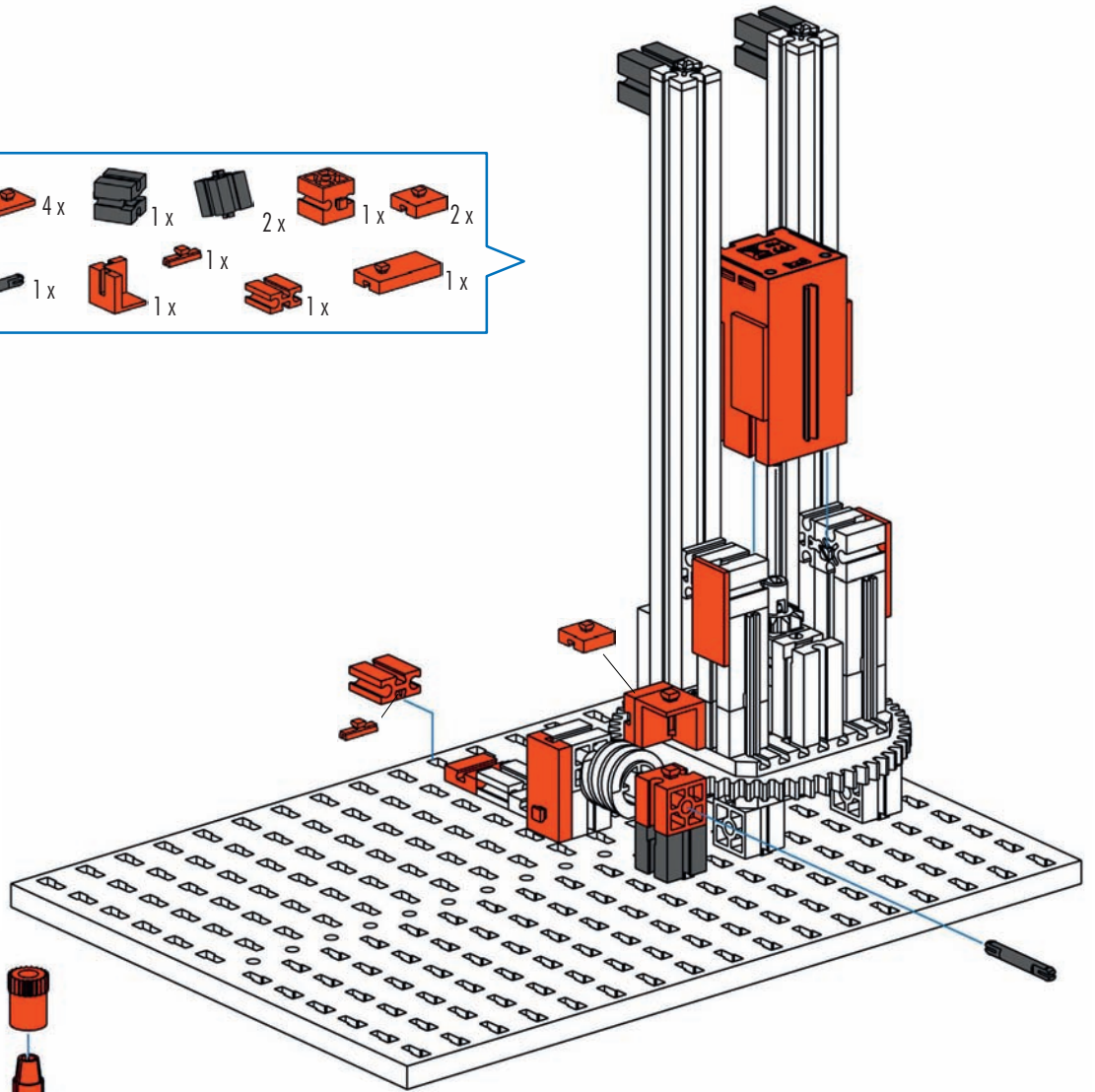
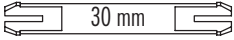
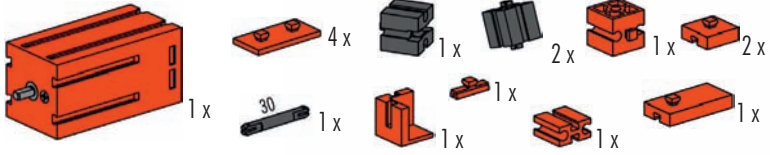

200 mm

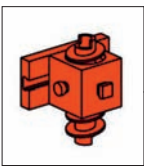

5

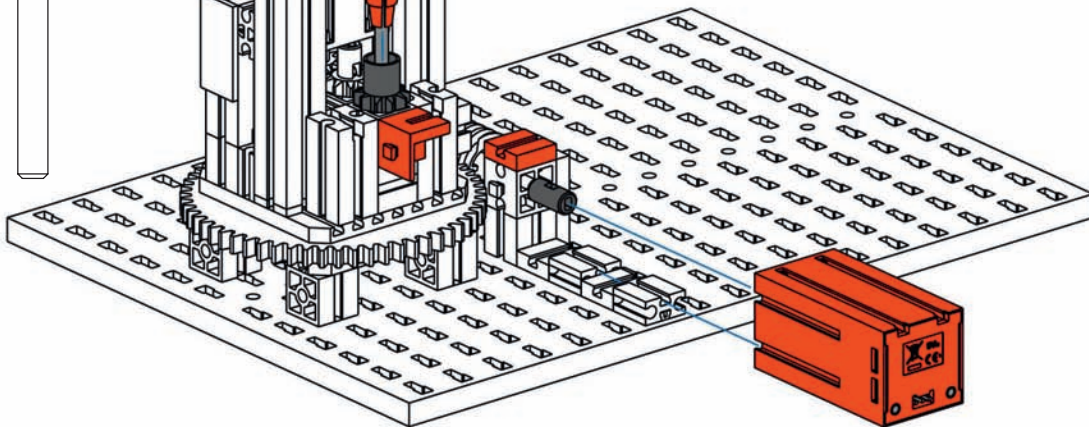
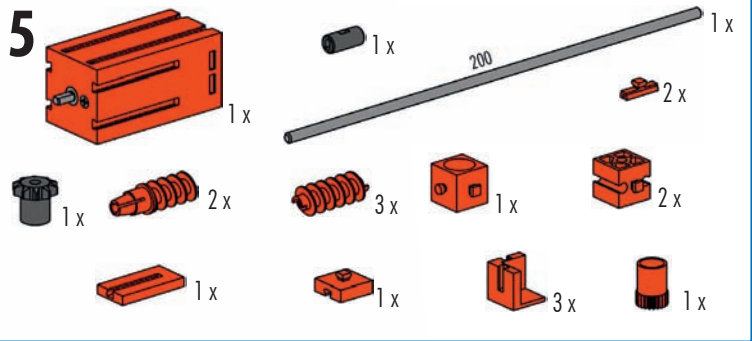

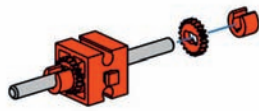

6 60 1 x 1 x 1 x 2 x 2 x

60 mm

7 120 2 x 1 x 1 x 1 x 1 x 15 3 x 1 x 2 x 1 x

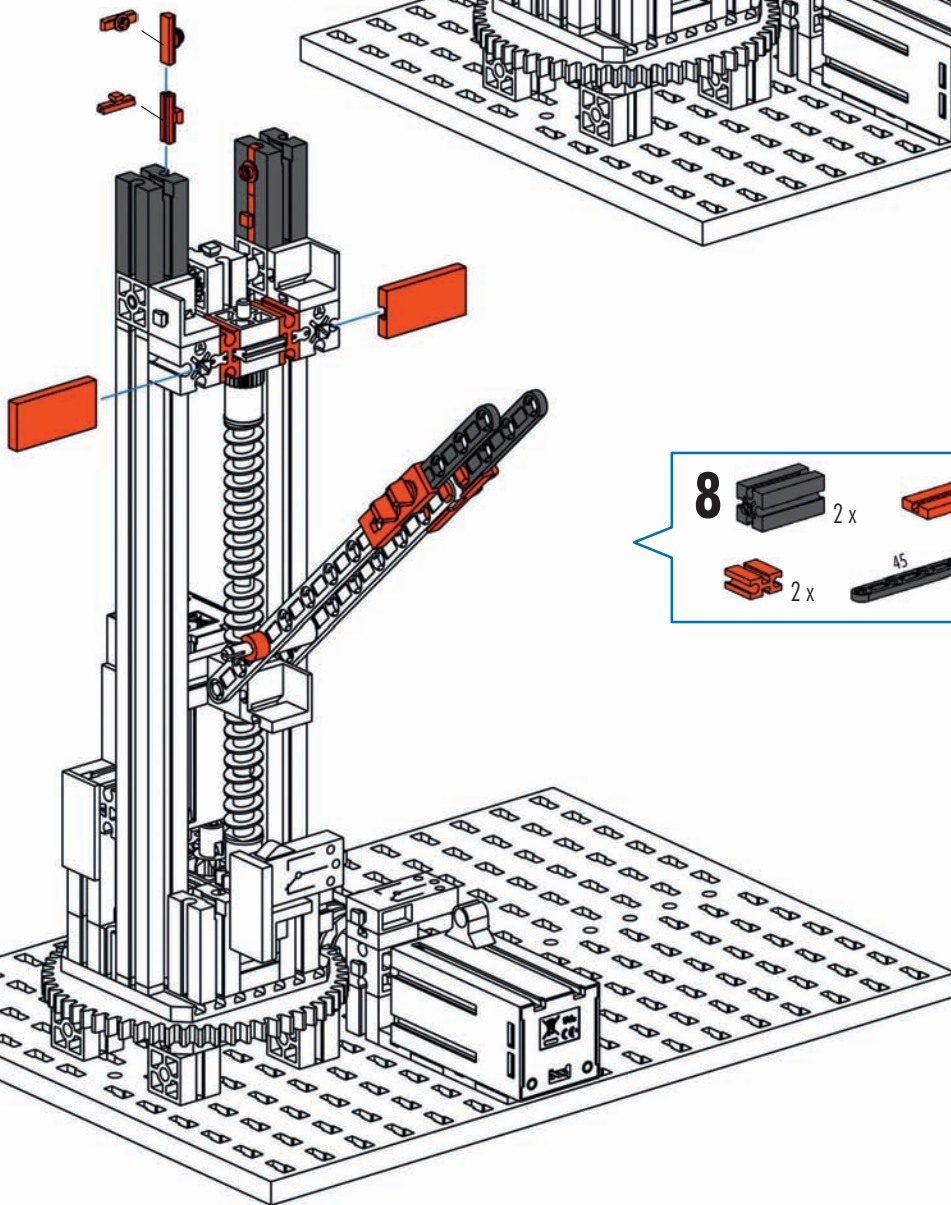
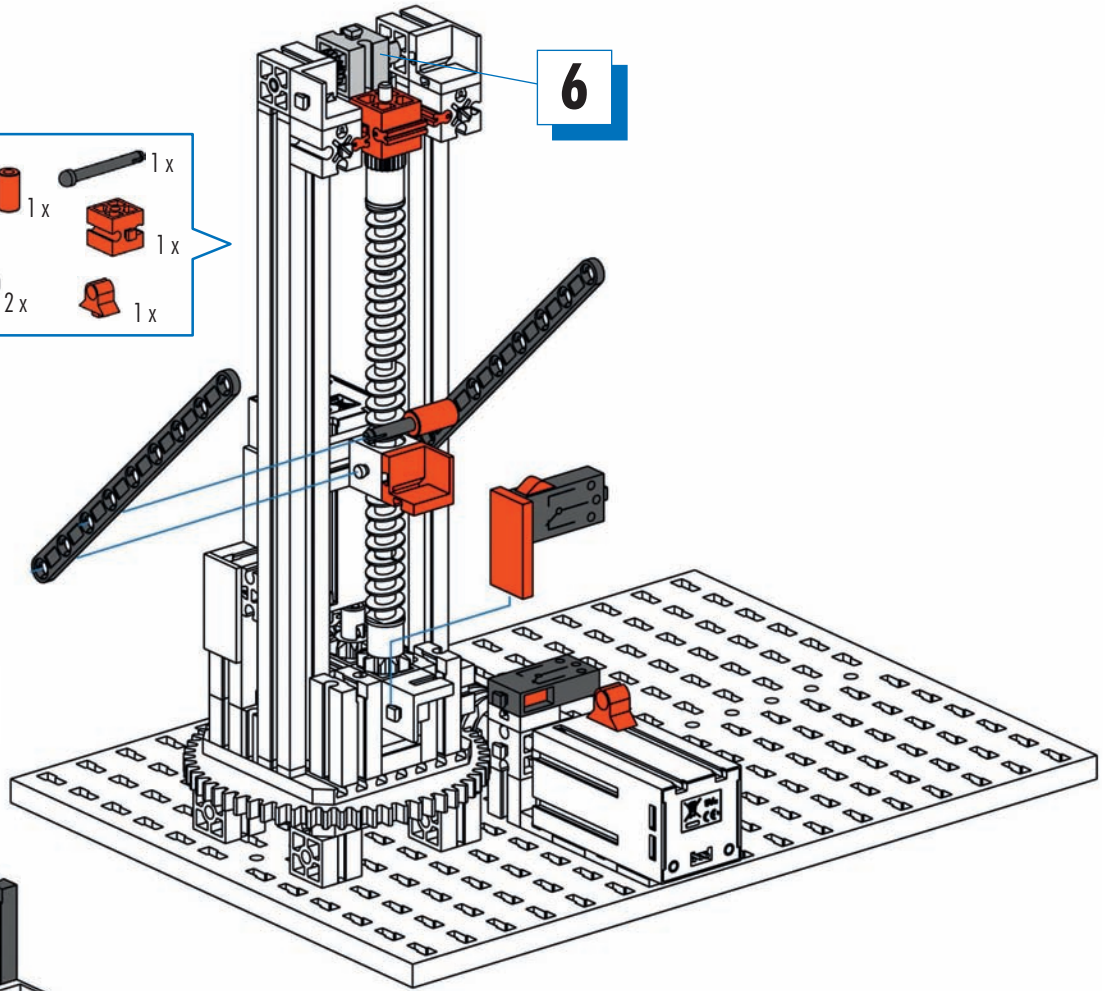

8 2 x 2 x 2 x 2 x 1 x 2 x 45 2 x 2 x 2 x 4 x

9

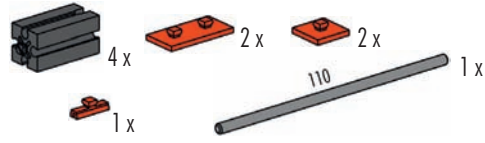

110 mm

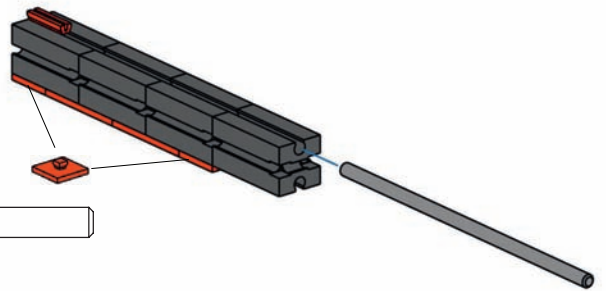

10

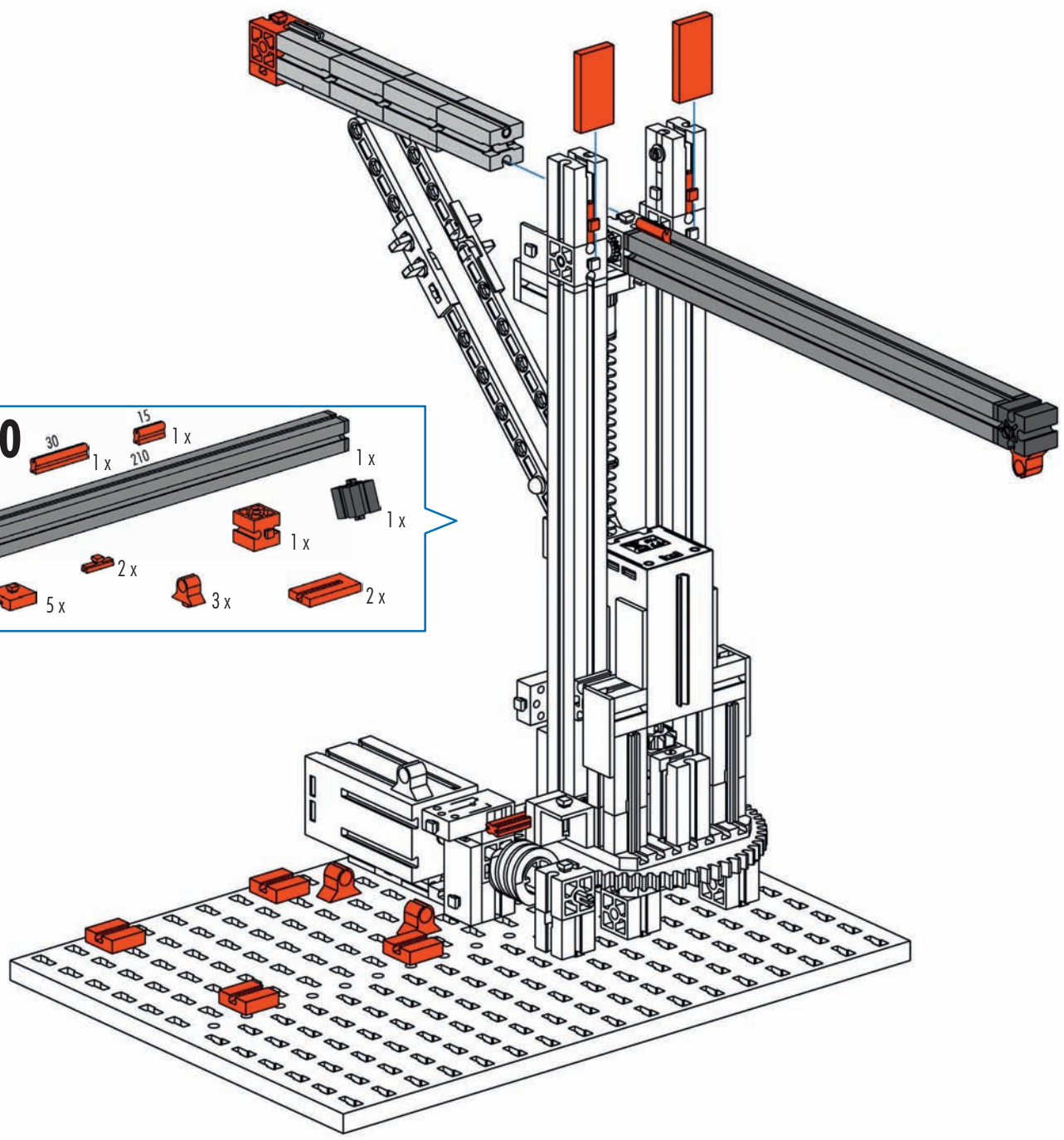
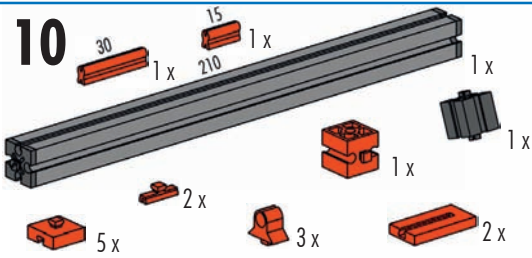

11

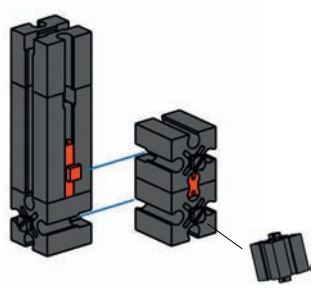

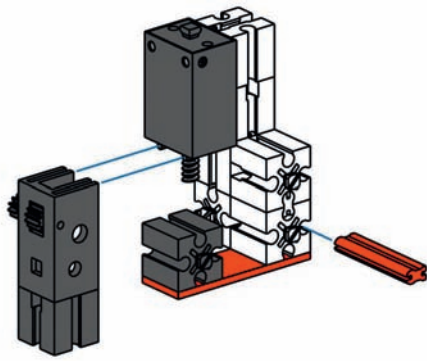

- 12**
- 1x [grey motor]
 - 1x [grey motor housing]
 - 1x [grey connector]
 - 1x [grey connector]
 - 1x [orange Technic beam 1x5]
 - 1x [orange Technic beam 30]

- 13**
- 2x [grey connector]
 - 1x [grey axle pin]
 - 2x [orange Technic pin]

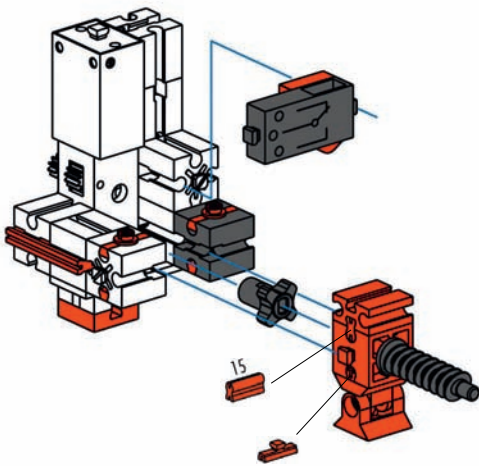
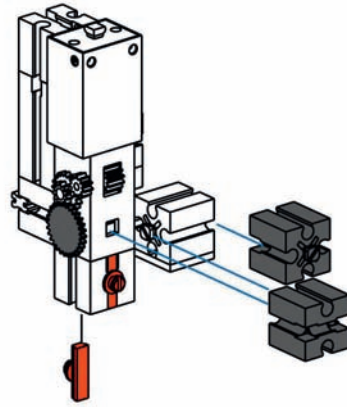

- 14**
- 1x [grey connector]
 - 1x [grey motor housing]
 - 2x [orange Technic pin]
 - 1x [orange Technic pin]
 - 1x [orange Technic pin]
 - 1x [orange Technic pin]
 - 1x [orange Technic pin]
 - 4x [orange Technic pin]
 - 1x [orange Technic beam 15]
 - 1x [orange Technic beam 30]
 - 1x [orange Technic pin]
 - 1x [grey Technic pin]
 - 1x [grey axle pin]

- 15**
- 1x [orange Technic pin]
 - 2x [orange Technic pin]
 - 2x [orange Technic beam 2x5]
 - 2x [orange Technic pin]
 - 2x [orange Technic pin 15]
 - 2x [grey Technic beam 45]
 - 2x [grey Technic axle pin]

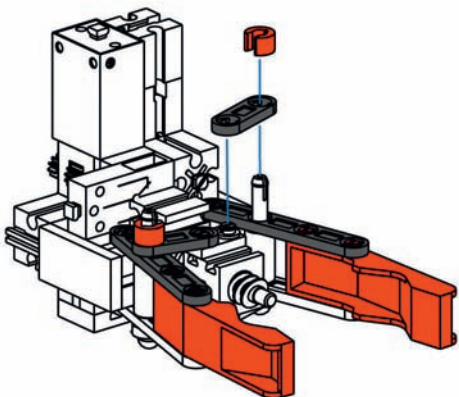
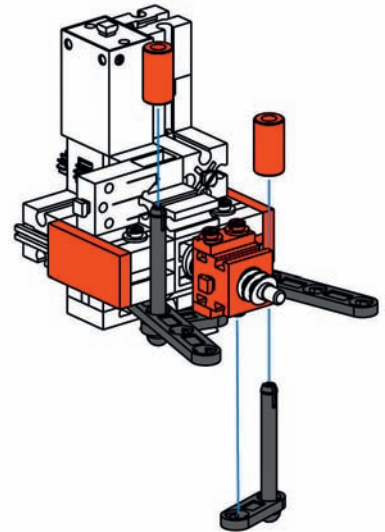

- 16**
- 2x [orange Technic beam 2x5]
 - 2x [orange Technic pin 15]
 - 2x [grey Technic beam 45]
 - 2x [orange Technic pin]

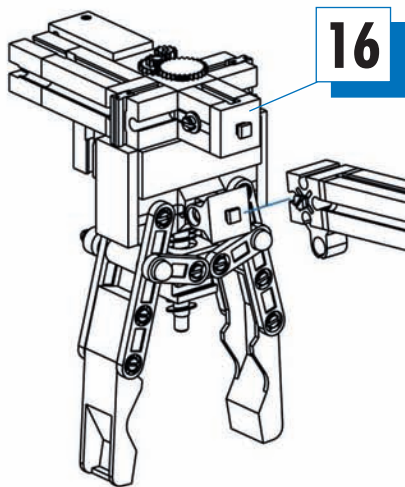

16

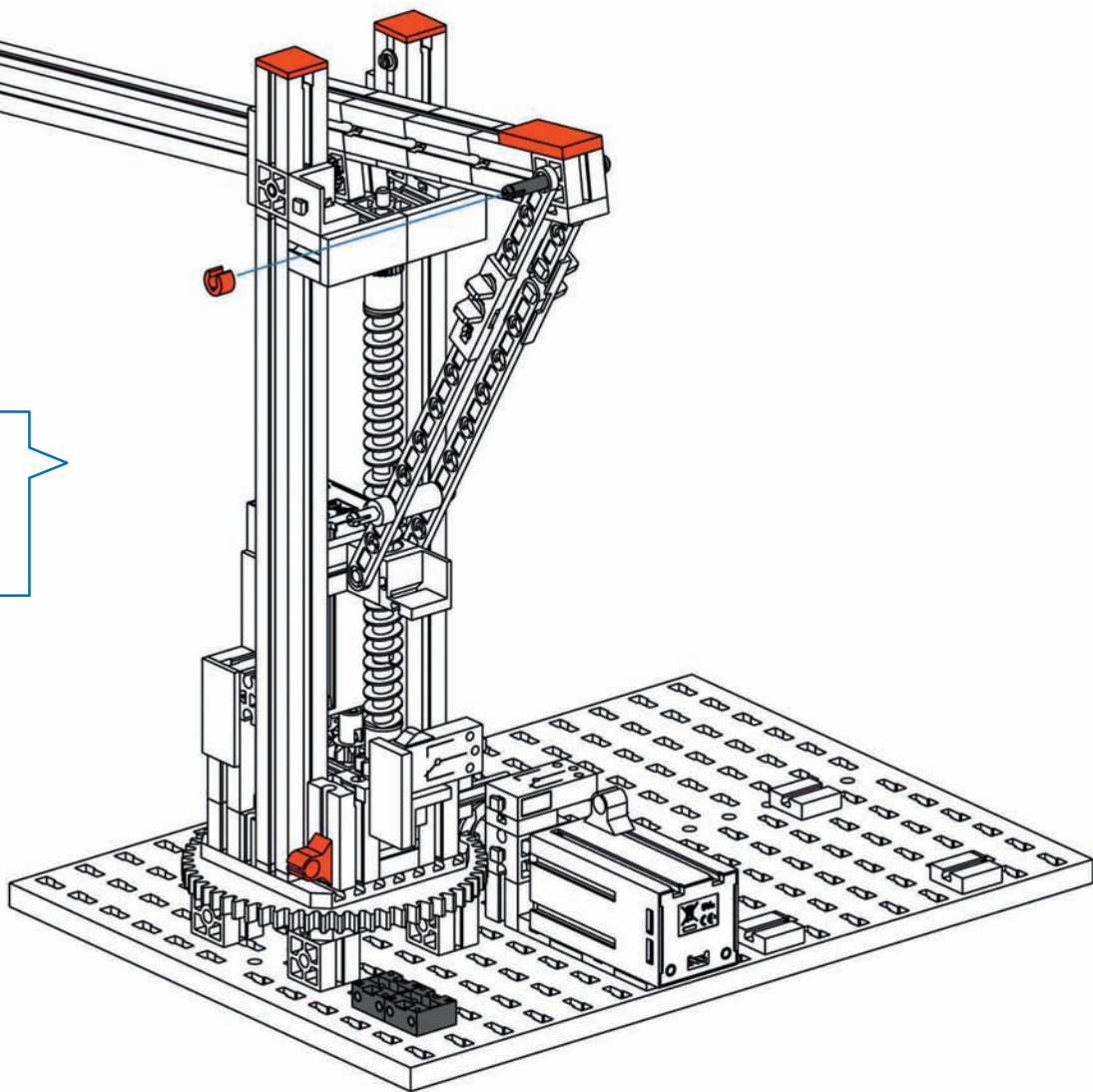
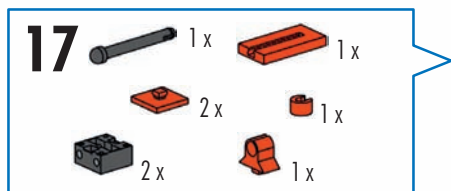

- ROBO TX Controller (Art.-Nr. 500 995) nicht im Baukasten enthalten
- ROBO TX Controller (Art.-Nr. 500 995) not included in the modular kit
- ROBO TX Controller (Art.-Nr. 500 995) n'est pas contenue dans le kit
- ROBO TX Controller (Art.-Nr. 500 995) niet in de bouwdoos opgenomen
- ROBO TX Controller (Art.-Nr. 500 995) no está incluido en el conjunto
- ROBO TX Controller (Art.-Nr. 500 995) não contido no sistema de construção por blocos
- ROBO TX Controller (Art.-Nr. 500 995) non incluso nella scatola di montaggio
- ROBO TX Controller (Art.-Nr. 500 995) не входит в комплект конструктора
- ROBO TX Controller (Art.-Nr. 500 995) 不包含在组件

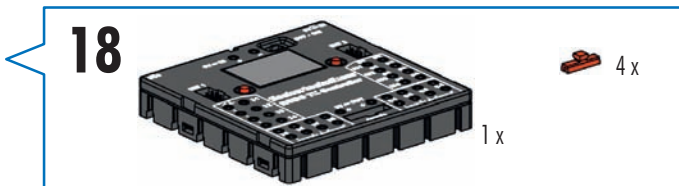
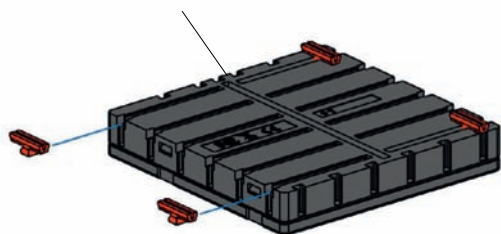

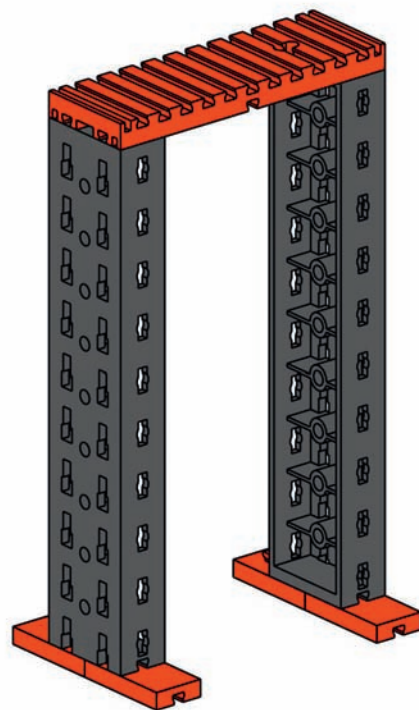
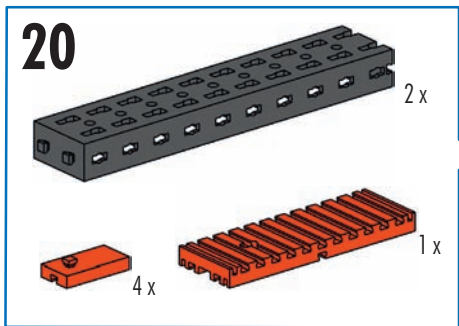
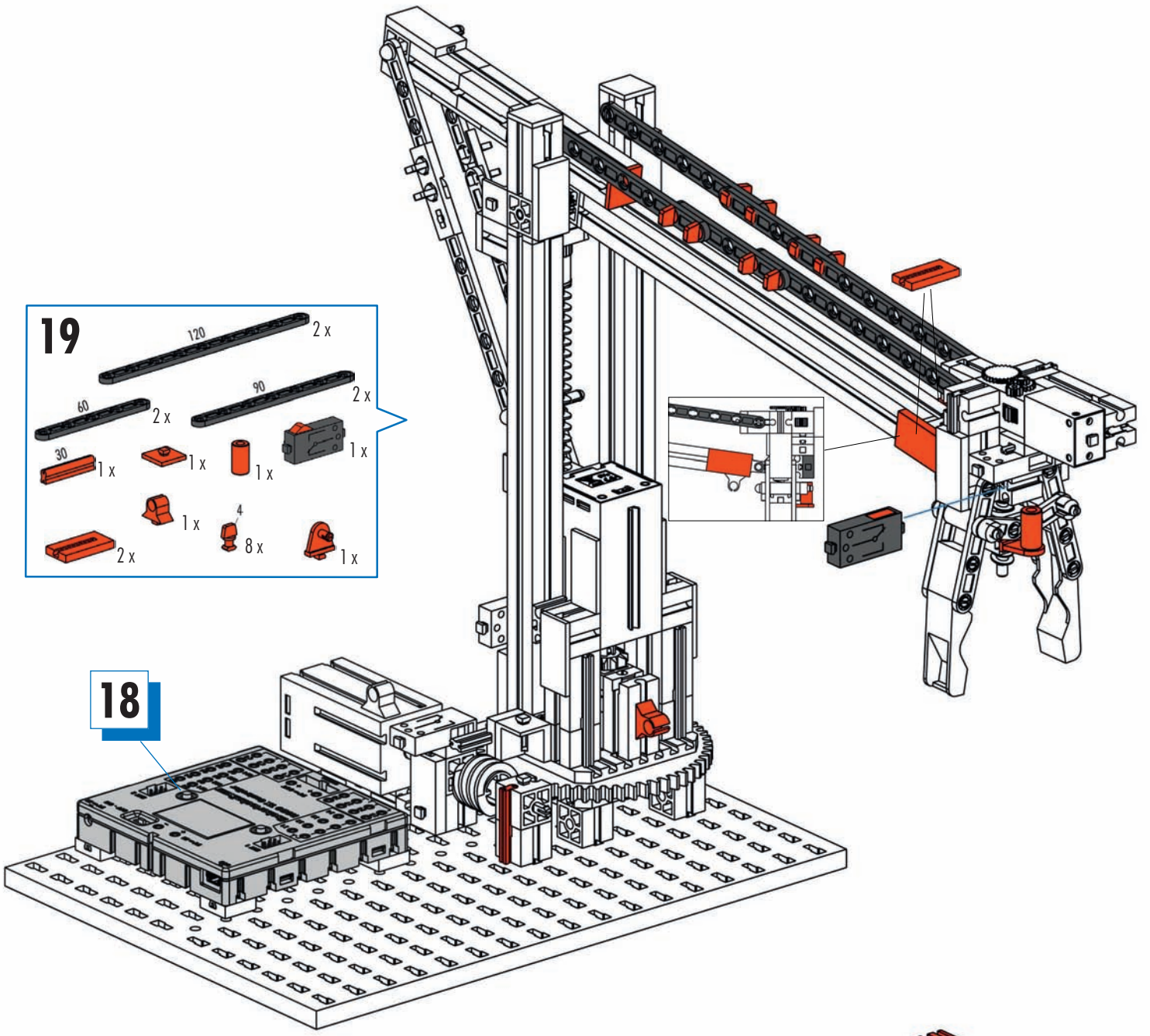

21

4x 4x 30 2x

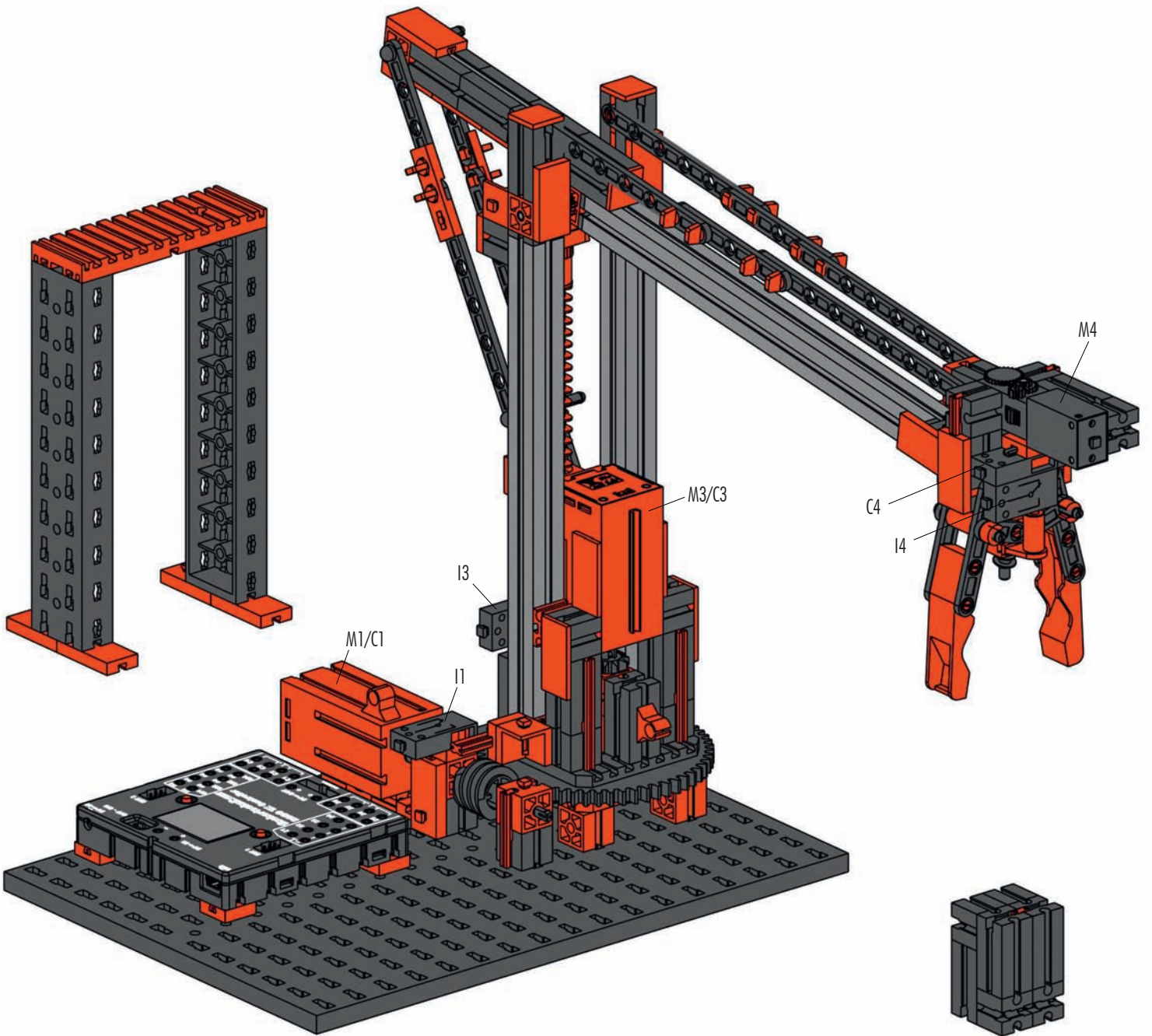
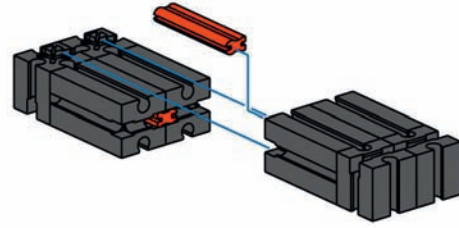

Schaltplan
Circuit diagram
Plan électrique

Schakelschema
Diagrama de circuitos
Plano elétrico de ligação

Schema elettrico
Схема подключения
电路图

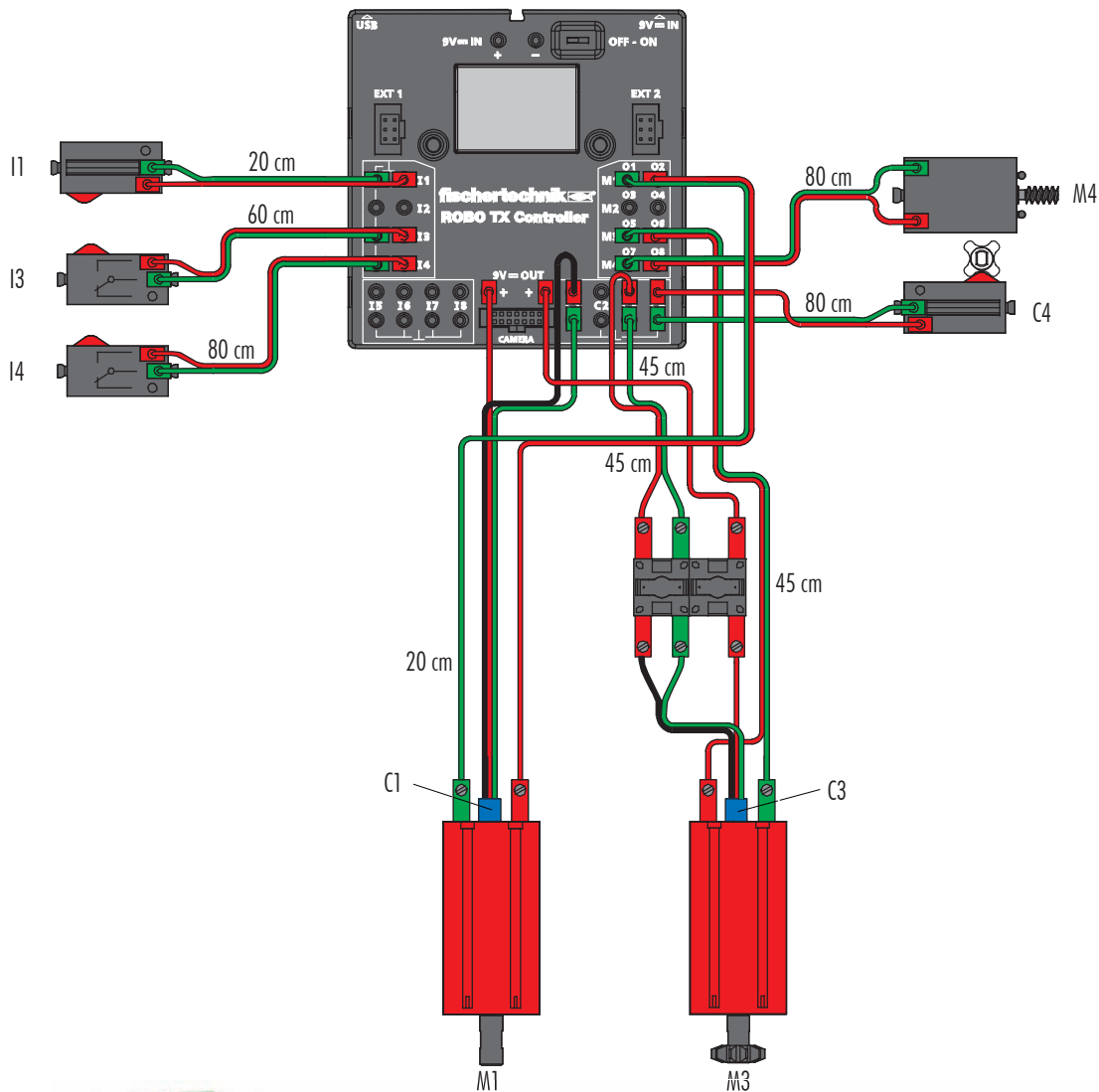

- Informationen zur Programmierung des Modells: Siehe didaktisches Begleitmaterial.
- Information on programming model: See related instructional material.
- Informations concernant la programmation de la maquette : voir le matériel d'accompagnement didactique.
- Informatie over de programmering van het model: Zie het didactisch begeleidend materiaal.
- Informaciones sobre la programación del modelo: Véase material didáctico.
- Informações sobre a programação do modelo: ver o material didático de acompanhamento.
- Informazioni sulla programmazione del modello: vedi materiale didattico.
- Информация о программировании модели: смотрите обучающий сопроводительный материал на CD.
- 有关该模型编程的信息：见 CD 光盘上的指导性说明资料。

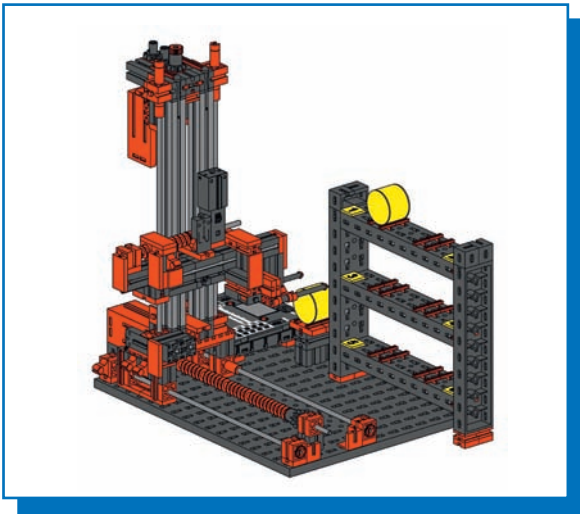

Hochregal
High bay storage rack
Rayonnage haut

Stellingmagazijn
Almacén elevado
Depósito de prateleira
alta

Magazzino alto
 Высотный
 стеллажный склад
 高货架仓库

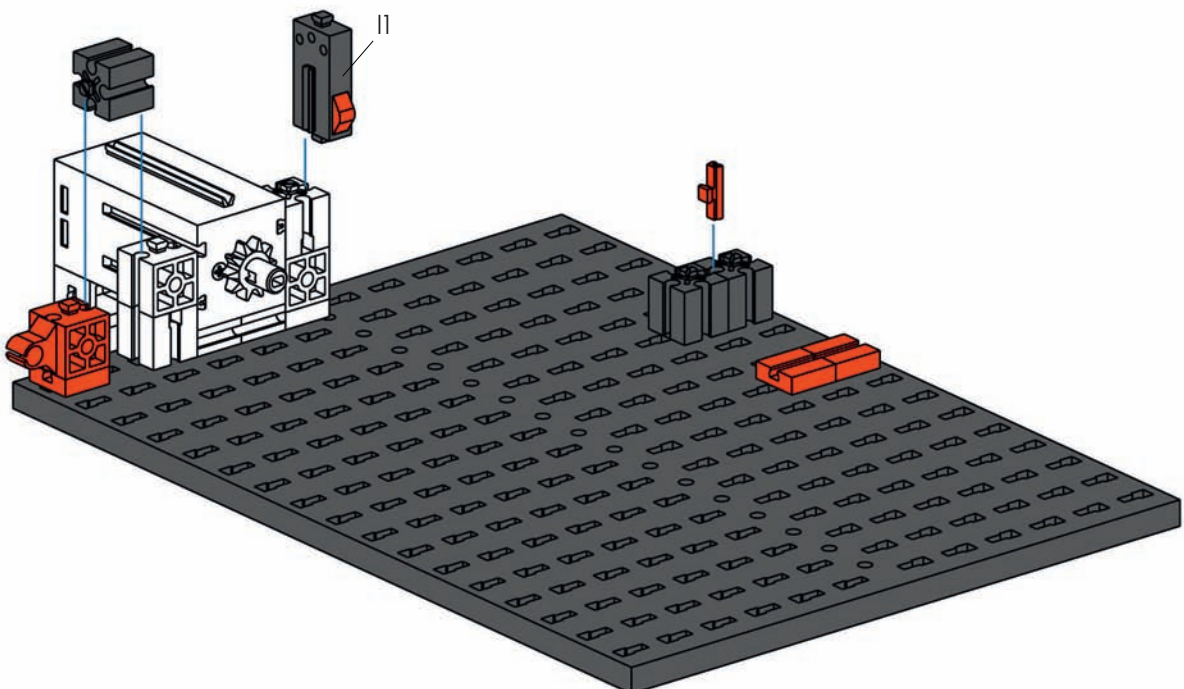
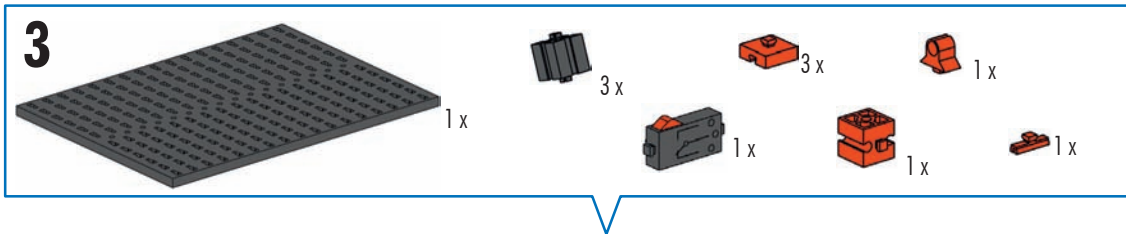
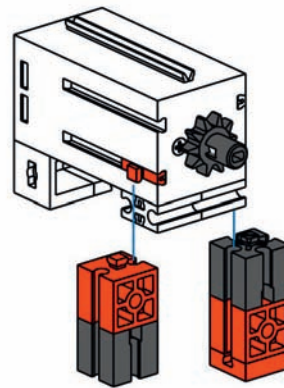
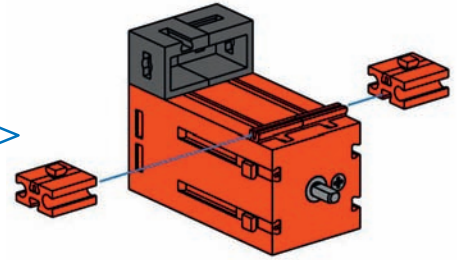
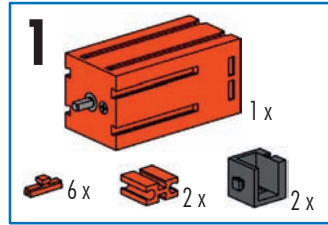

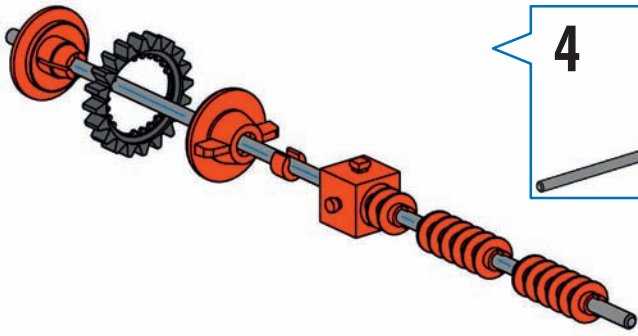

4

- 1 x [Red bush]
- 1 x [Grey axle, 260]
- 1 x [Red gear]
- 1 x [Red bush]
- 3 x [Red spring]
- 1 x [Red cube]
- 1 x [Red bush]

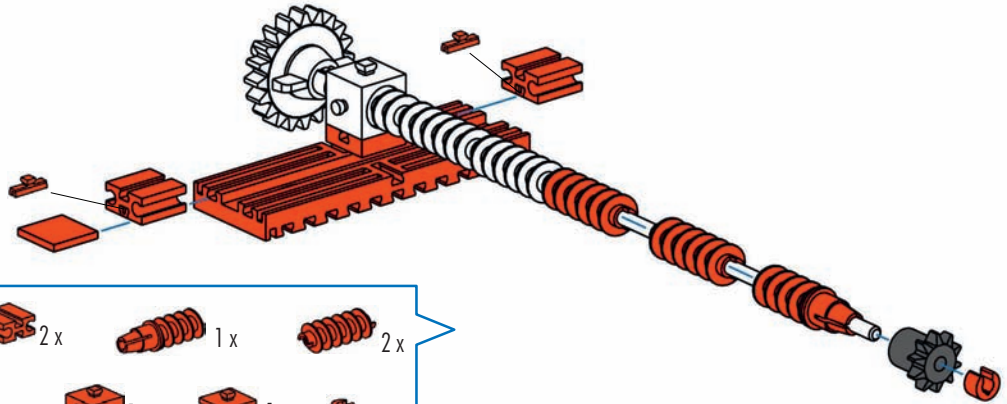

5

- 1 x [Red Technic beam, 11 holes]
- 2 x [Red Technic beam, 2 holes]
- 1 x [Red spring]
- 2 x [Red spring]
- 2 x [Red Technic pin]
- 1 x [Grey Technic bush]
- 1 x [Red Technic bush]
- 1 x [Red Technic bush]
- 1 x [Red Technic bush]

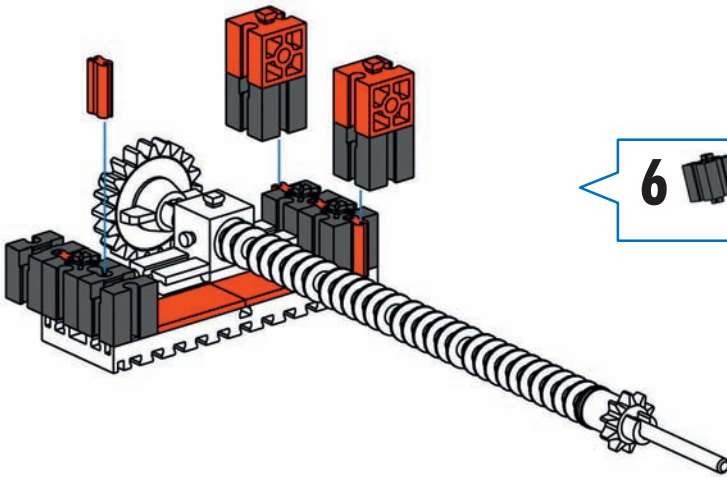

6







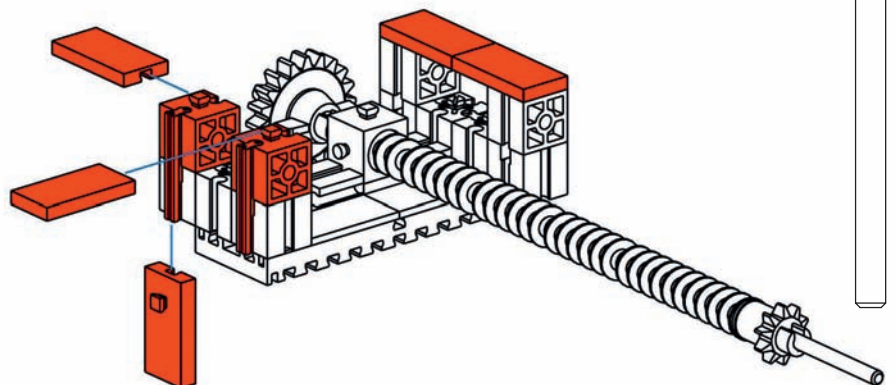

- 3 x [Grey Technic bush]
- 4 x [Grey Technic bush]
- 2 x [Red Technic bush]
- 2 x [Red Technic beam, 2 holes]
- 5 x [Red Technic beam, 15 holes]

7







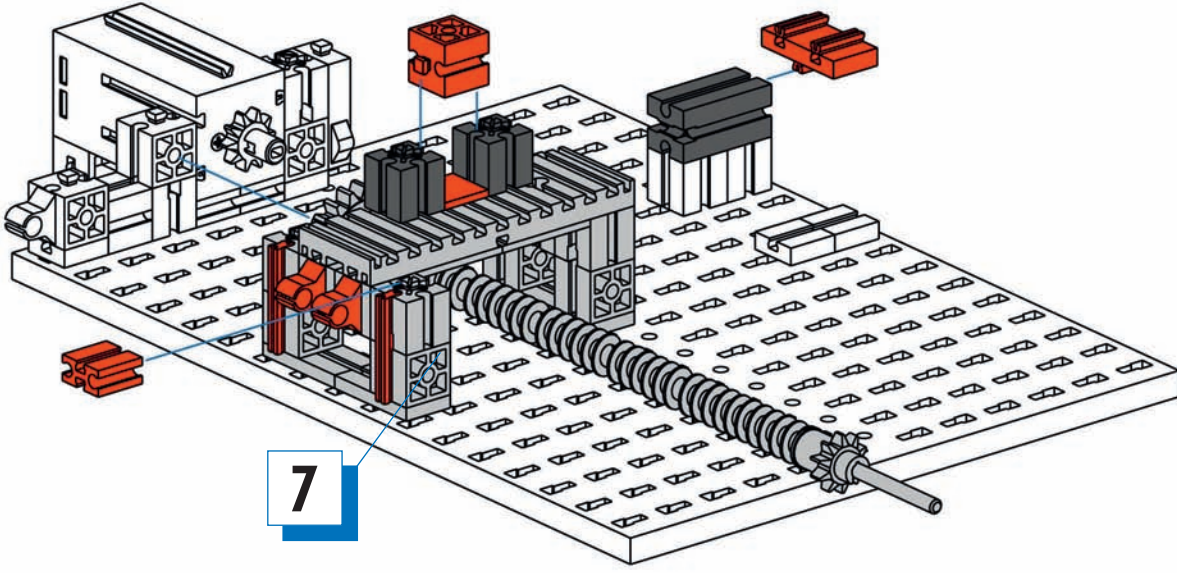

- 2 x [Red Technic bush]
- 4 x [Red Technic beam, 2 holes]
- 2 x [Red Technic beam, 30 holes]
- 1 x [Red Technic bush]

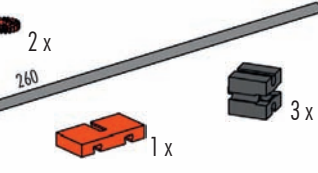

260 mm

- 8**  1x  2x  1x  1x  1x  1x  2x  3x  2x



- 9**  1x  2x  2x  4x  3x  1x  3x  1x  3x

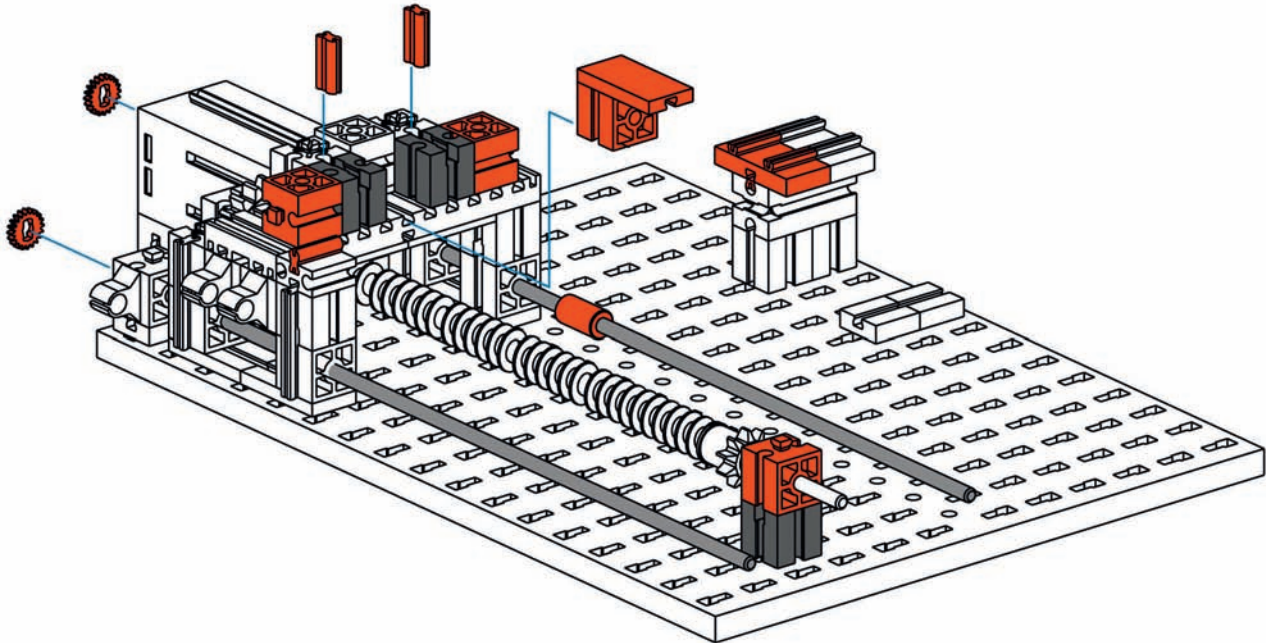

10

- 1 x (orange bush)
- 1 x (orange bush)
- 1 x (grey axle, 260)
- 1 x (orange bush)
- 2 x (orange bush)
- 1 x (orange spring)
- 5 x (orange spring)

15 mm

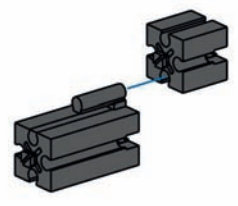
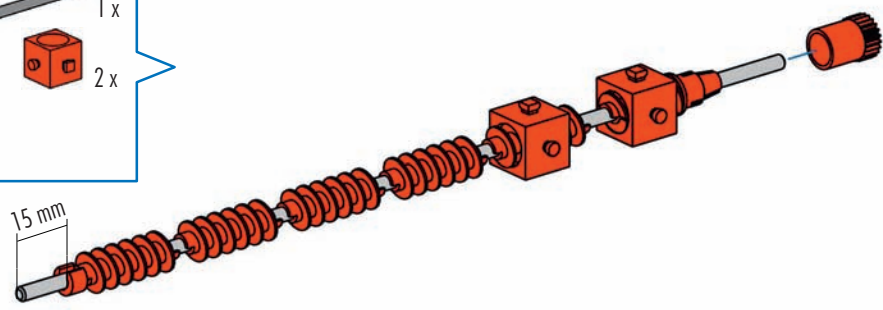

11

- 1 x (grey Technic beam)
- 1 x (grey Technic beam)
- 1 x (grey Technic pin)

12

- 4 x (grey Technic beam)
- 1 x (grey Technic beam)
- 2 x (grey Technic pin)

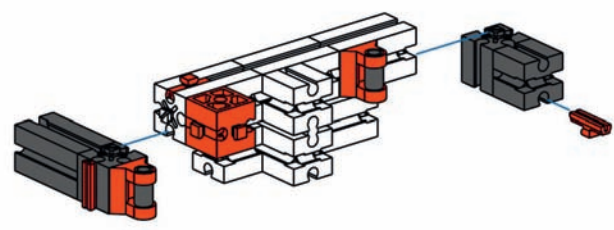
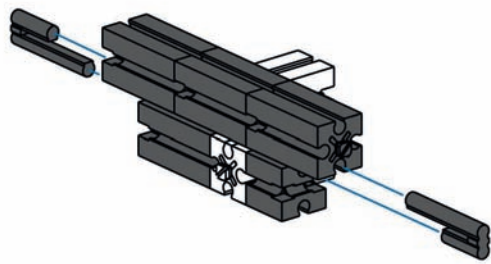

13

- 1 x (grey Technic beam)
- 3 x (grey Technic beam)
- 2 x (orange bush)
- 4 x (orange bush)
- 1 x (orange bush)

260 mm

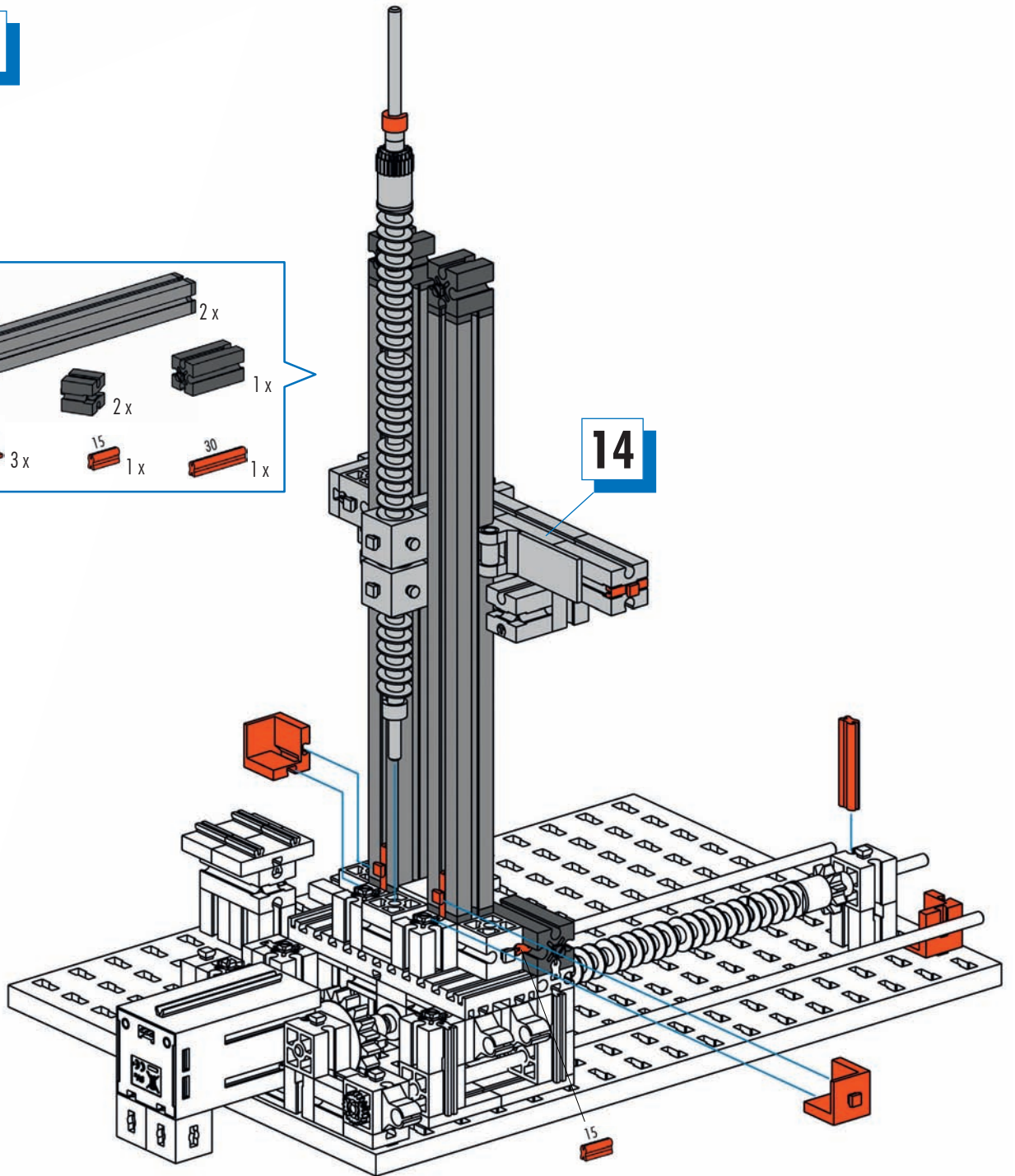
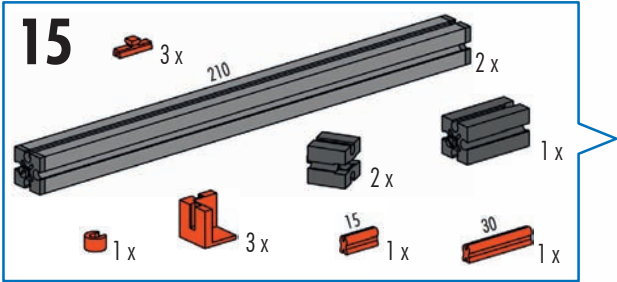
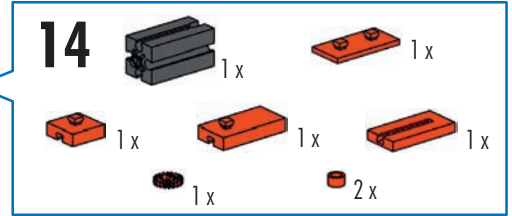
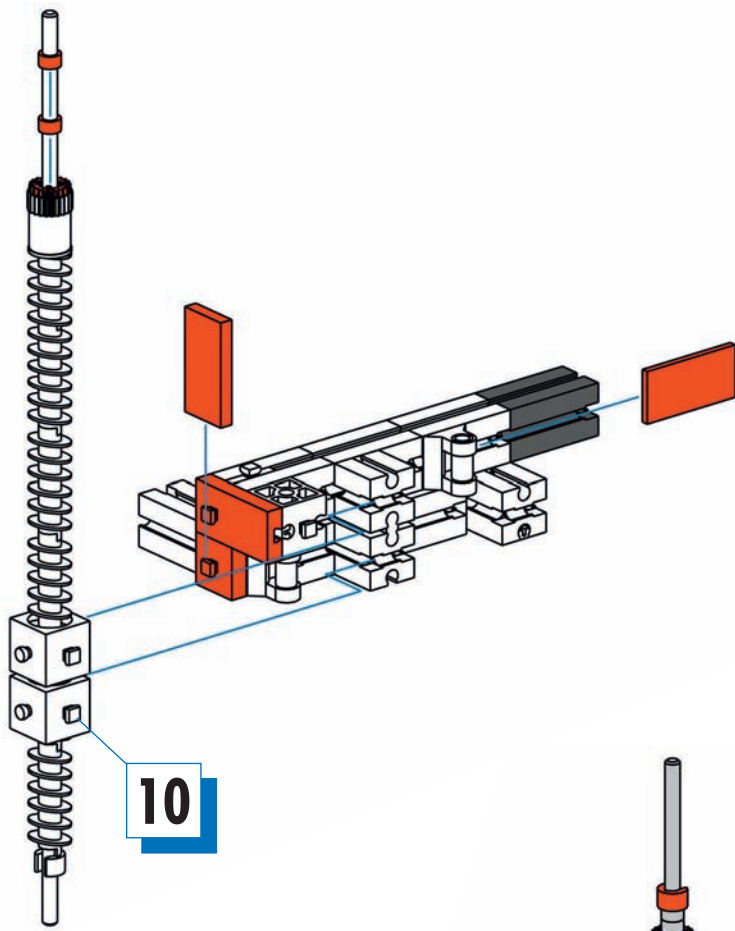

16

- 1x [Grey 2x3 Technic Brick]
- 3x [Red 2x3 Technic Brick]
- 1x [Grey Technic Pin]
- 1x [Grey Technic Bush]
- 2x [Red 1x Technic Pin]

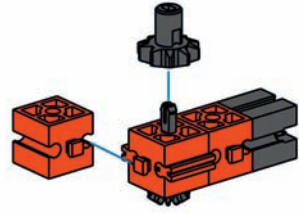

17

- 2x [Grey 2x3 Technic Brick]
- 2x [Grey 2x3 Technic Brick]
- 1x [Red 2x3 Technic Brick]
- 1x [Grey Technic Pin]
- 1x [Red 1x Technic Pin]
- 1x [Red 1x Technic Pin]

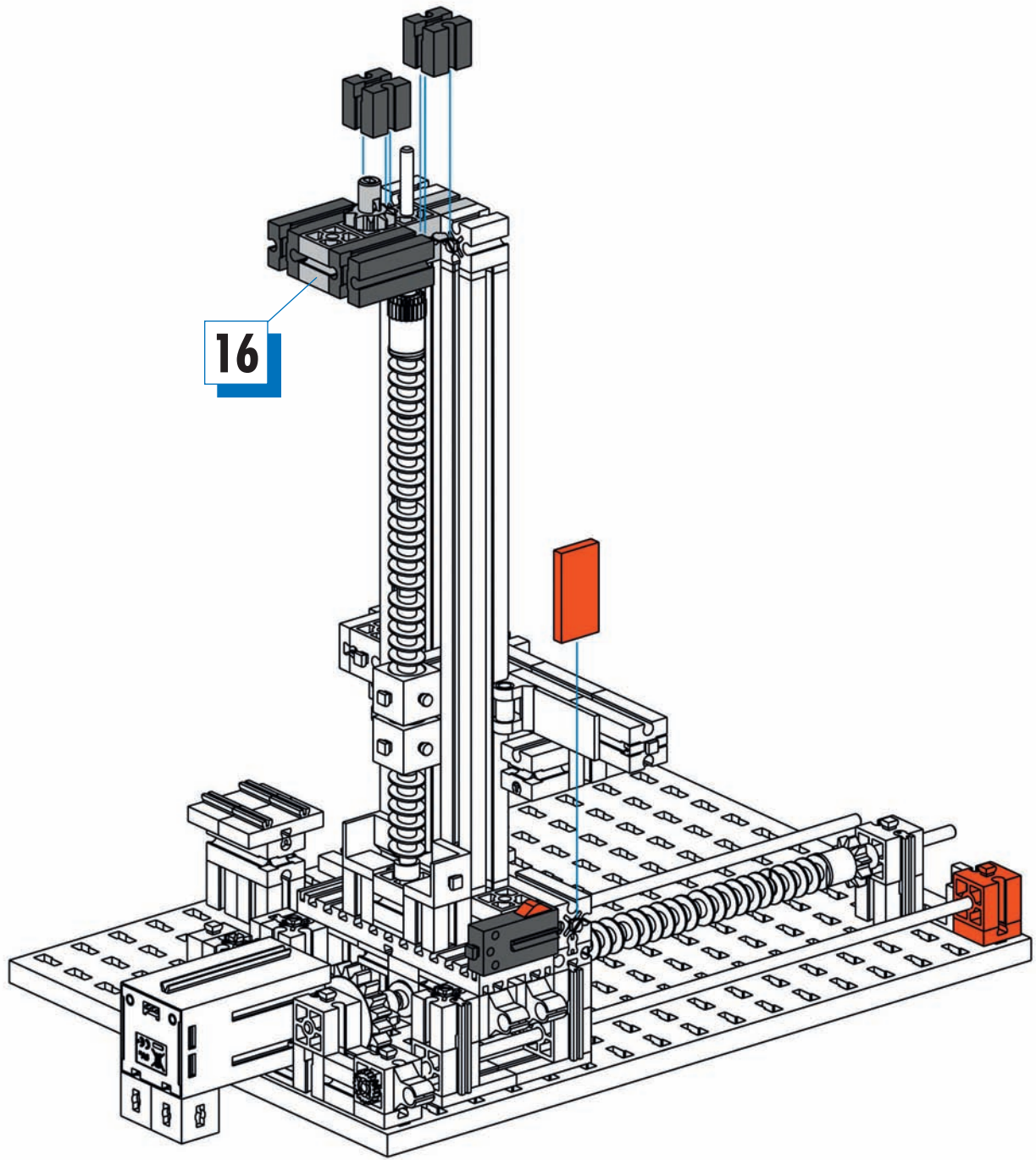

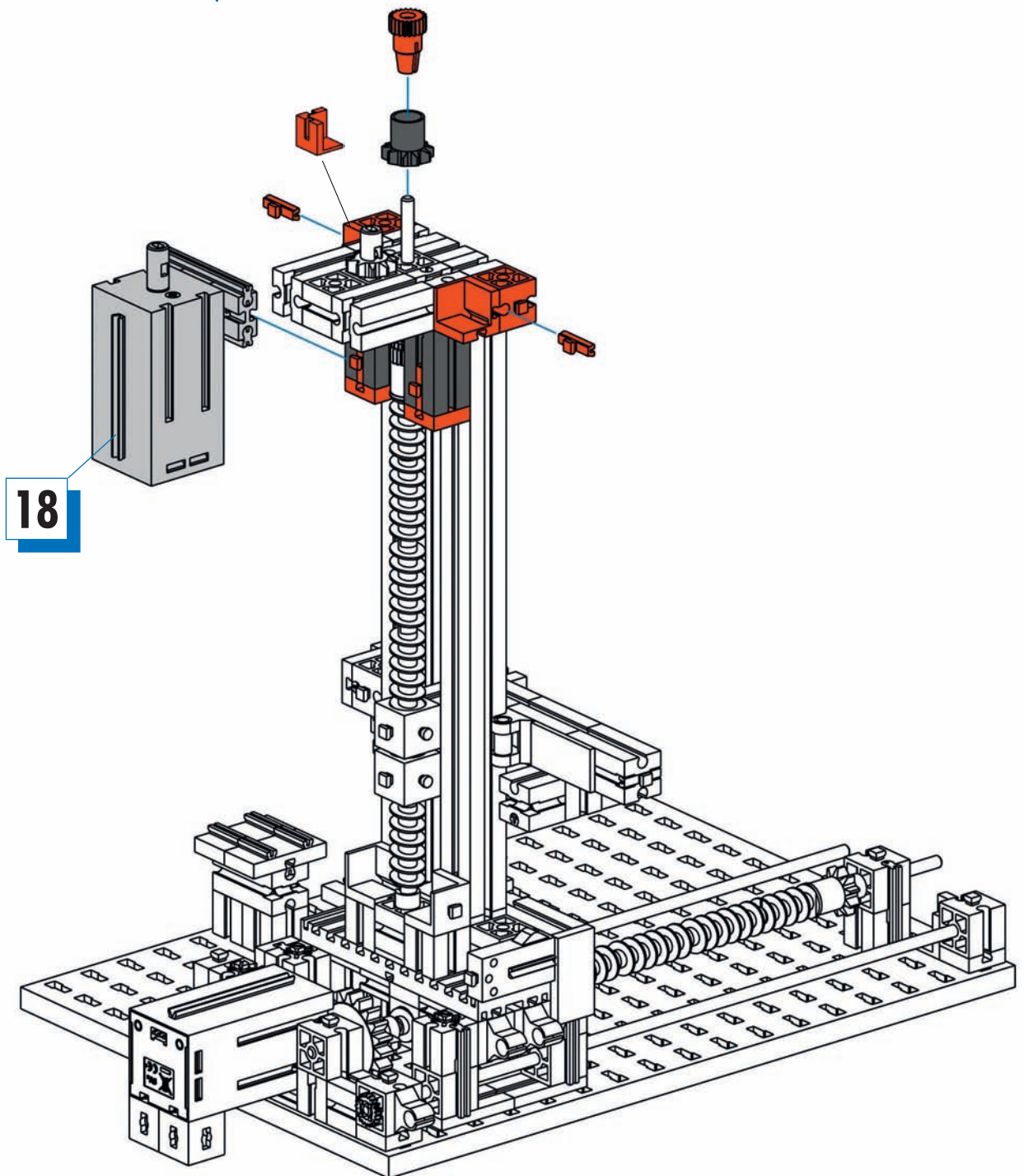
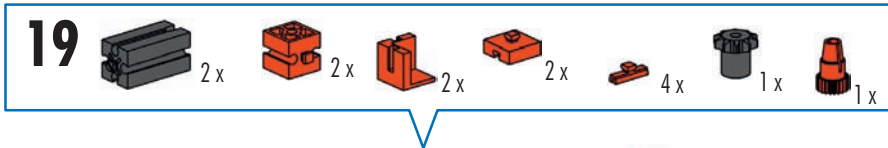
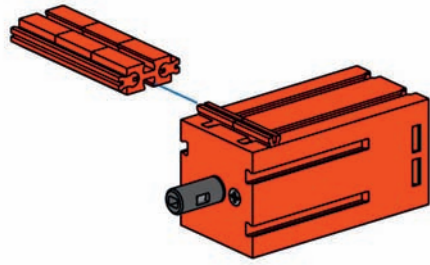
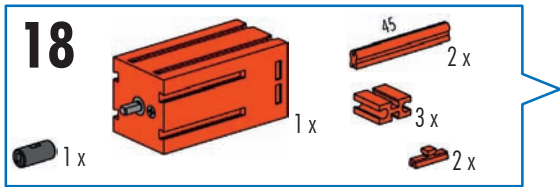

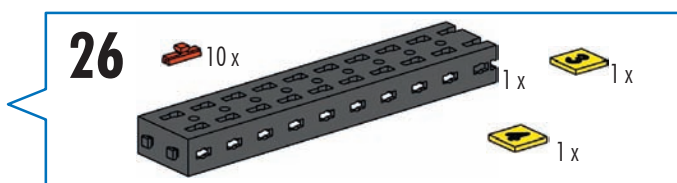
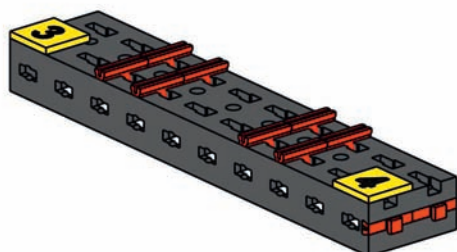
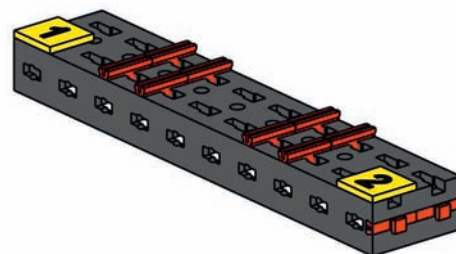
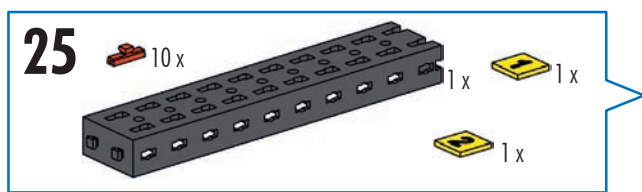
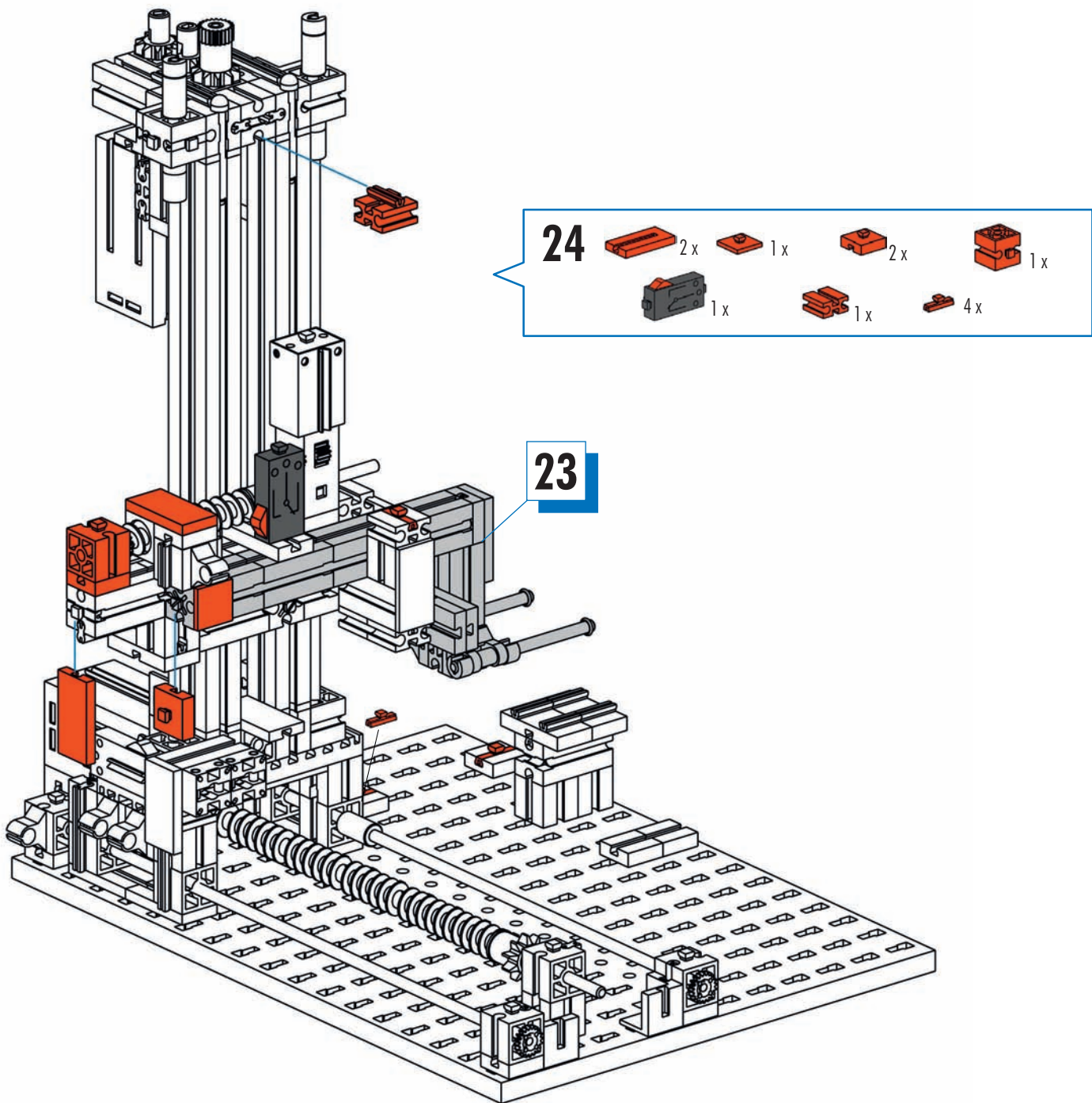

27

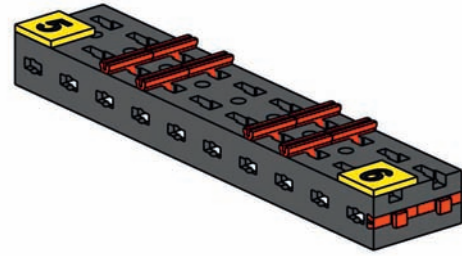
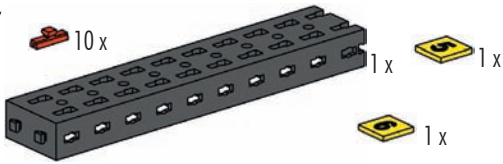

- ROBO TX Controller (Art.-Nr. 500 995) nicht im Baukasten enthalten
- ROBO TX Controller (Art.-Nr. 500 995) not included in the modular kit
- ROBO TX Controller (Art.-Nr. 500 995) n'est pas contenue dans le kit
- ROBO TX Controller (Art.-Nr. 500 995) niet in de bouwdoos opgenomen
- ROBO TX Controller (Art.-Nr. 500 995) no está incluido en el conjunto
- ROBO TX Controller (Art.-Nr. 500 995) não contido no sistema de construção por blocos
- ROBO TX Controller (Art.-Nr. 500 995) non incluso nella scatola di montaggio
- ROBO TX Controller (Art.-Nr. 500 995) не входит в комплект конструктора
- ROBO TX Controller (Art.-Nr. 500 995) 不包含在组件

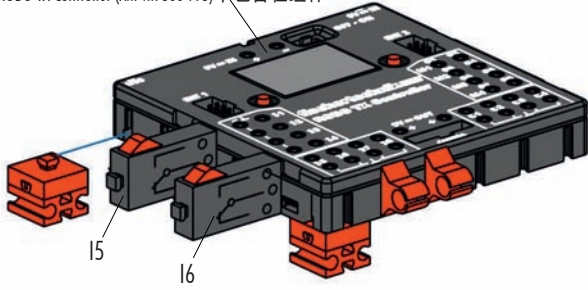

28

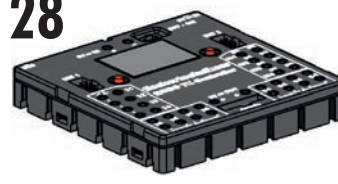
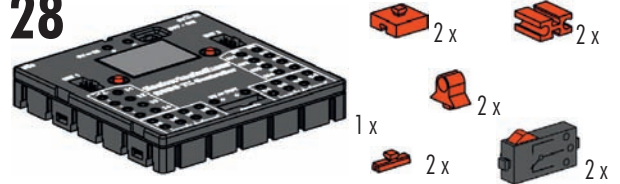

29

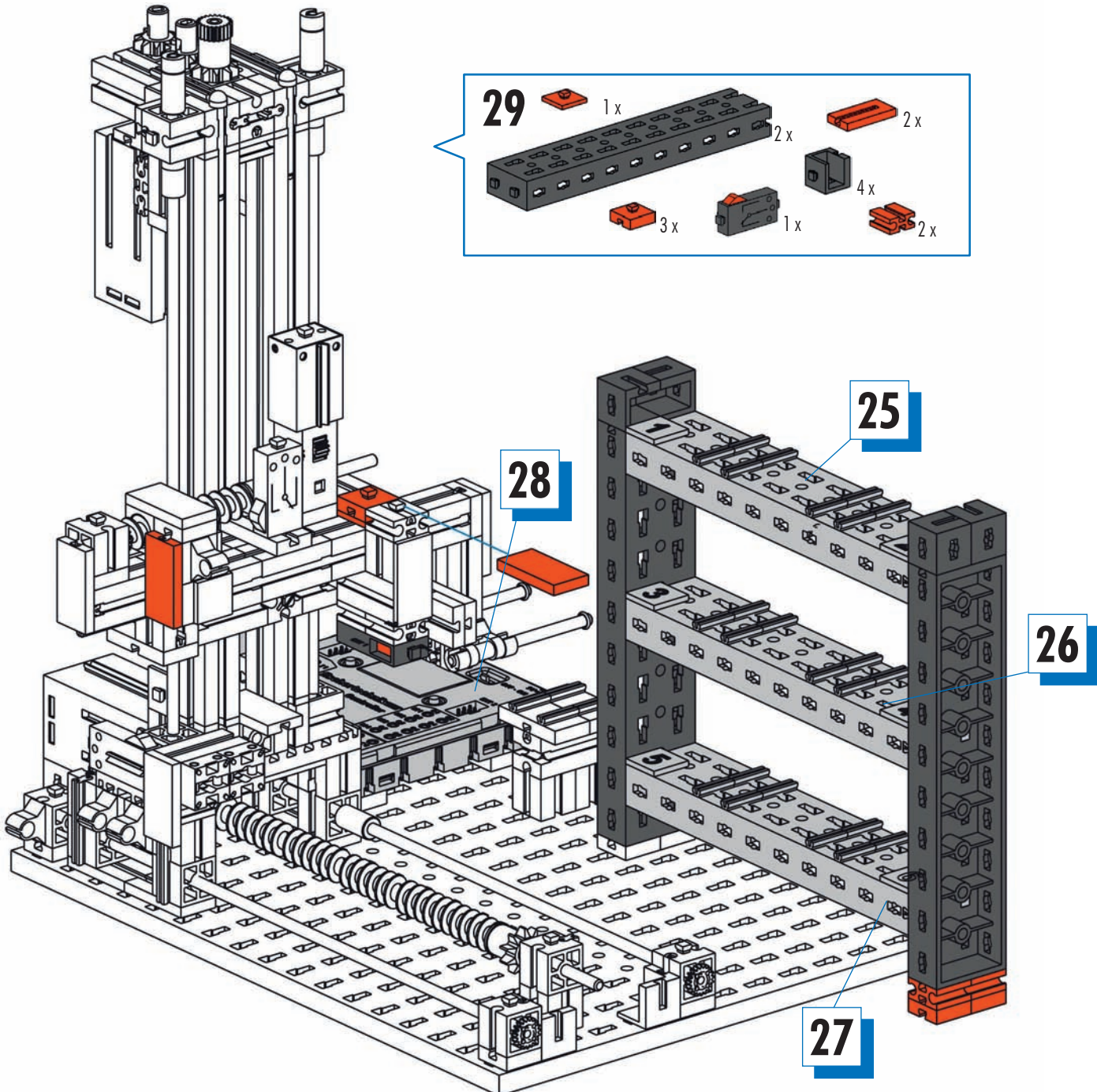
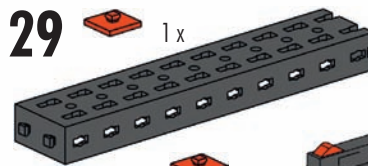
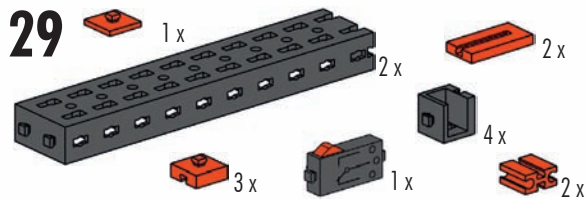

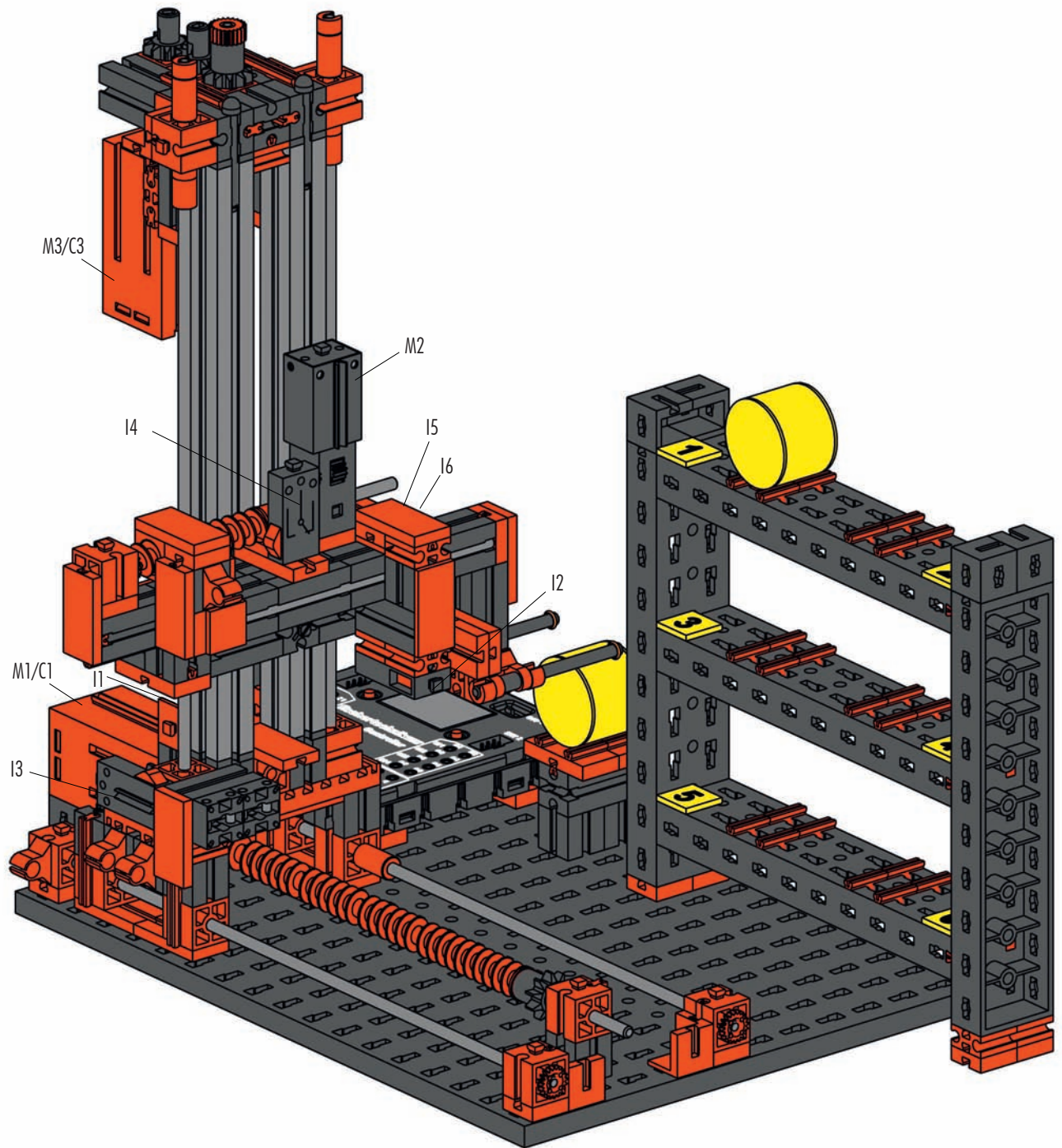

Schaltplan
Circuit diagram
Plan électrique

Schakelschema
Diagrama de circuitos
Plano elétrico de ligação

Schema elettrico
Схема подключения
电路图

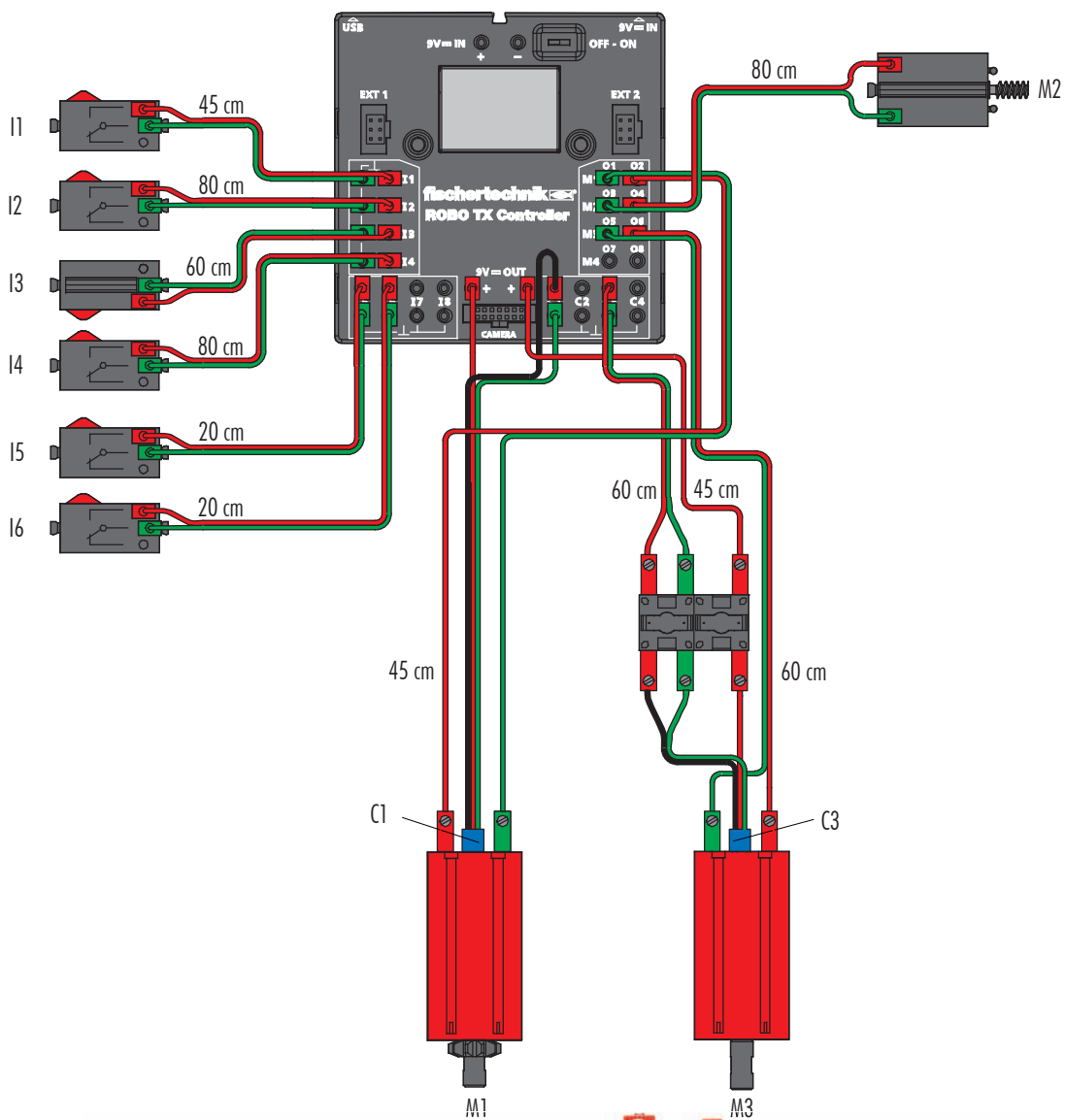

- Informationen zur Programmierung des Modells: Siehe didaktisches Begleitmaterial.
- Information on programming model: See related instructional material.
- Informations concernant la programmation de la maquette : voir le matériel d'accompagnement didactique.
- Informatie over de programmering van het model: Zie het didactisch begeleidend materiaal.
- Informaciones sobre la programación del modelo: Véase material didáctico.
- Informações sobre a programação do modelo: ver o material didático de acompanhamento.
- Informazioni sulla programmazione del modello: vedi materiale didattico.
- Информация о программировании модели: смотрите обучающий сопроводительный материал на CD.
- 有关该模型编程的信息：见 CD 光盘上的指导性说明资料。

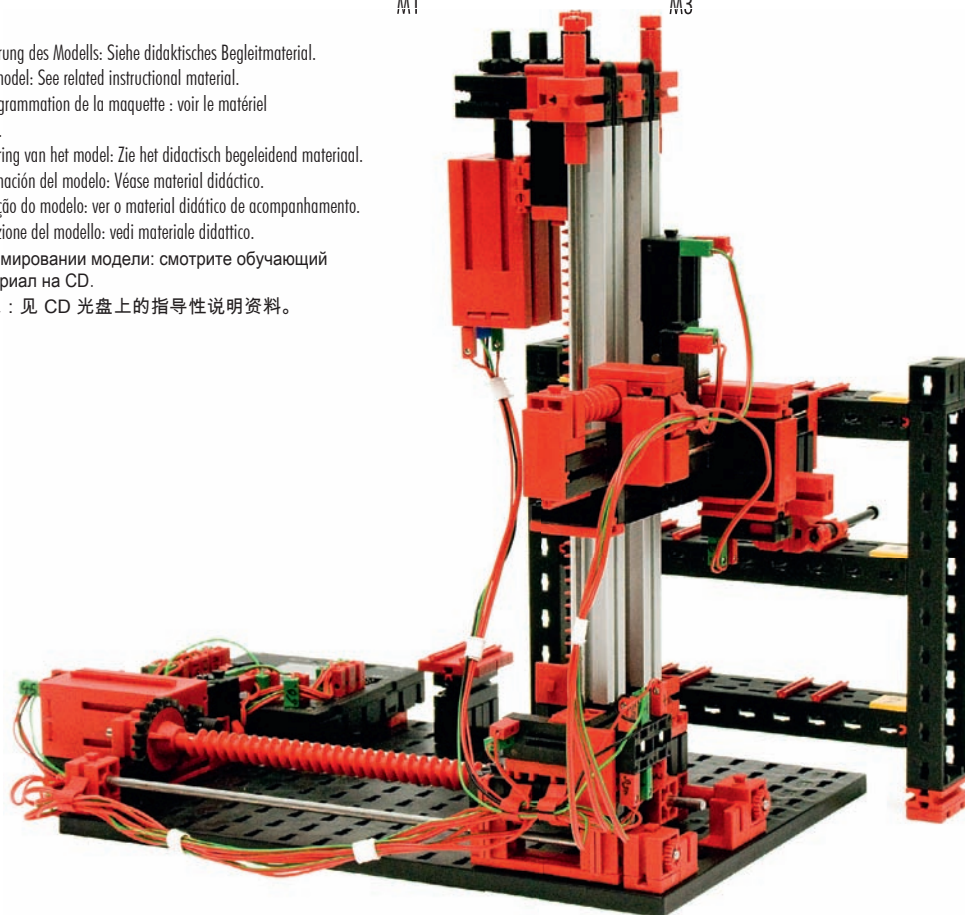

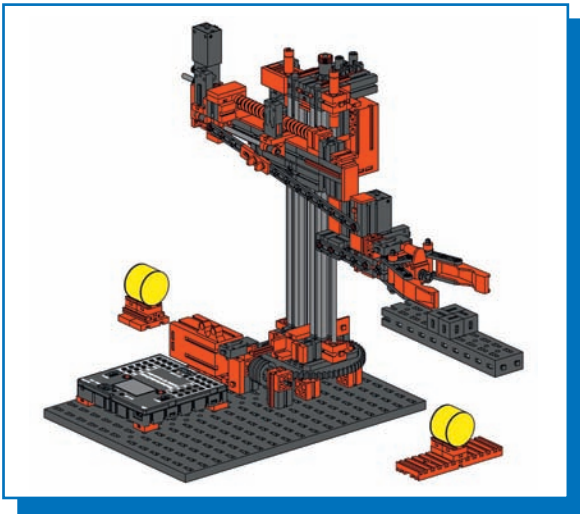

Schwenngreifer
Pivoting gripper
Grappin basculant

Zwenkgrijper
Pinza oscilante
Garras rotativas

Pinza orientabile
Поворотный захват
回转抓爪

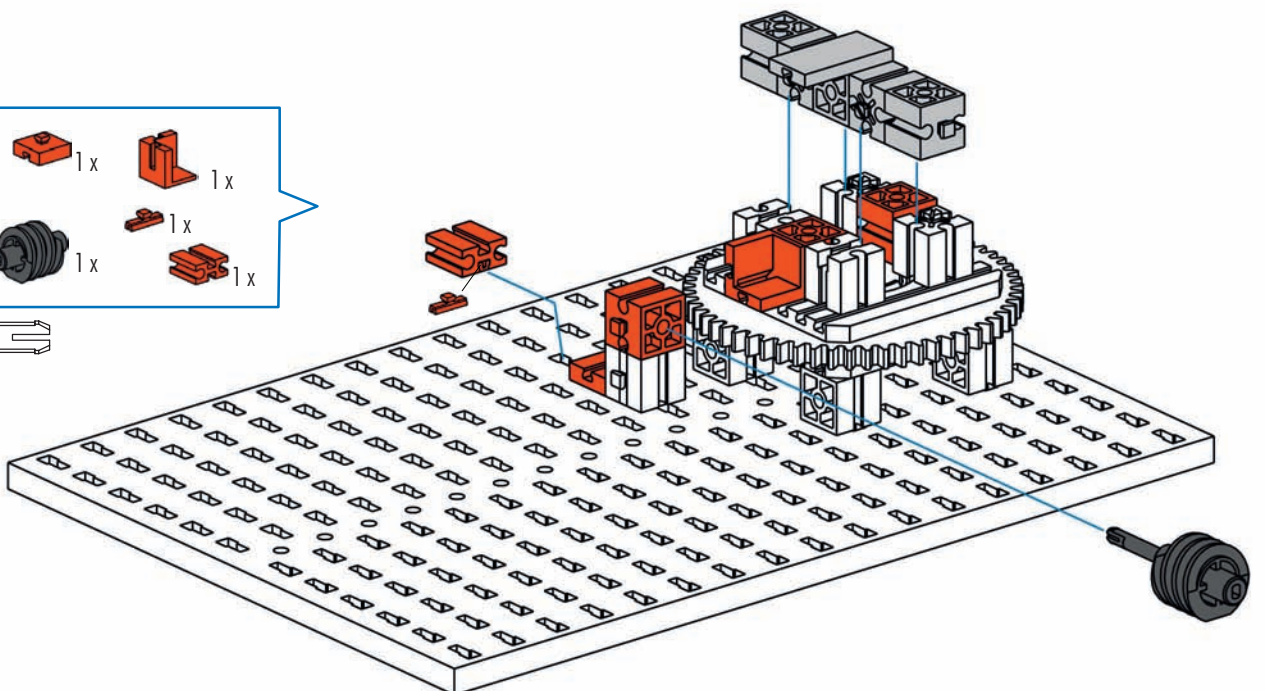
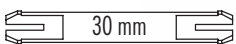
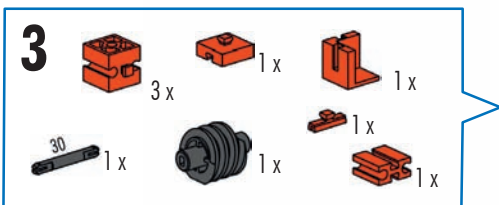
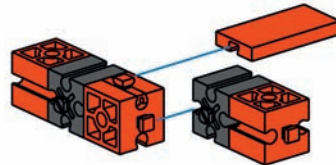
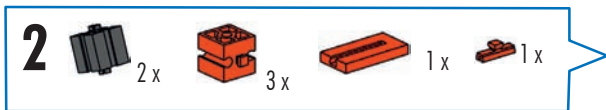
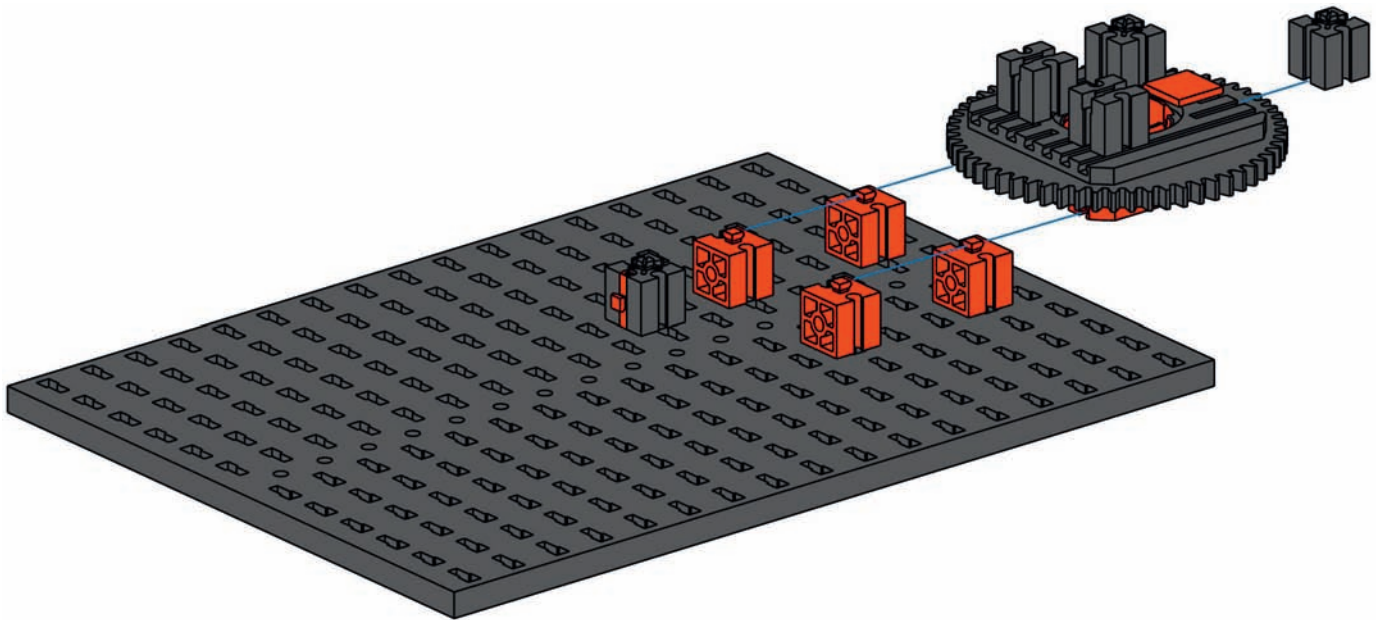
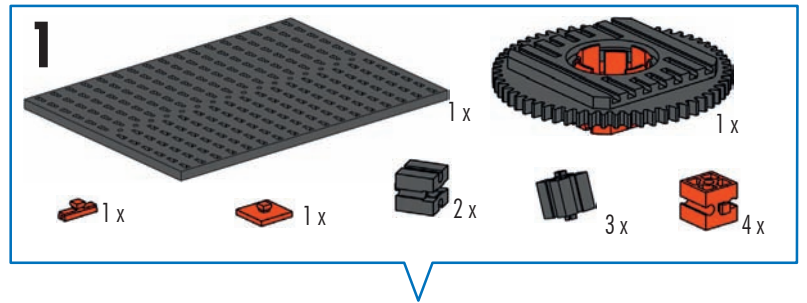

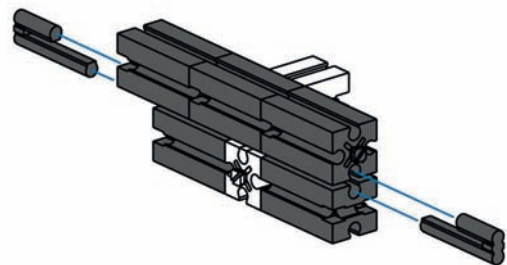
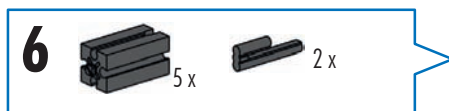
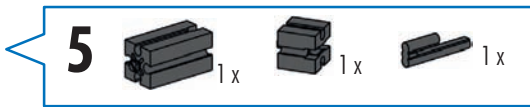
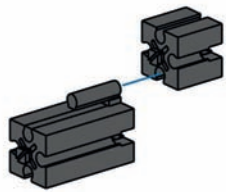
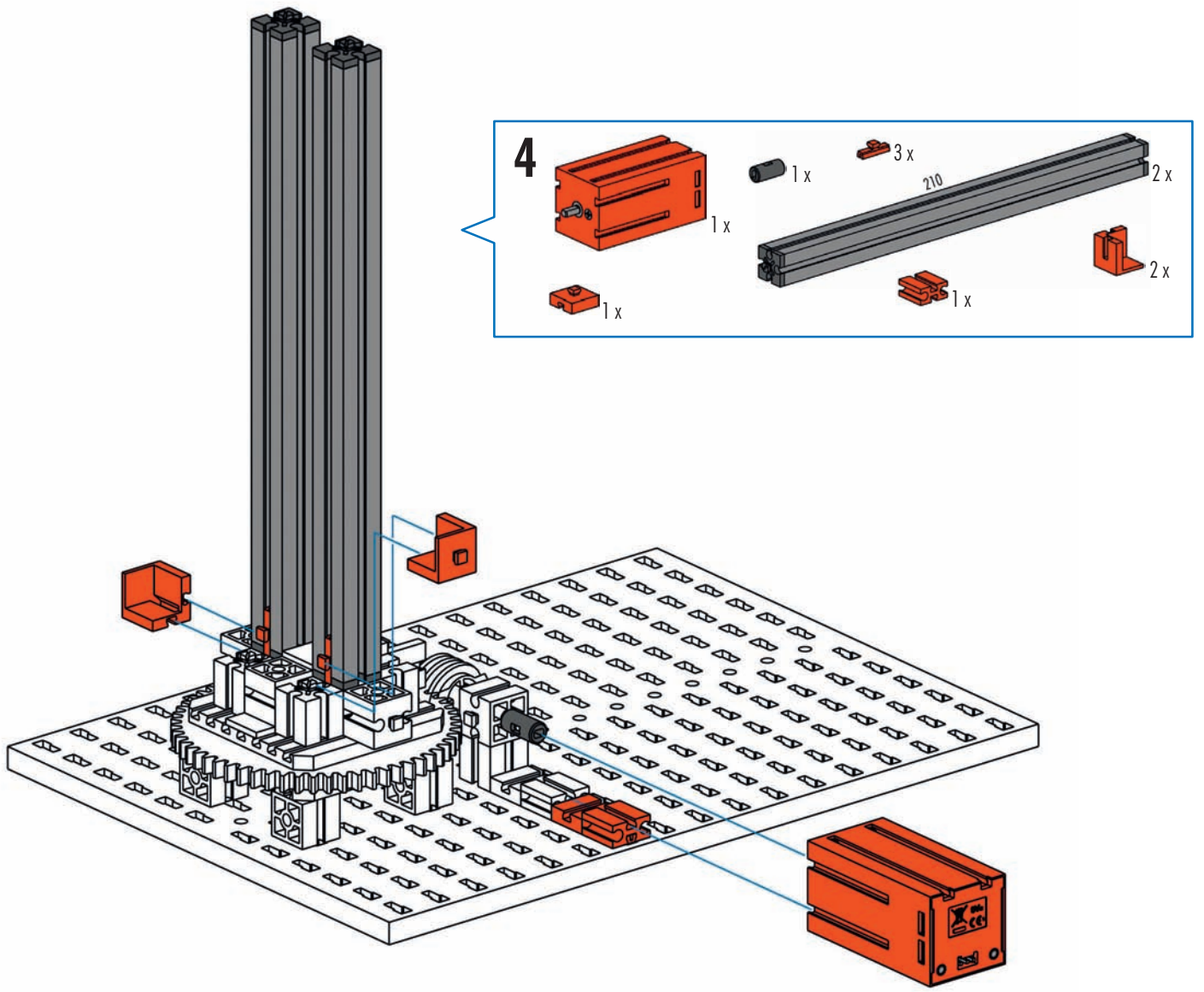

7

- 1 x [Red bush]
- 1 x [Red bush]
- 1 x [Grey axle, 260 mm]
- 1 x [Red bush]
- 1 x [Red bush]
- 5 x [Red spring]
- 2 x [Red bush]

15 mm

8

- 1 x [Grey axle]
- 1 x [Red bush]
- 2 x [Red bush]
- 1 x [Red bush]
- 1 x [Red bush]
- 1 x [Red bush]
- 1 x [Red bush]

8

6

260 mm

9

- 1 x [Grey axle]
- 4 x [Grey axle]
- 2 x [Red bush]
- 3 x [Red bush]
- 1 x [Red bush]
- 1 x [Red bush]
- 2 x [Red bush]

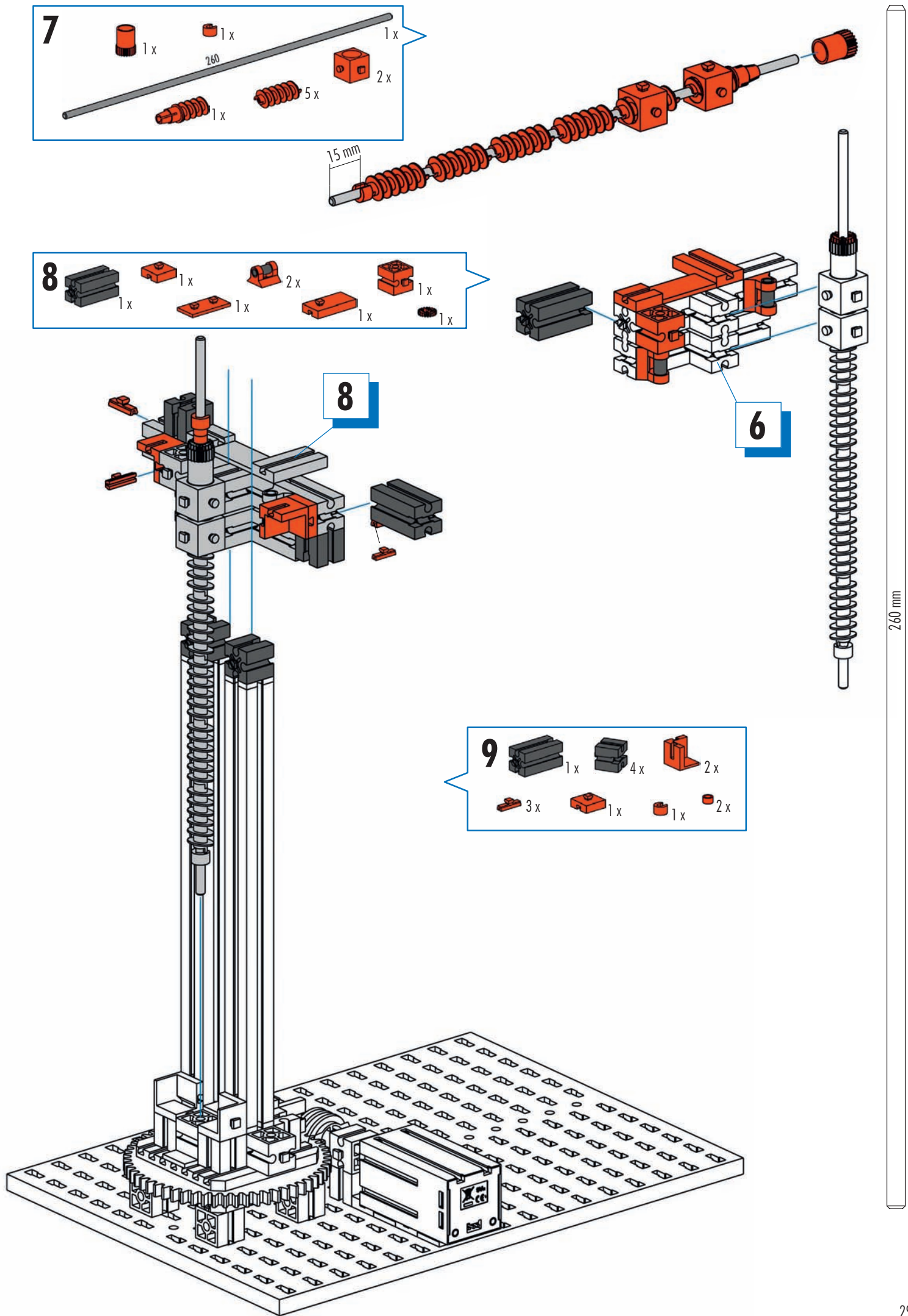

10



1x



3x



1x



1x



2x

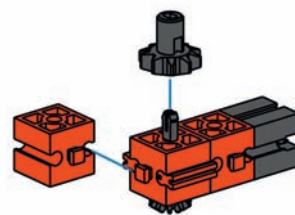

10

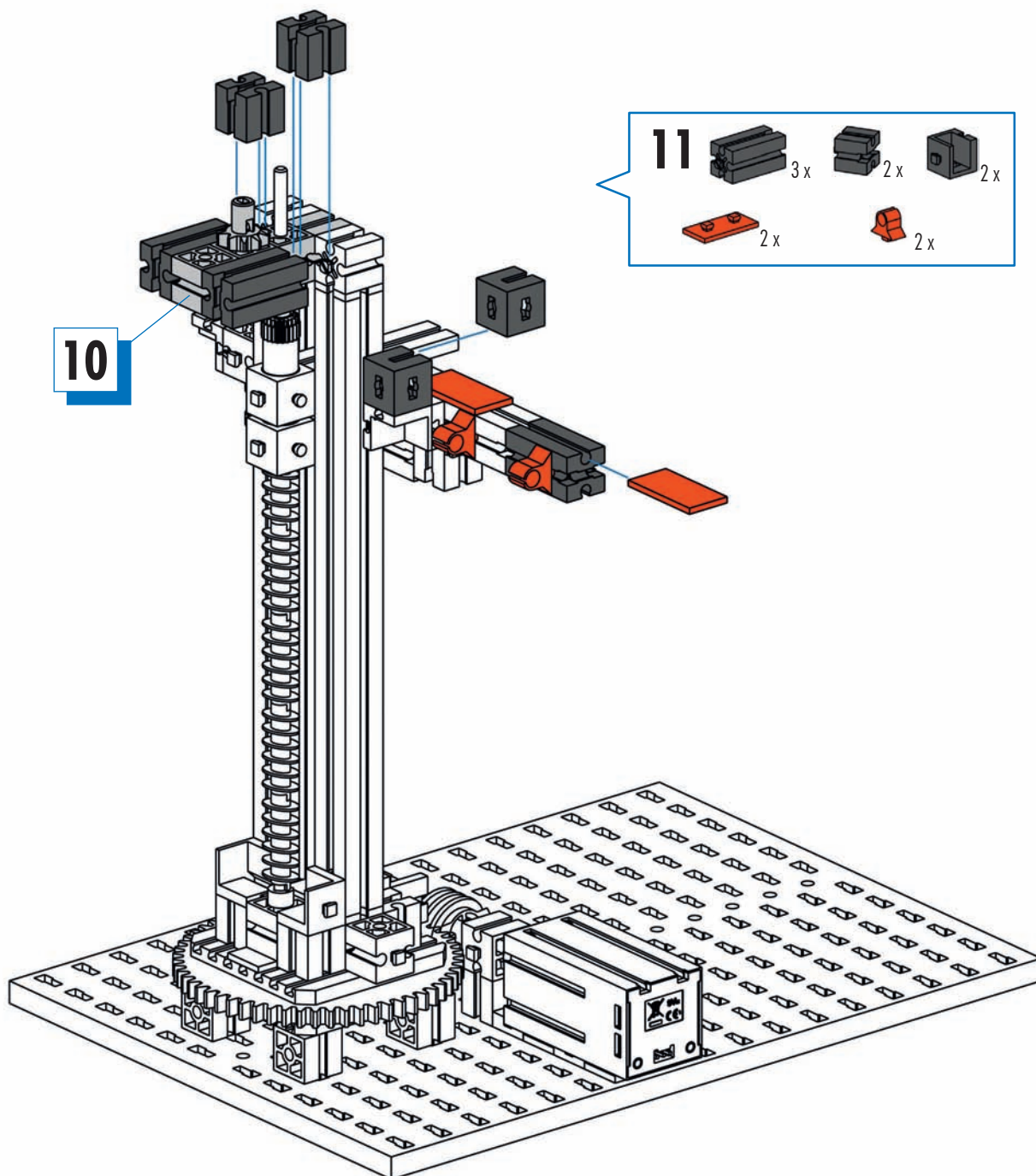

11



3x



2x



2x



2x



2x

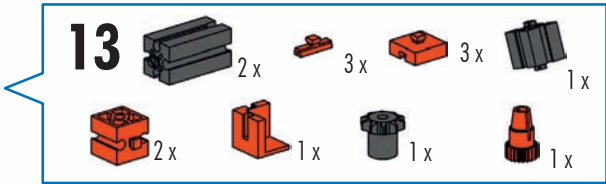
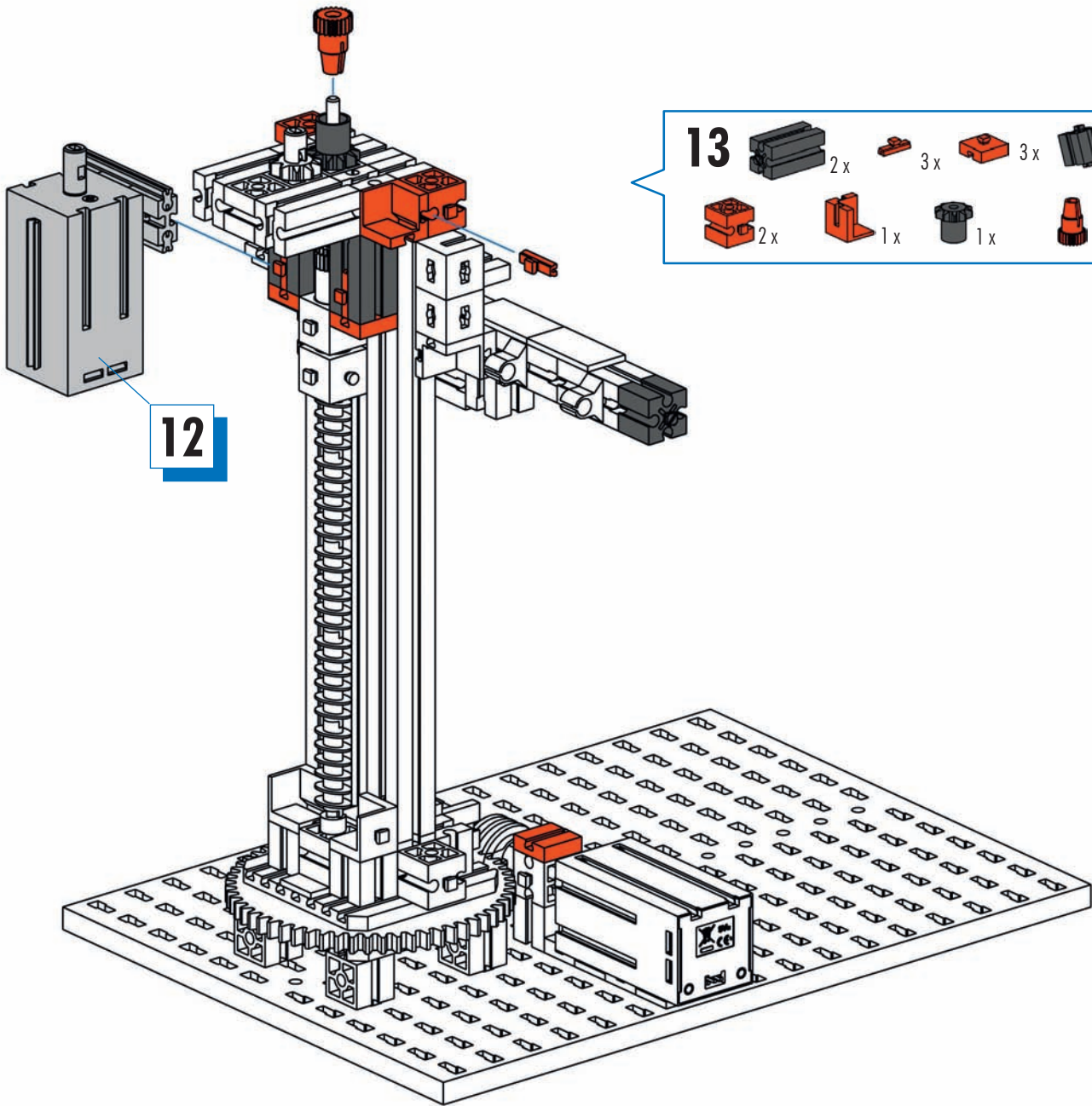
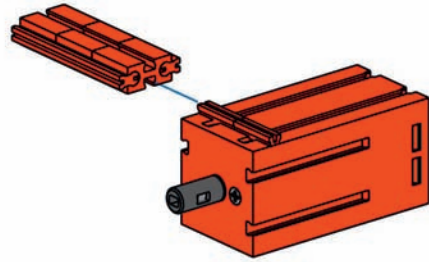
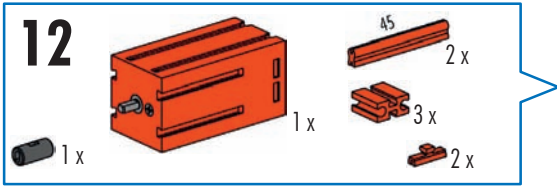

16

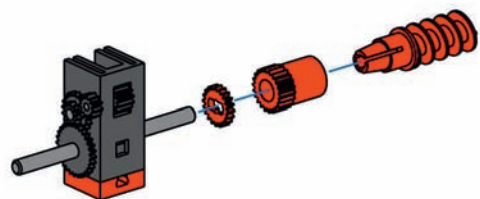

17

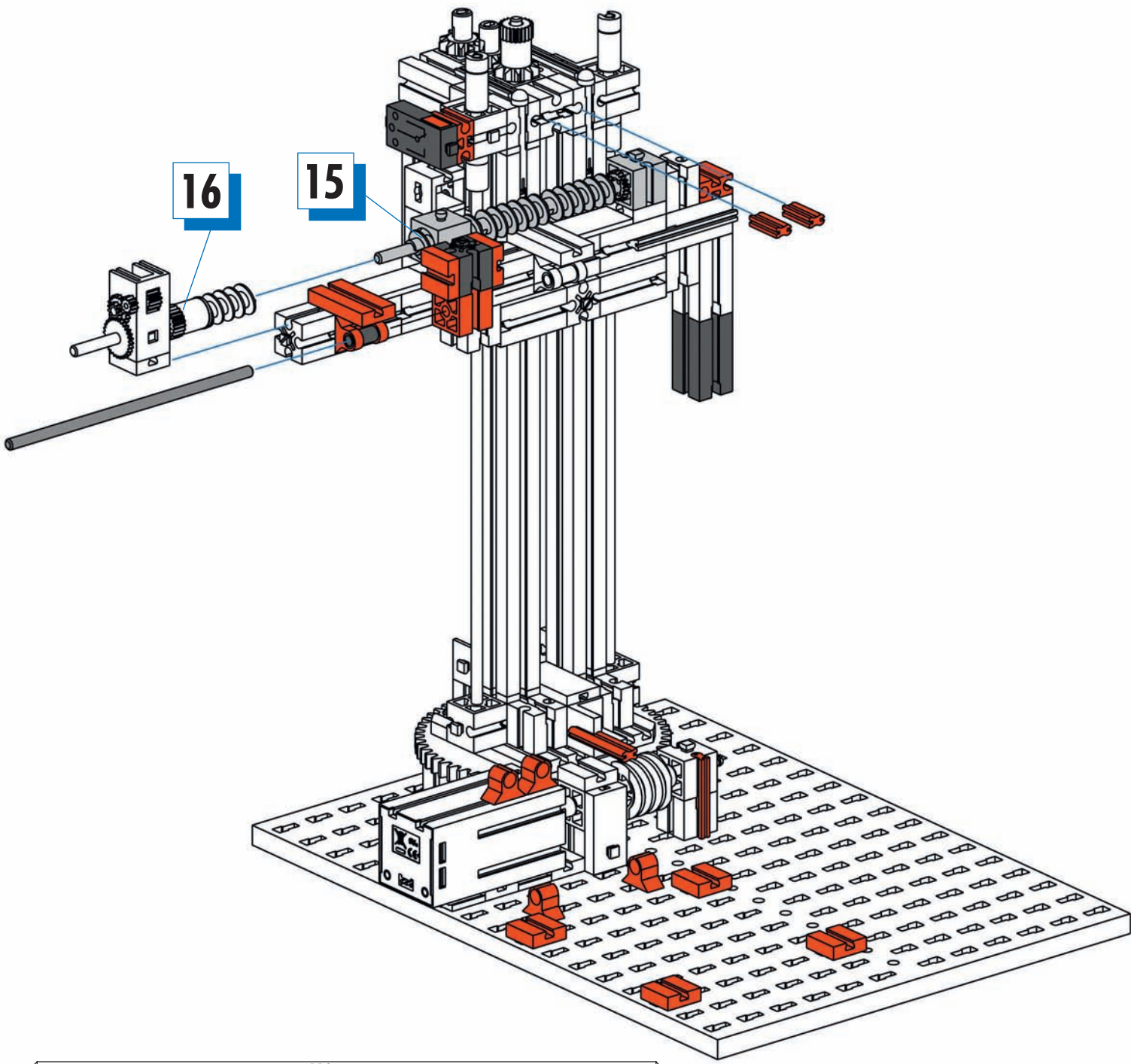
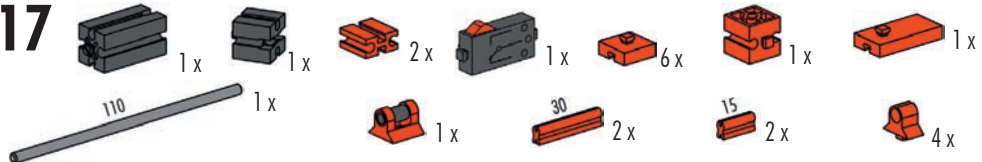

110 mm

18

- 2x [Grey Technic Brick 2x4]
- 2x [Grey Technic Brick 2x3]
- 5x [Red Technic Pin]
- 2x [Red Technic Pin]
- 2x [Red Technic Pin]
- 2x [Grey Technic Pin]
- 4x [Red Technic Pin]
- 3x [Red Technic Pin]
- 2x [Red Technic Pin]
- 1x [Grey Technic Pin 60]
- 2x [Red Technic Pin]

60 mm

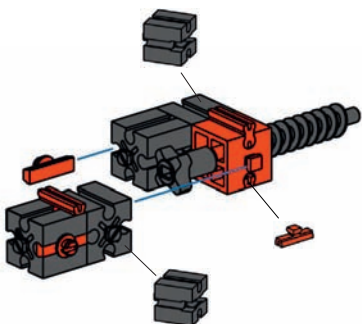
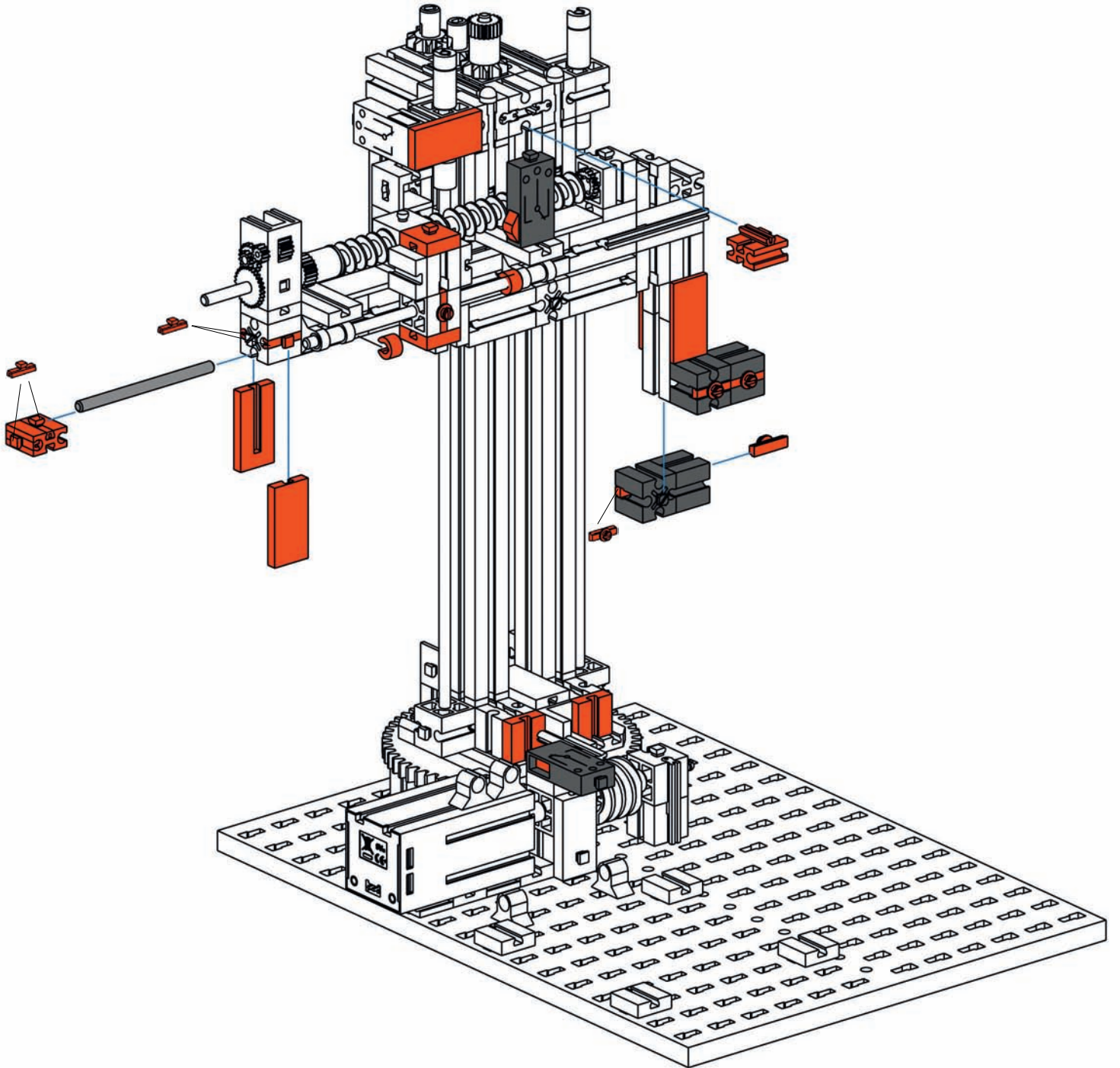

19

- 2x [Grey Technic Brick 2x4]
- 2x [Grey Technic Brick 2x3]
- 1x [Red Technic Brick 2x4]
- 1x [Grey Technic Pin 15]
- 1x [Red Technic Pin]
- 2x [Red Technic Pin]
- 2x [Red Technic Pin]
- 1x [Grey Technic Pin 15]

20

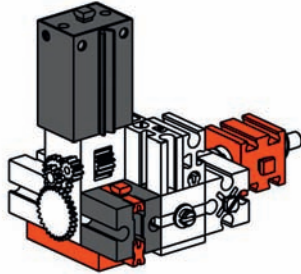
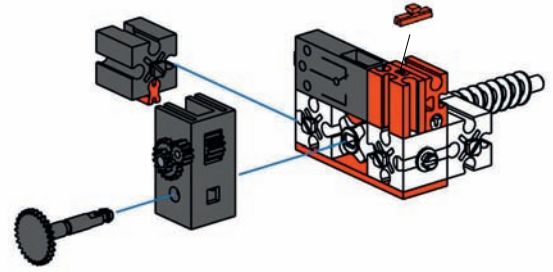
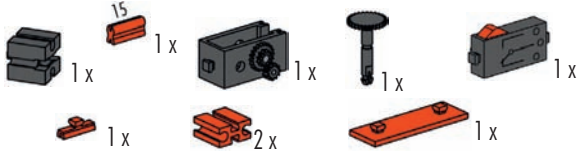

21

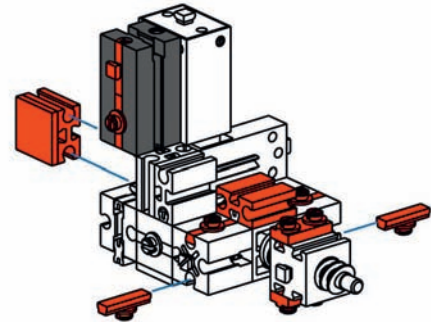
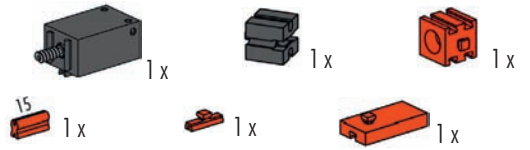

22

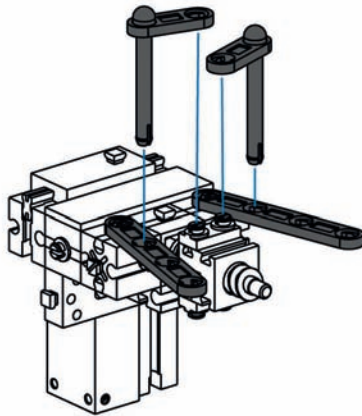
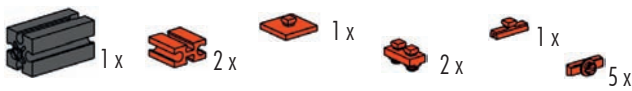

23

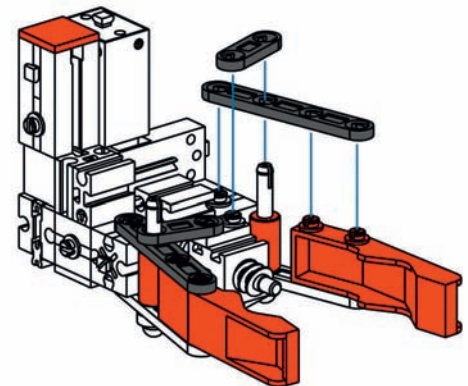

24

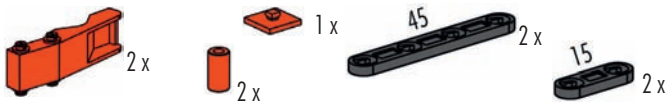

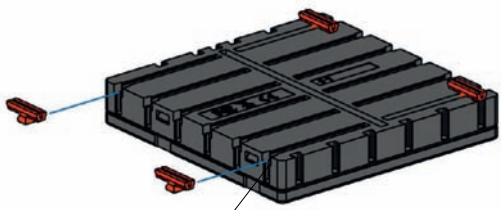

25



- ROBO TX Controller (Art.-Nr. 500 995) nicht im Baukasten enthalten
- ROBO TX Controller (Art.-Nr. 500 995) not included in the modular kit
- ROBO TX Controller (Art.-Nr. 500 995) n'est pas contenue dans le kit
- ROBO TX Controller (Art.-Nr. 500 995) niet in de bouwdoos opgenomen
- ROBO TX Controller (Art.-Nr. 500 995) no está incluido en el conjunto
- ROBO TX Controller (Art.-Nr. 500 995) não contido no sistema de construção por blocos
- ROBO TX Controller (Art.-Nr. 500 995) non incluso nella scatola di montaggio
- ROBO TX Controller (Art.-Nr. 500 995) не входит в комплект конструктора
- ROBO TX Controller (Art.-Nr. 500 995) 不包含在组件

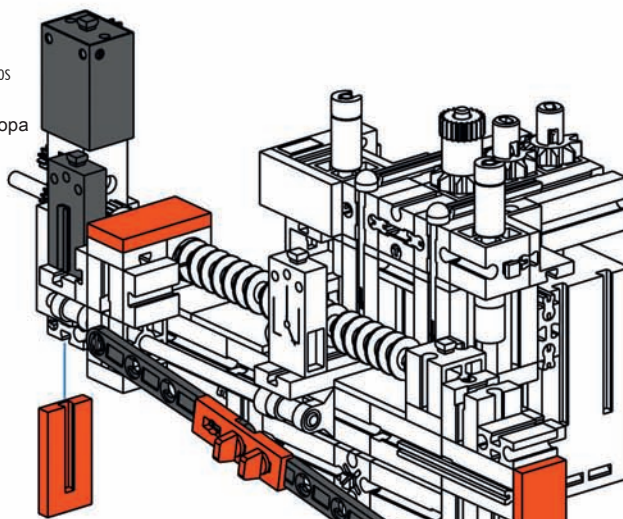

24

26

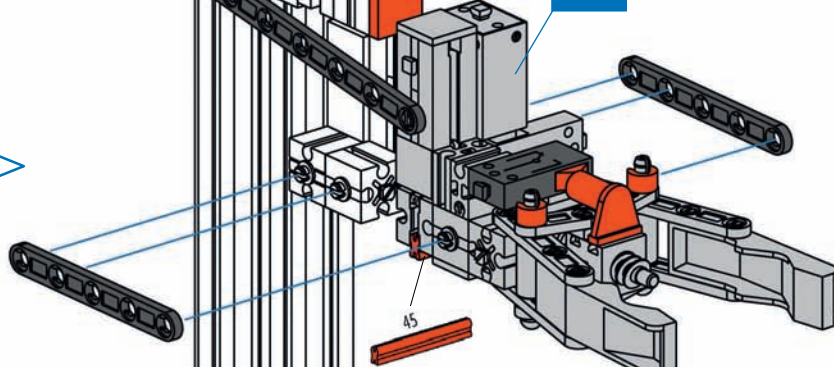
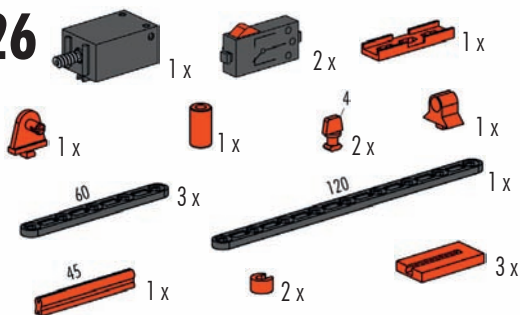



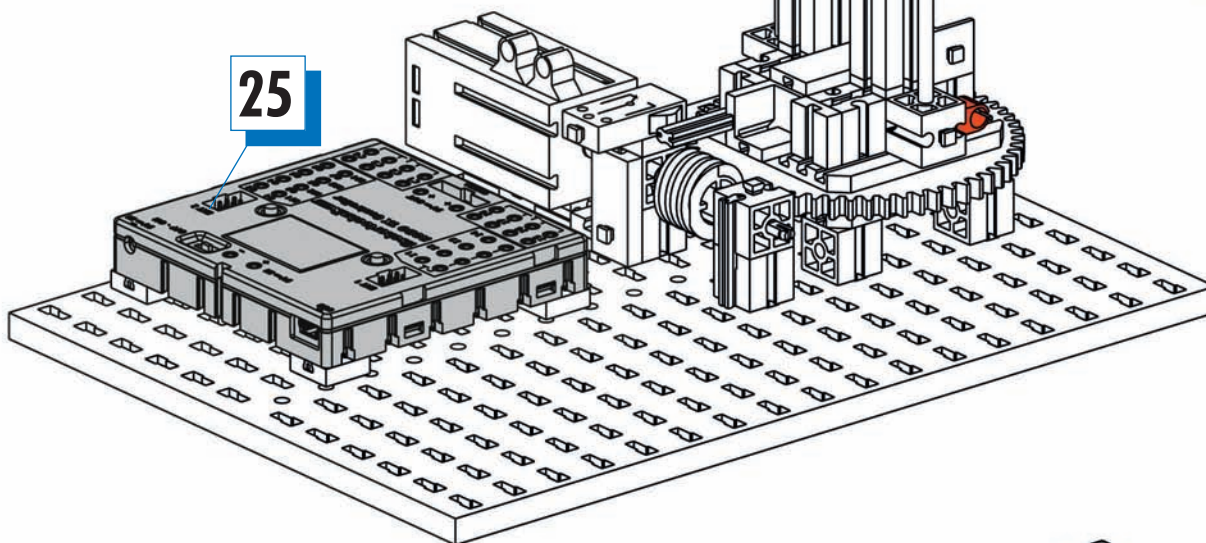

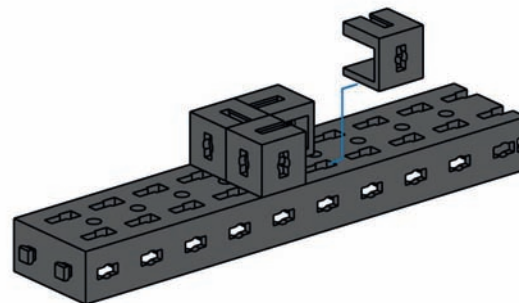
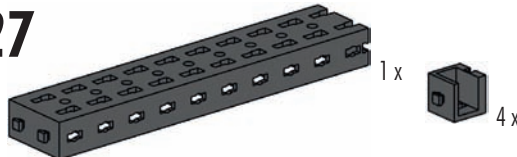

25

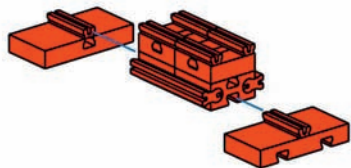



27



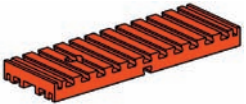

28  2x  2x  2x  2x
 6x

29  1x  4x
 4x

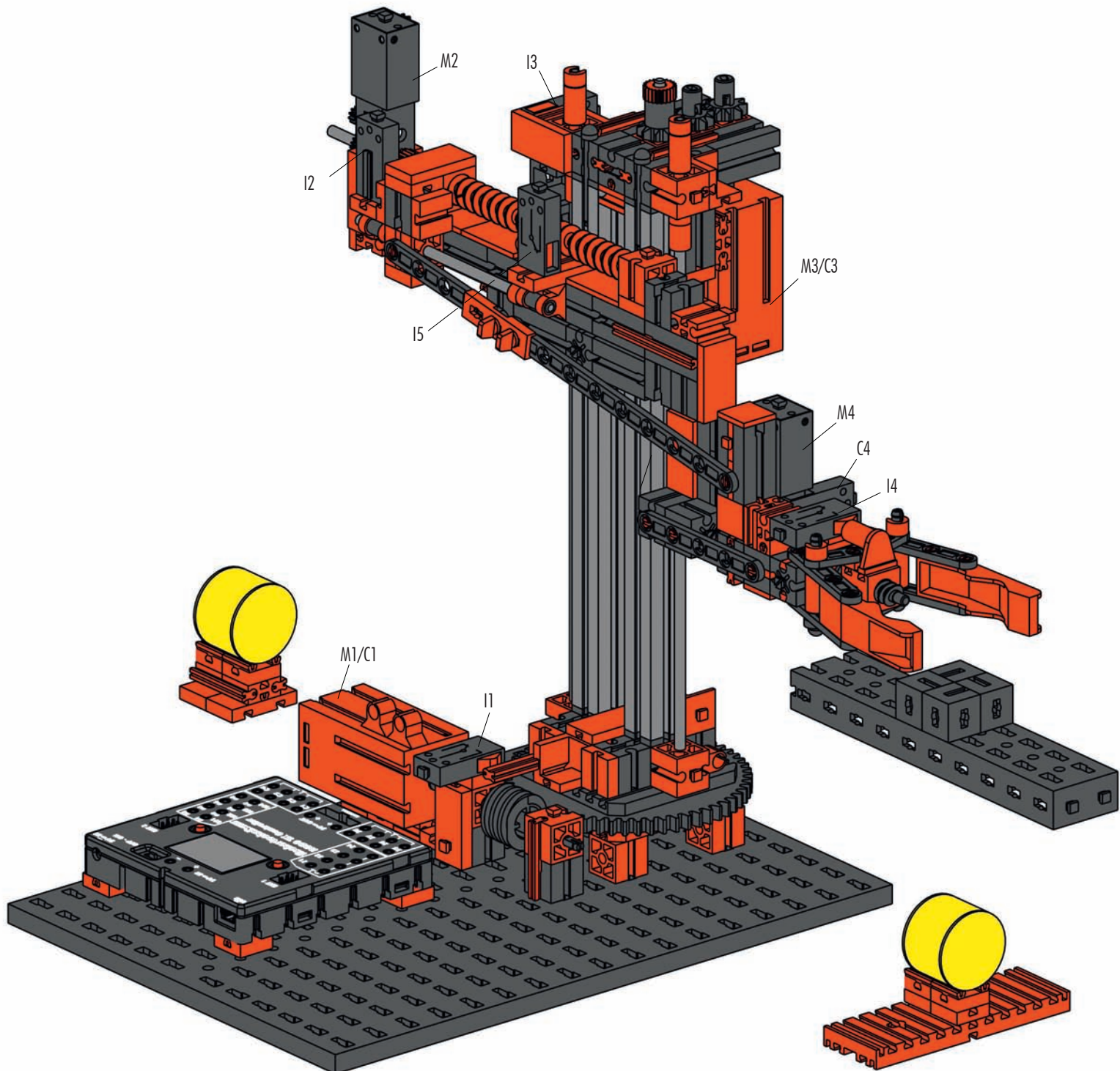
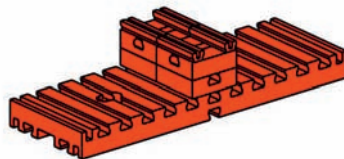

Schaltplan
Circuit diagram
Plan électrique

Schakelschema
Diagrama de circuitos
Plano elétrico de ligação

Schema elettrico
Схема подключения
电路图

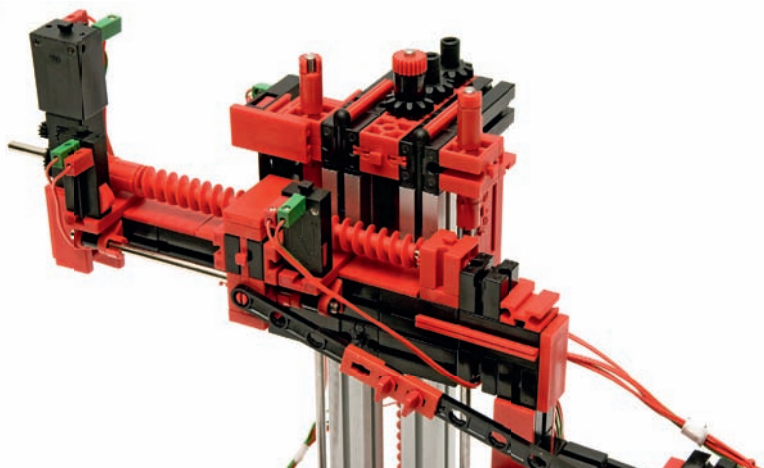
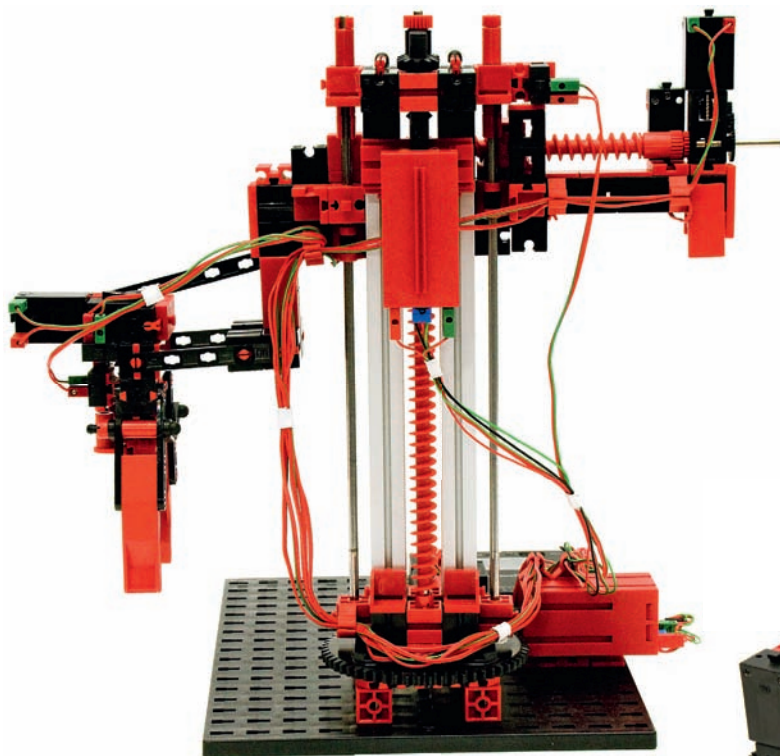
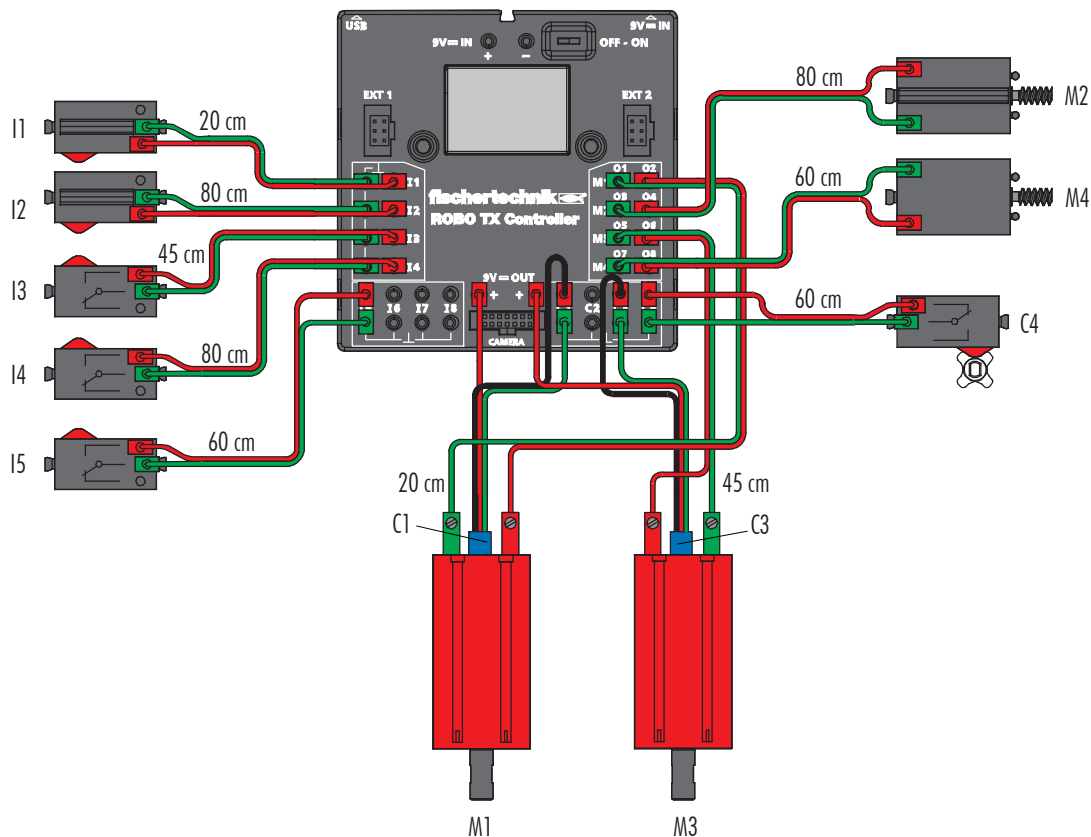

- Informationen zur Programmierung des Modells: Siehe didaktisches Begleitmaterial.
- Information on programming model: See related instructional material.
- Informations concernant la programmation de la maquette : voir le matériel d'accompagnement didactique.
- Informatie over de programmering van het model: Zie het didactisch begeleidend materiaal.
- Informaciones sobre la programación del modelo: Véase material didáctico adjunto.
- Informações sobre a programação do modelo: ver o material didático de acompanhamento.
- Informazioni sulla programmazione del modello: vedi materiale didattico.
- Информация о программировании модели: смотрите обучающий сопроводительный материал на CD.
- 有关该模型编程的信息：见 CD 光盘上的指导性说明资料。

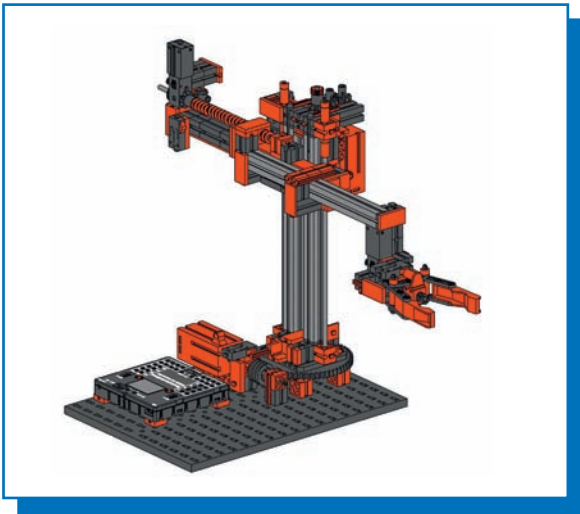

3-Achs-Roboter
3-axis robot
Robot à 3 axes

3-assige robot
Robot de 3 ejes
Robô de 3 eixos

Robot a 3 assi
 Трёхосный робот
 3 轴机器人

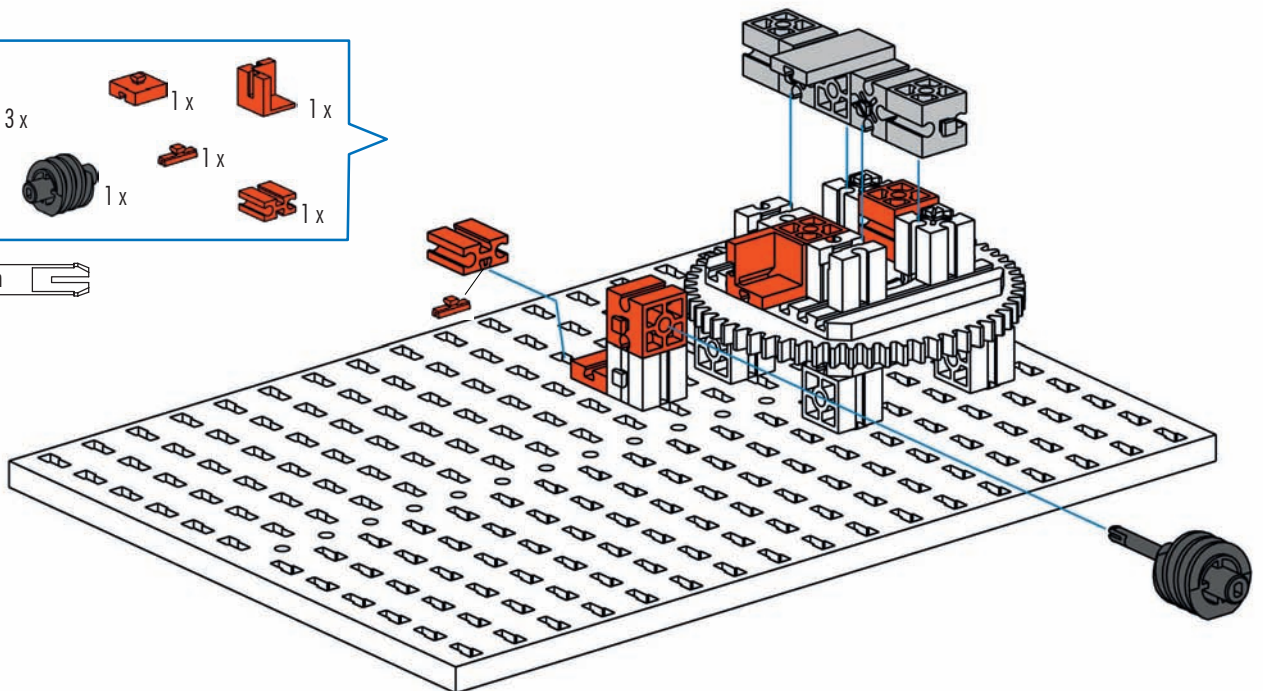
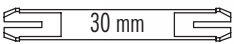
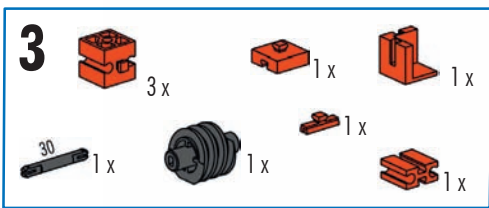
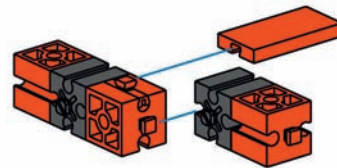
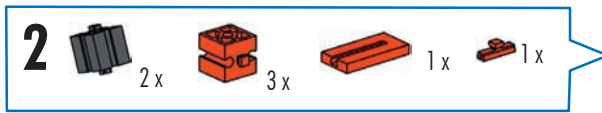
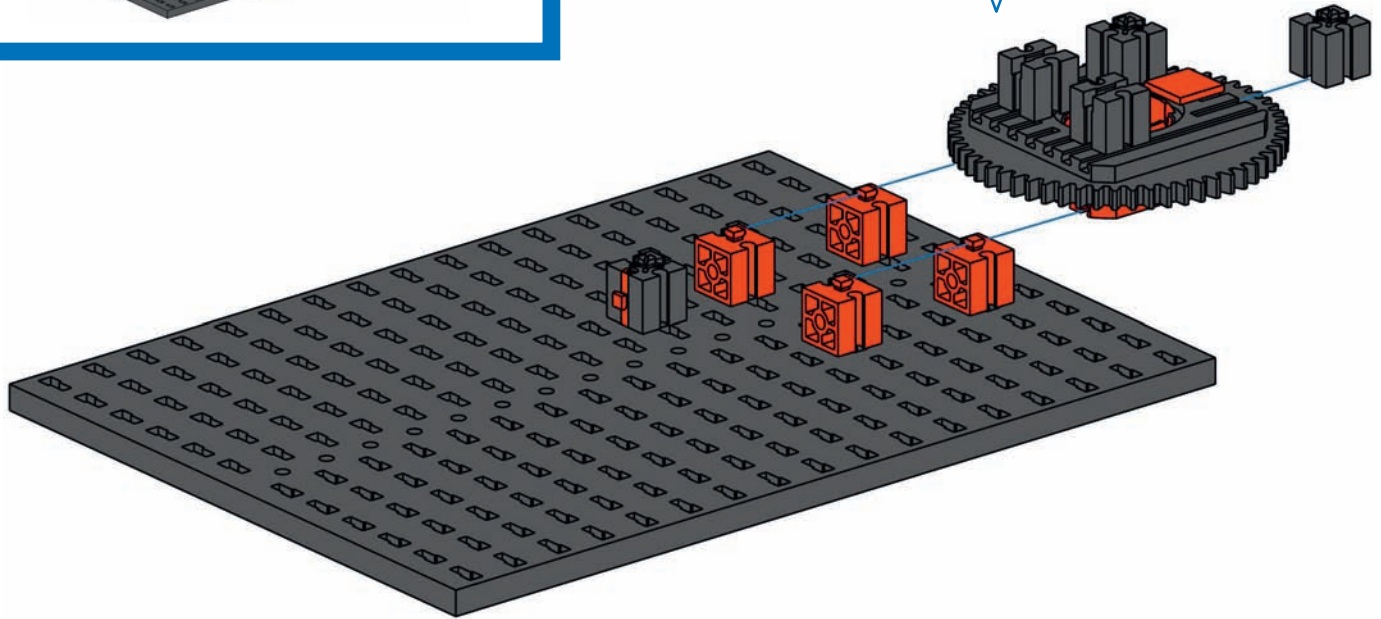
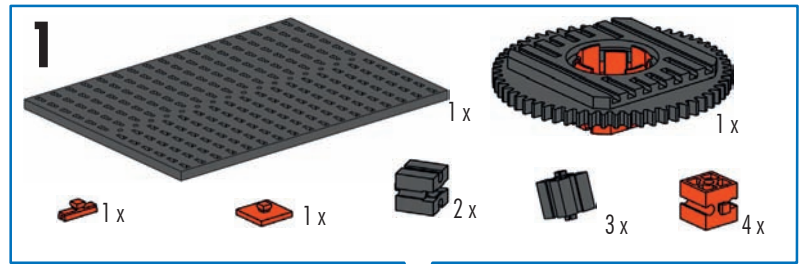

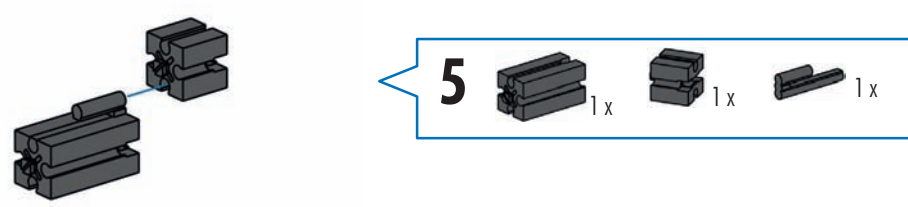
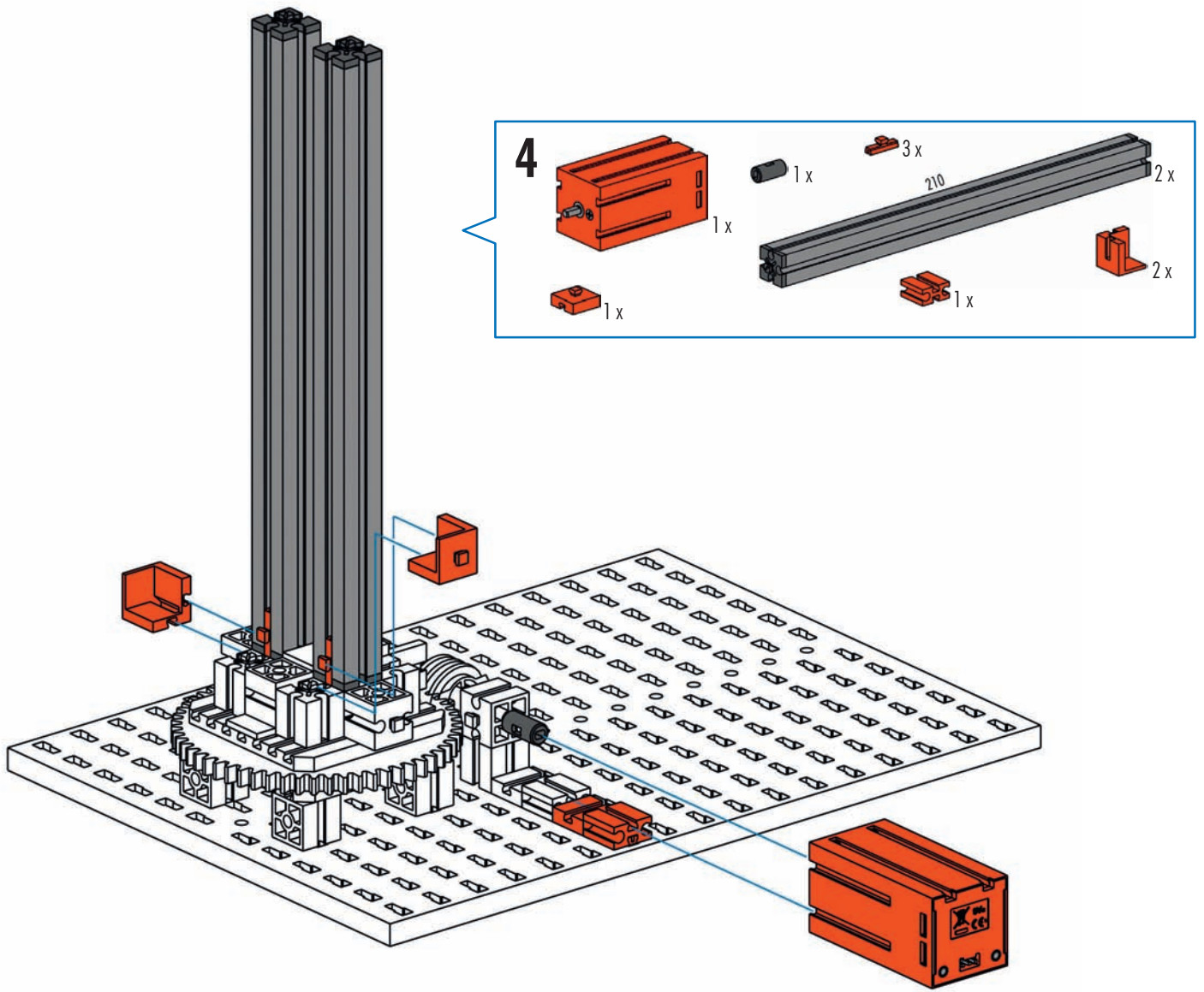

7

- 1x [Red Pin]
- 1x [Red Pin]
- 1x [Grey Axle 260]
- 1x [Red Spring]
- 5x [Red Spring]
- 2x [Red Technic Brick 1x2]

15 mm

8

- 1x [Grey Technic Brick 1x2]
- 1x [Red Technic Plate 1x3]
- 1x [Red Technic Brick 1x2]
- 1x [Red Technic Brick 1x2]
- 1x [Red Technic Brick 1x2]
- 1x [Red Technic Pin]
- 2x [Red Technic Pin]
- 1x [Black Technic Pin]

6

8

9

- 1x [Grey Technic Brick 1x2]
- 3x [Grey Technic Brick 1x2]
- 1x [Grey Technic Brick 1x2]
- 1x [Red Technic Brick 1x2]
- 2x [Red Technic Pin]
- 1x [Red Technic Plate 1x3]
- 1x [Red Technic Brick 1x2]
- 1x [Red Technic Brick 1x2]
- 1x [Red Technic Pin]
- 1x [Red Technic Pin]
- 1x [Red Technic Pin]

260 mm

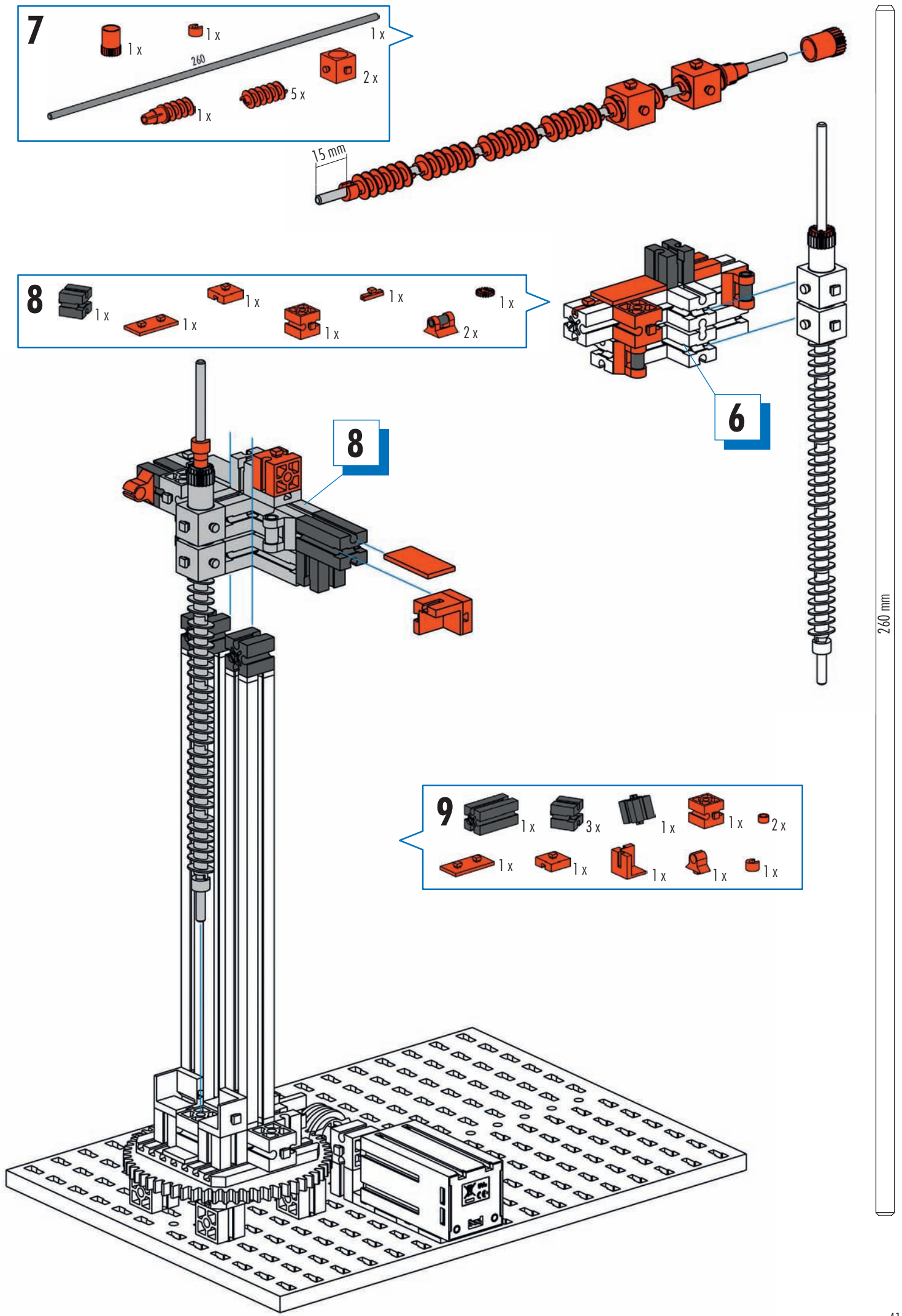

- 10** 1x 3x 1x 1x 15 2x

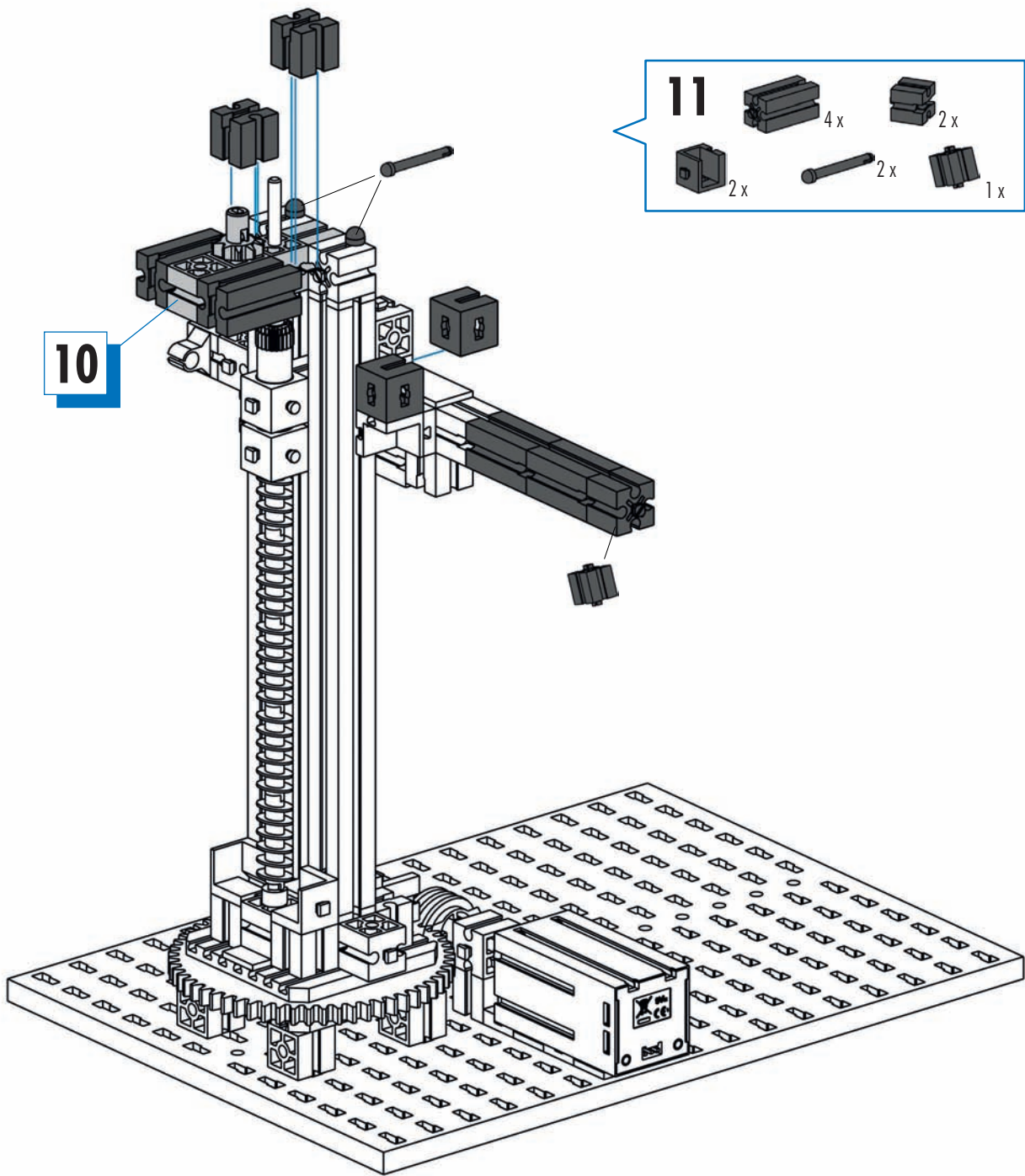
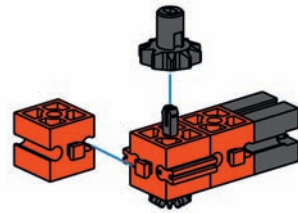

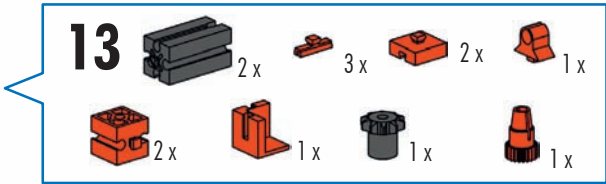
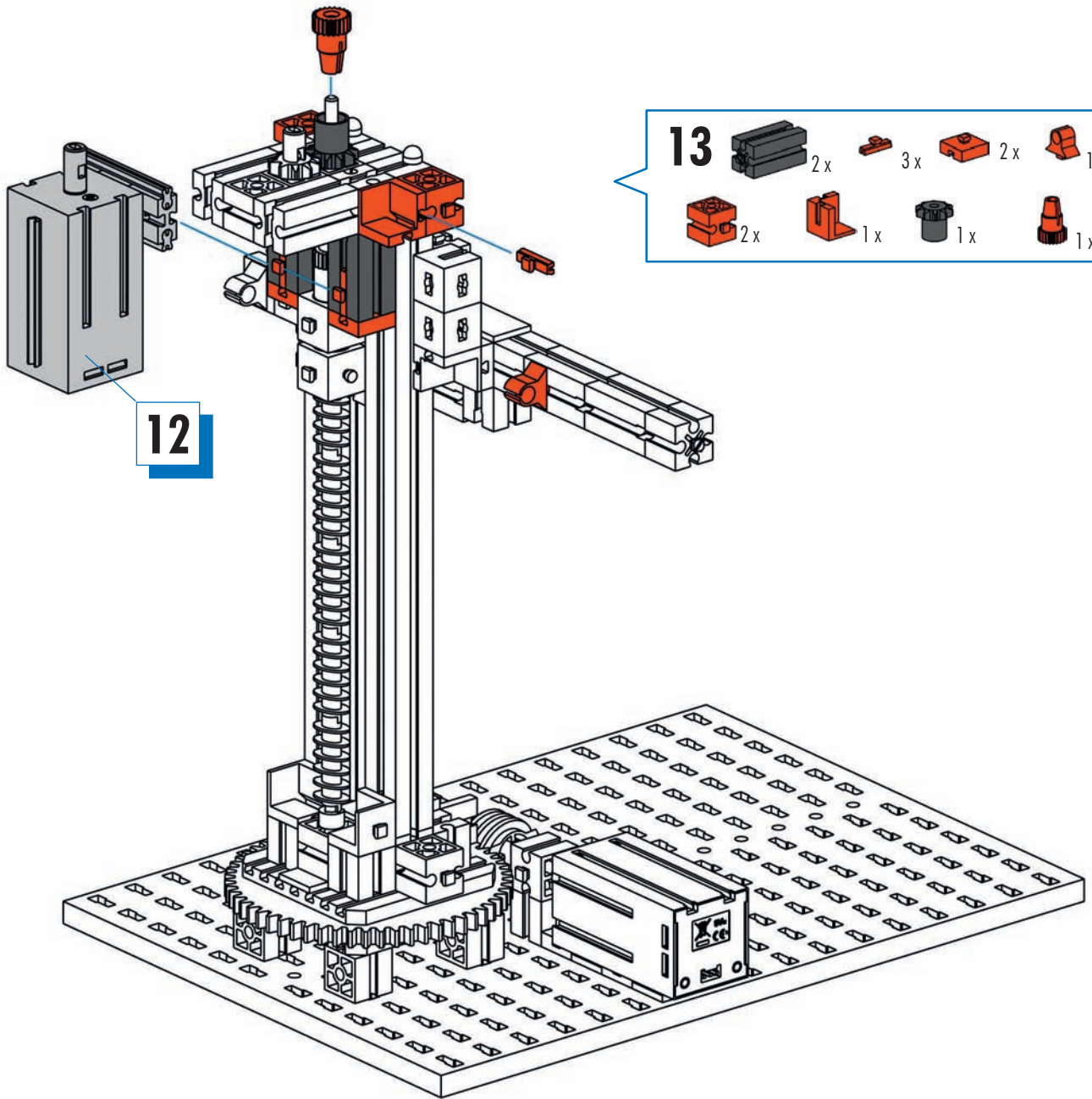
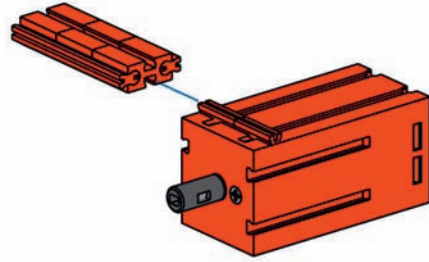
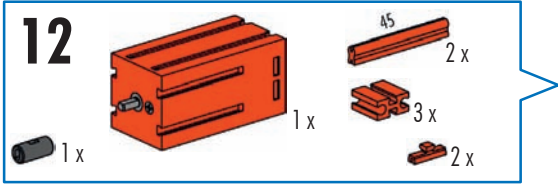

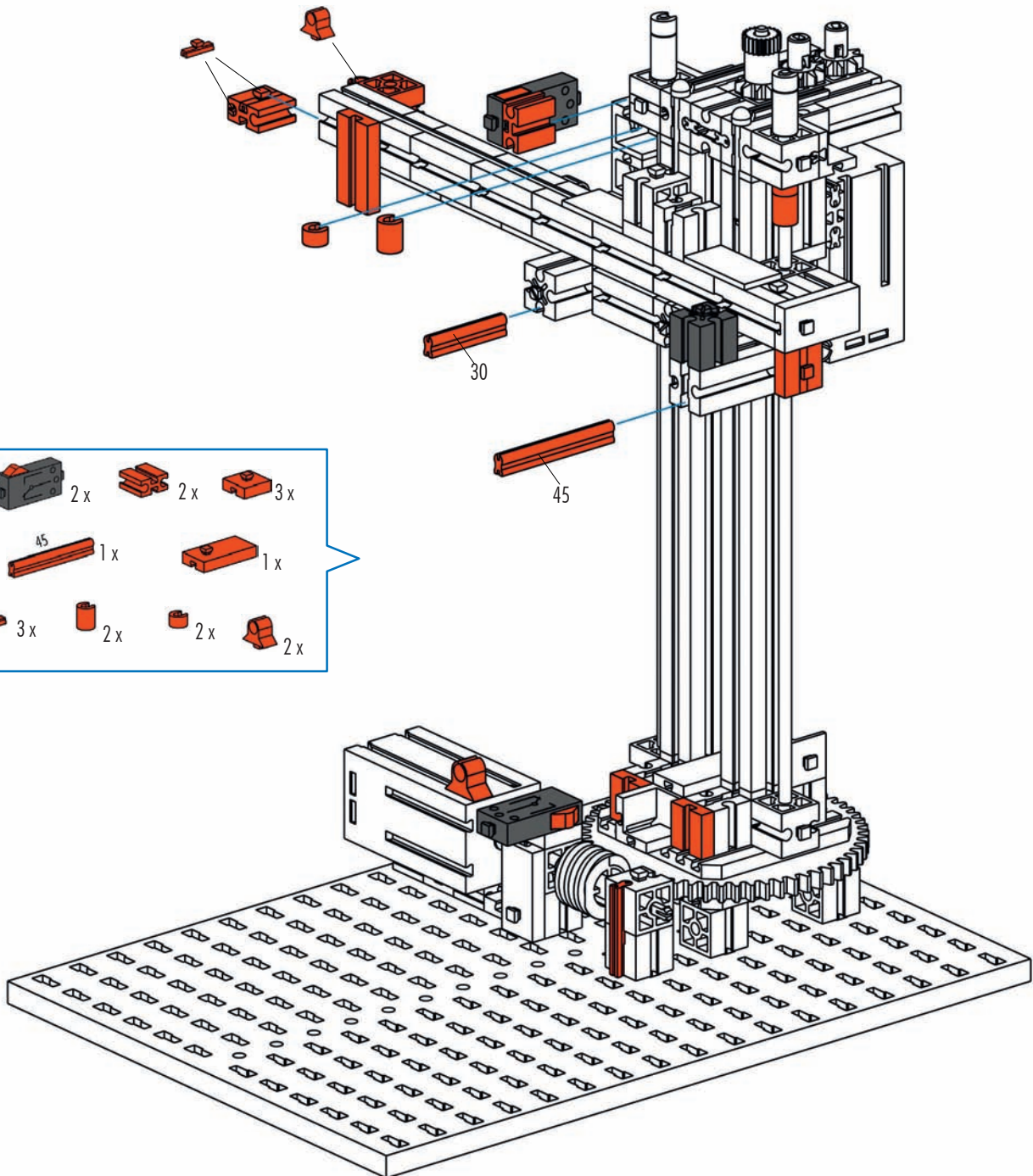

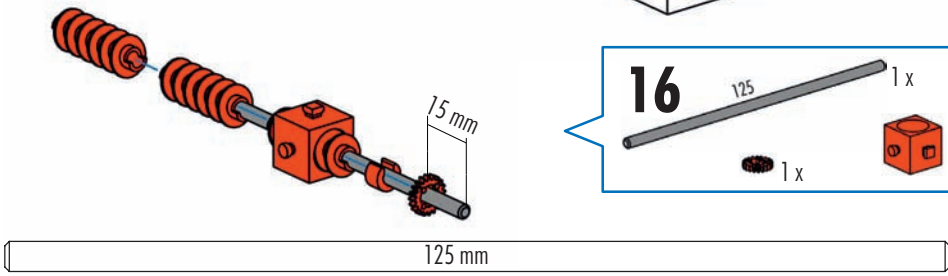

- 15**
- 1x [Grey Technic Axle]
 - 2x [Grey Technic Motor]
 - 2x [Orange Technic Connector]
 - 3x [Orange Technic Pin]
 - 2x [Orange Technic Axle 30]
 - 1x [Orange Technic Axle 45]
 - 1x [Orange Technic Plate]
 - 1x [Orange Technic Connector]
 - 3x [Orange Technic Pin]
 - 2x [Orange Technic Pin]
 - 2x [Orange Technic Pin]
 - 2x [Orange Technic Pin]

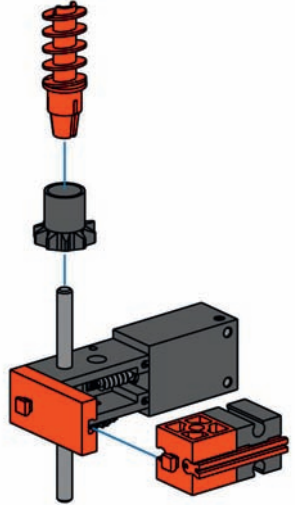

- 16**
- 1x [Grey Technic Axle 125]
 - 3x [Red Spring]
 - 1x [Red Technic Connector]
 - 1x [Red Technic Pin]
 - 1x [Red Technic Pin]

- 17**
- 1x [Grey Technic Axle]
 - 1x [Grey Technic Motor]
 - 1x [Grey Technic Motor]
 - 1x [Red Spring]
 - 1x [Orange Technic Plate]
 - 1x [Grey Technic Connector]
 - 1x [Orange Technic Connector]
 - 1x [Orange Technic Axle 30]
 - 1x [Grey Technic Pin]



18  1x 1x 1x 1x 30 1x

 30 mm

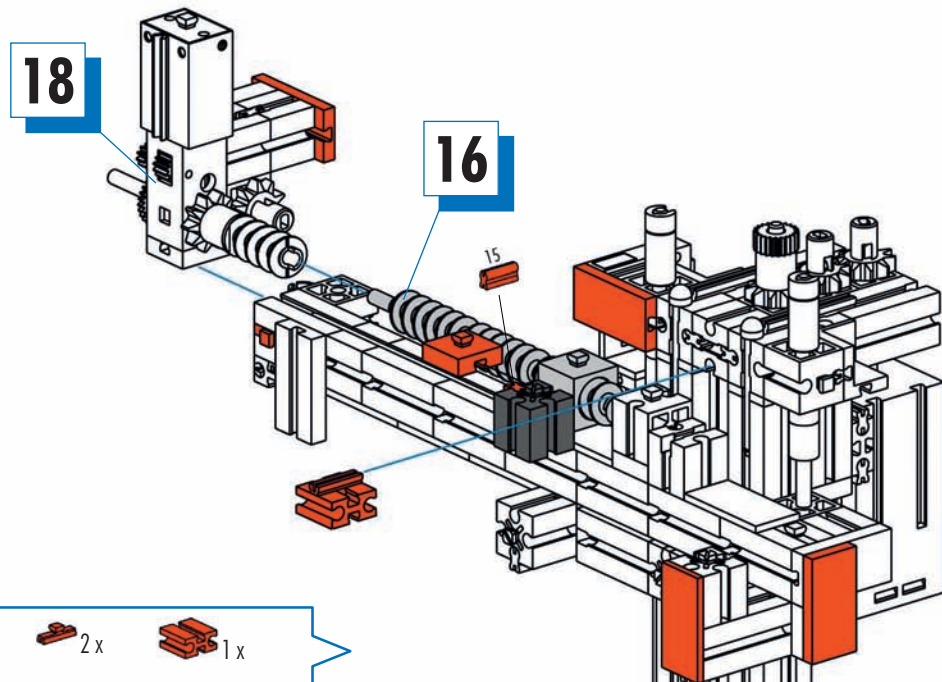
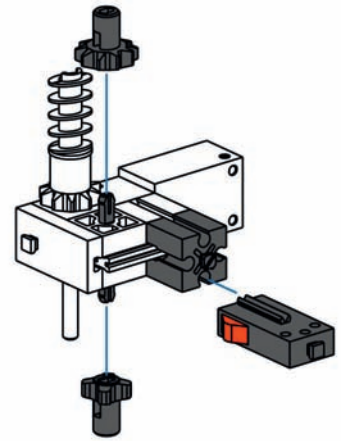

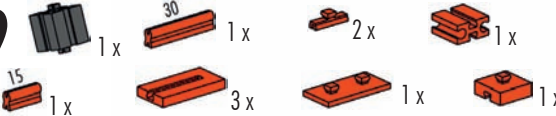
19  1x 30 1x 2x 1x 15 1x 3x 1x 1x

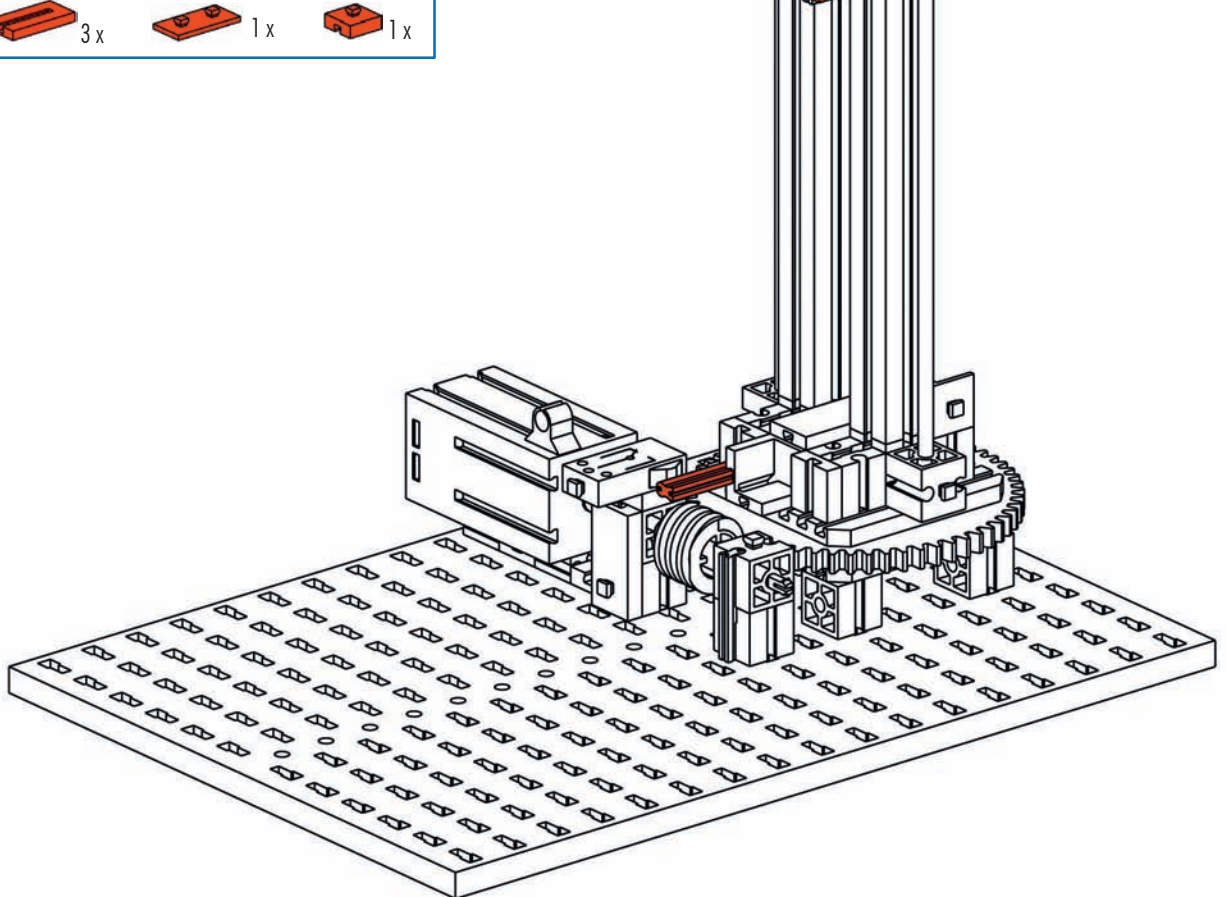

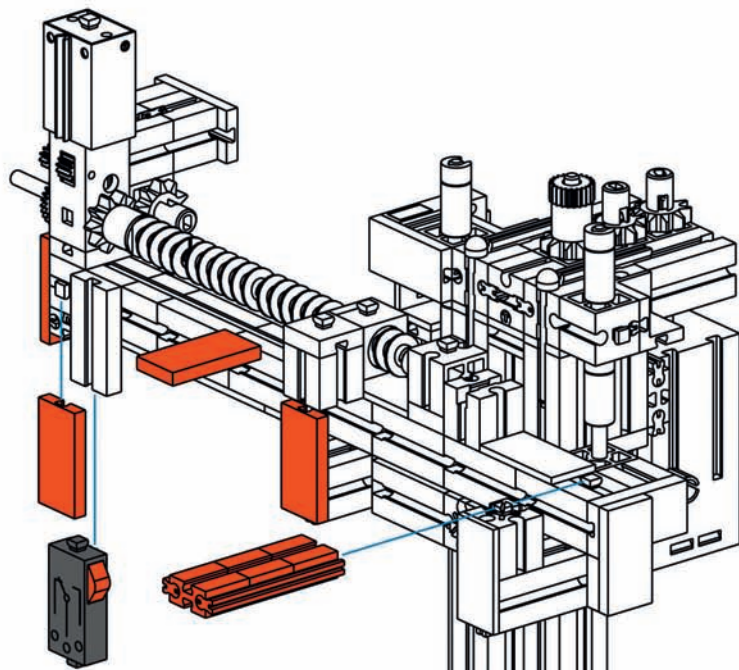

20

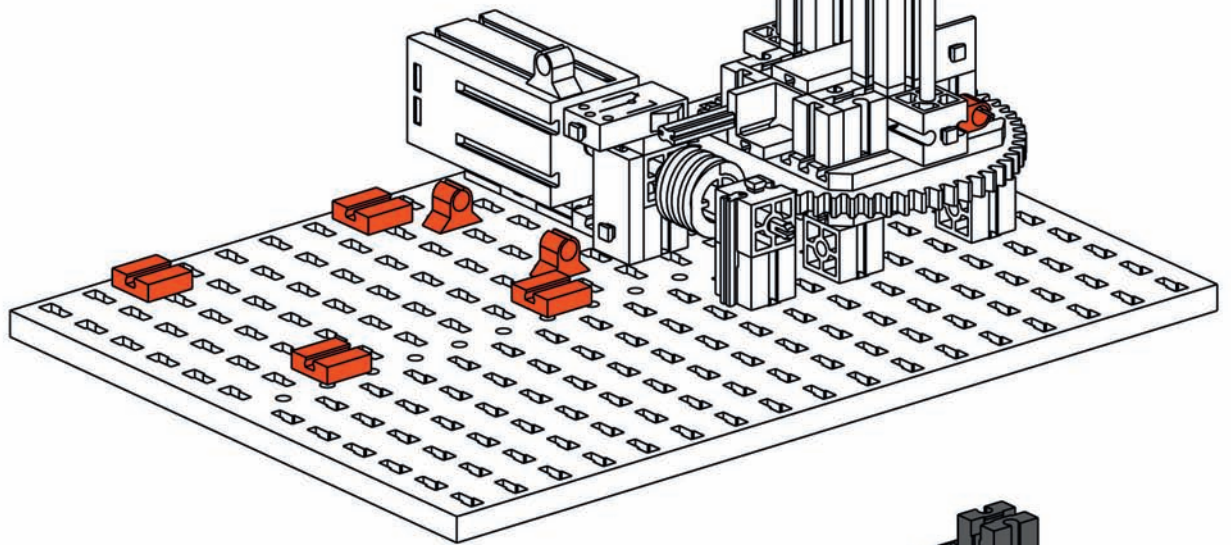
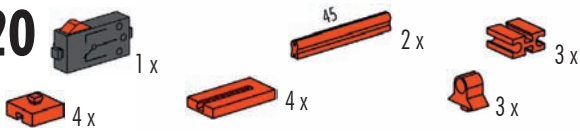

21

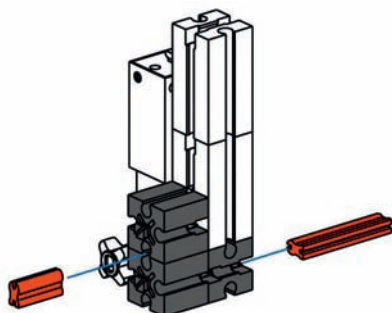
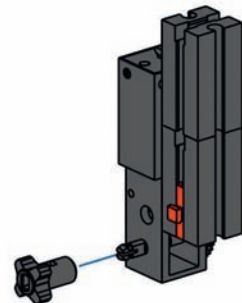

22



23

- 1x [Grey Technic Pin]
- 2x [Grey Technic Pin]
- 1x [Red Technic Pin]
- 1x [Red Technic Pin]
- 1x [Red Technic Pin]
- 4x [Red Technic Pin]
- 4x [Red Technic Pin]

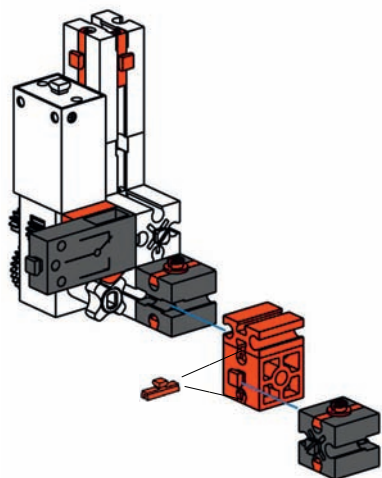

24

- 1x [Grey Technic Pin]
- 1x [Grey Technic Pin]
- 1x [Red Technic Pin 30]
- 2x [Red Technic Pin]
- 2x [Red Technic Pin]
- 1x [Red Technic Pin]
- 1x [Red Technic Pin]
- 2x [Red Technic Pin 45]

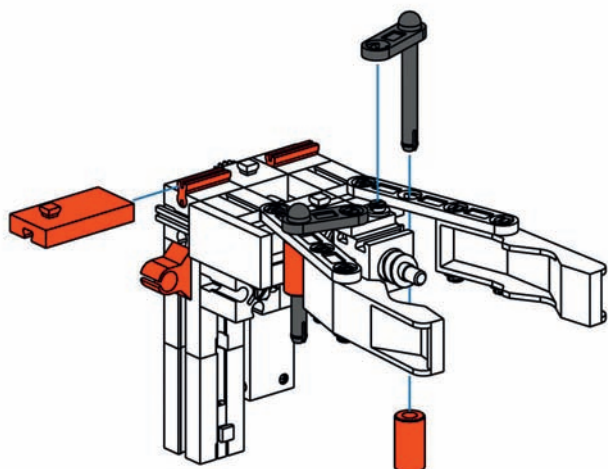

25

- 1x [Red Technic Pin]
- 2x [Red Technic Pin]
- 2x [Red Technic Pin]
- 2x [Red Technic Pin 15]
- 1x [Red Technic Pin]

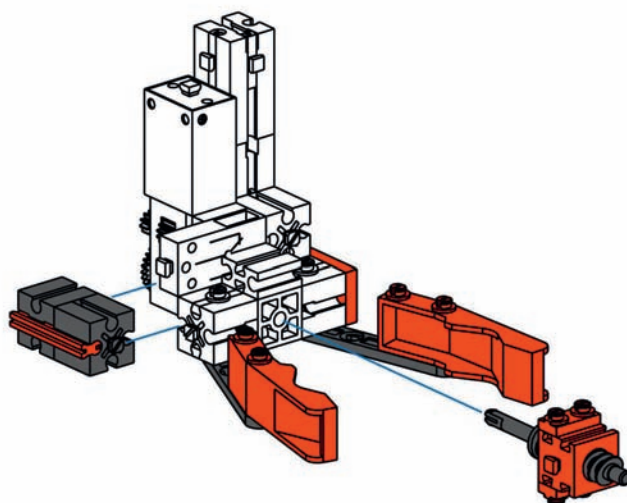

26

- 1x [Red Technic Pin]
- 1x [Red Technic Pin 210]
- 2x [Red Technic Pin]
- 2x [Red Technic Pin 15]
- 2x [Red Technic Pin 45]

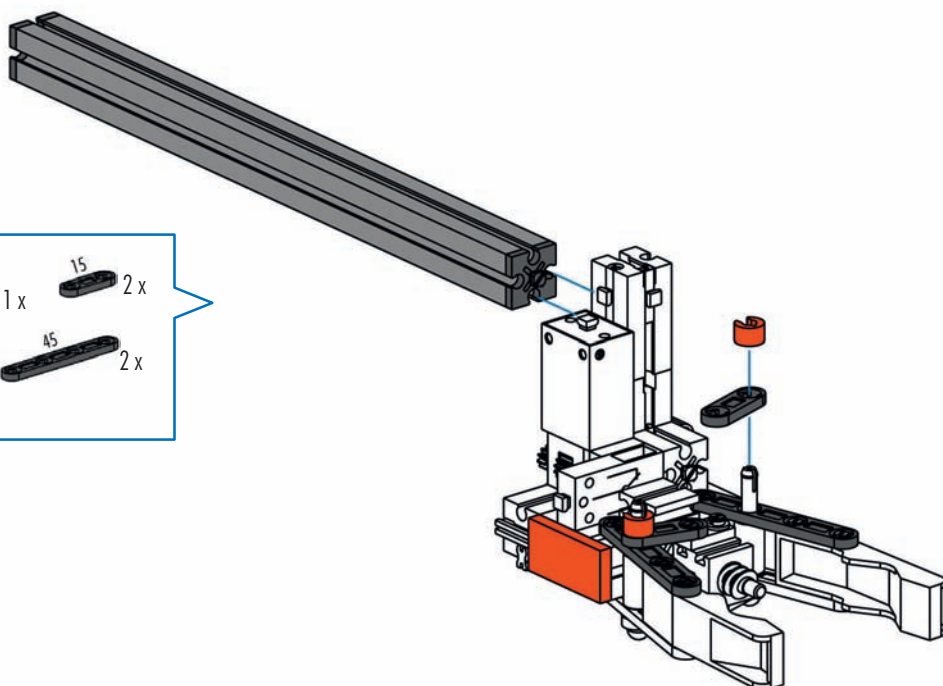

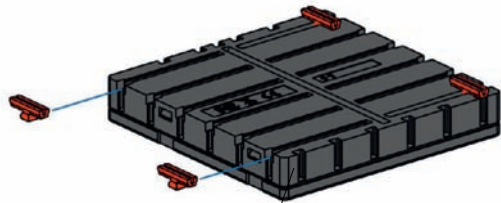

27



- ROBO TX Controller (Art.-Nr. 500 995) nicht im Baukasten enthalten
- ROBO TX Controller (Art.-Nr. 500 995) not included in the modular kit
- ROBO TX Controller (Art.-Nr. 500 995) n'est pas contenue dans le kit
- ROBO TX Controller (Art.-Nr. 500 995) niet in de bouwdoos opgenomen
- ROBO TX Controller (Art.-Nr. 500 995) no está incluido en el conjunto
- ROBO TX Controller (Art.-Nr. 500 995) não contido no sistema de construção por blocos
- ROBO TX Controller (Art.-Nr. 500 995) non incluso nella scatola di montaggio
- ROBO TX Controller (Art.-Nr. 500 995) не входит в комплект конструктора
- ROBO TX Controller (Art.-Nr. 500 995) 不包含在组件

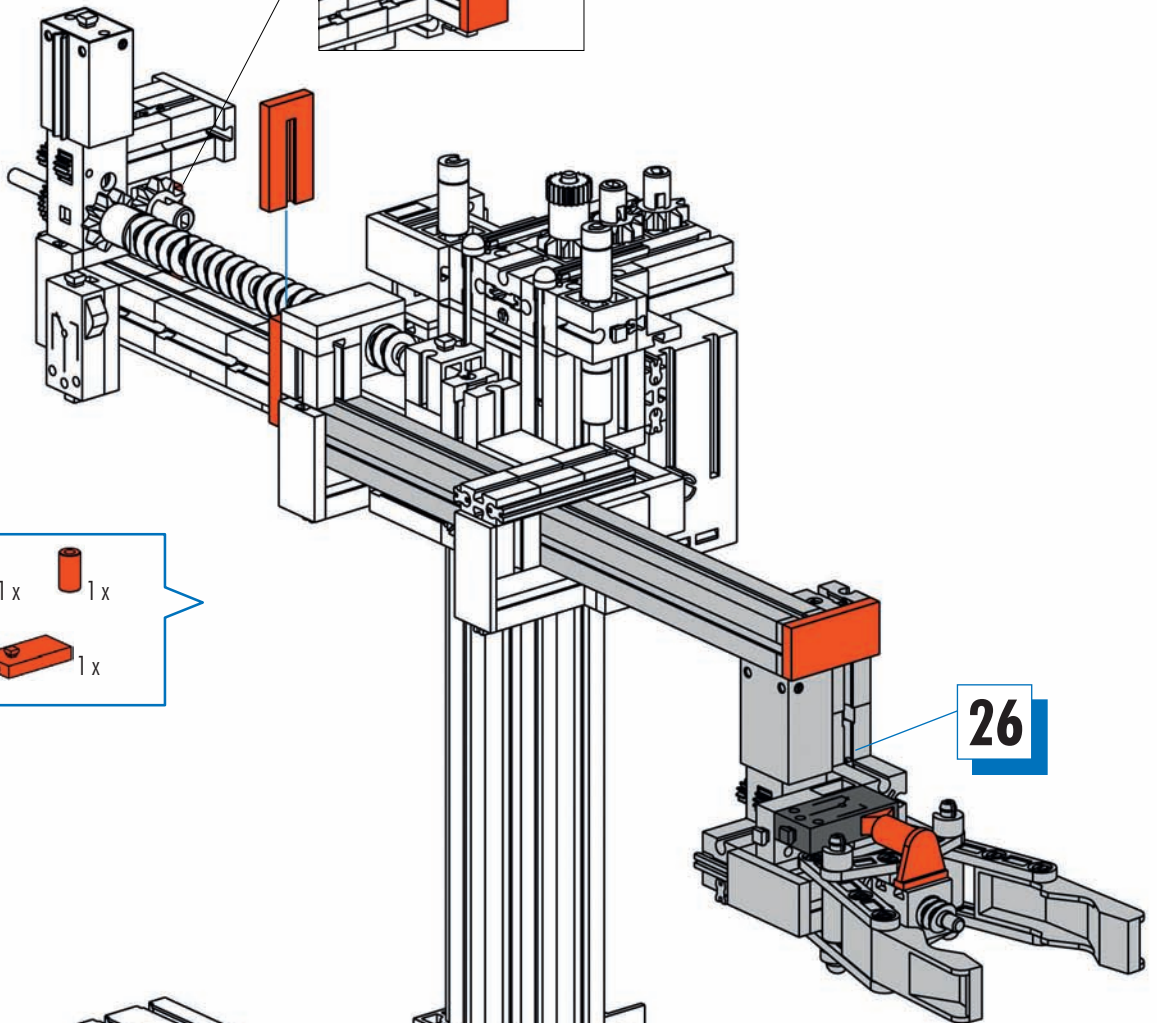
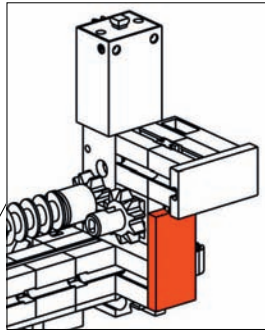

28

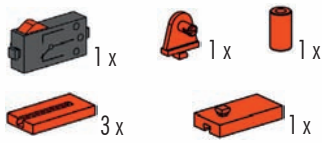

27

26

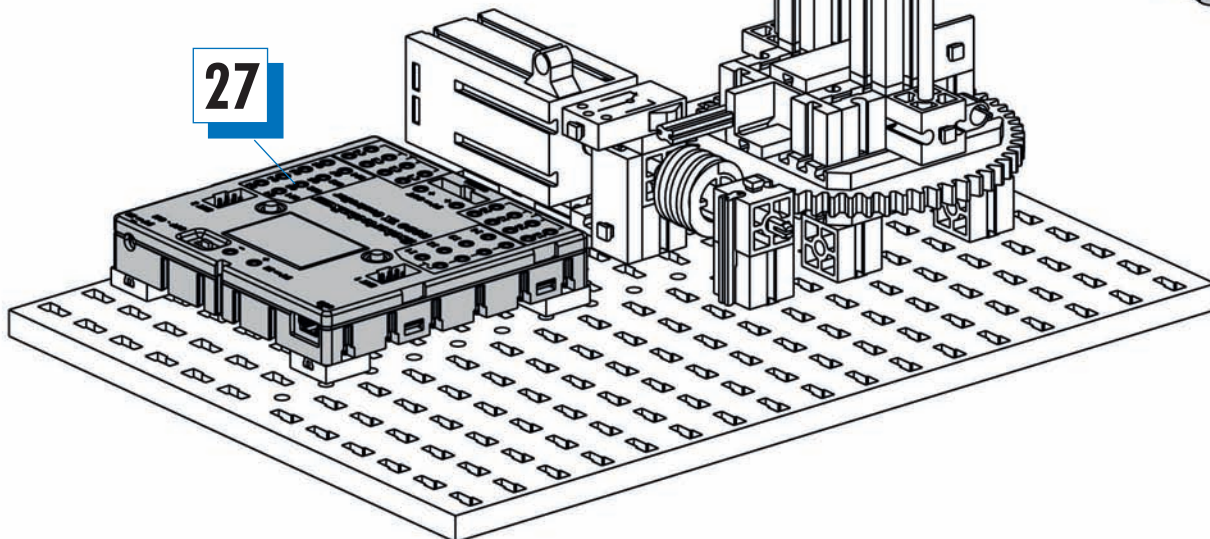

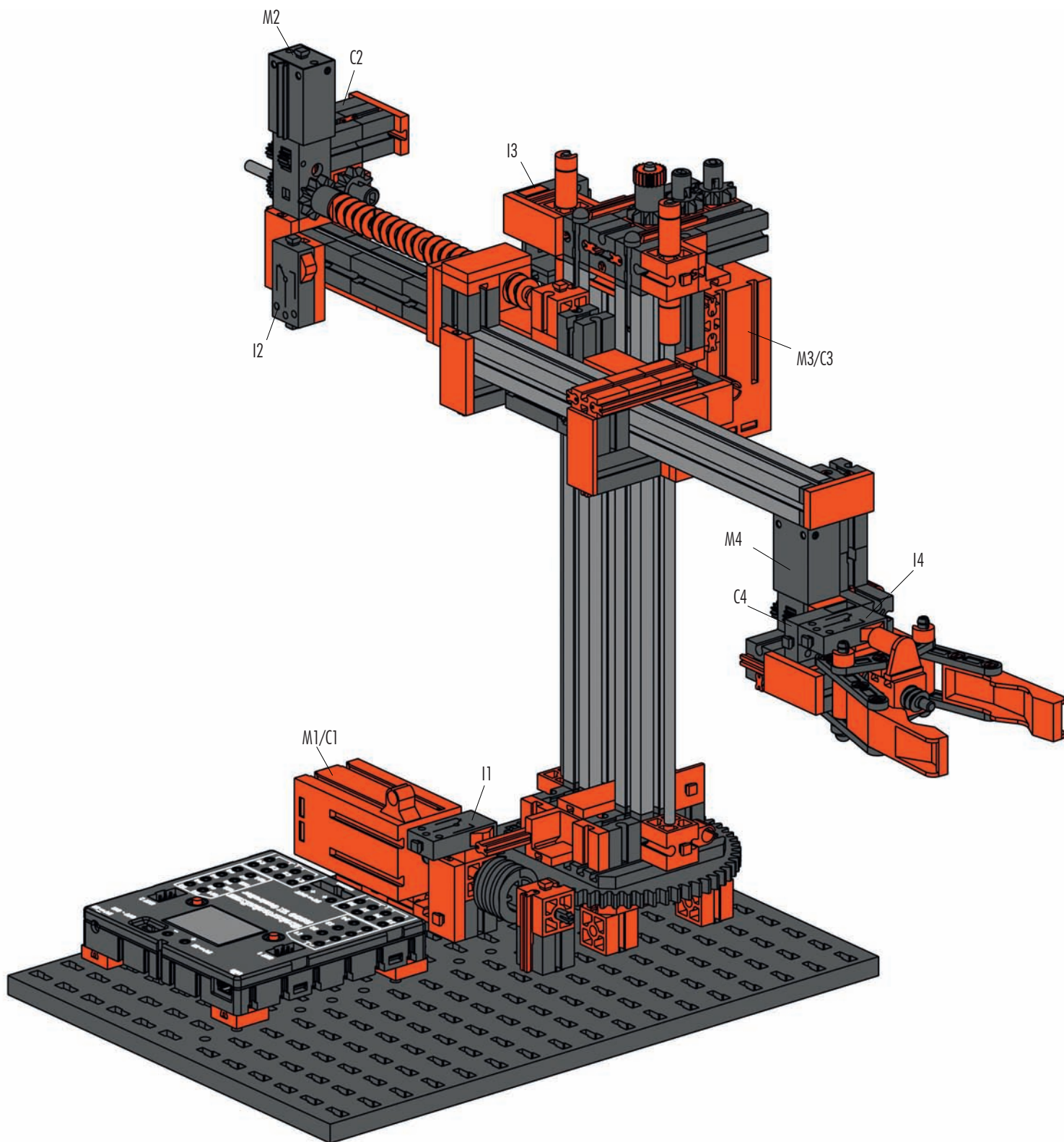

Schaltplan
Circuit diagram
Plan électrique

Schakelschema
Diagrama de circuitos
Plano elétrico de ligação

Schema elettrico
Схема подключения
电路图

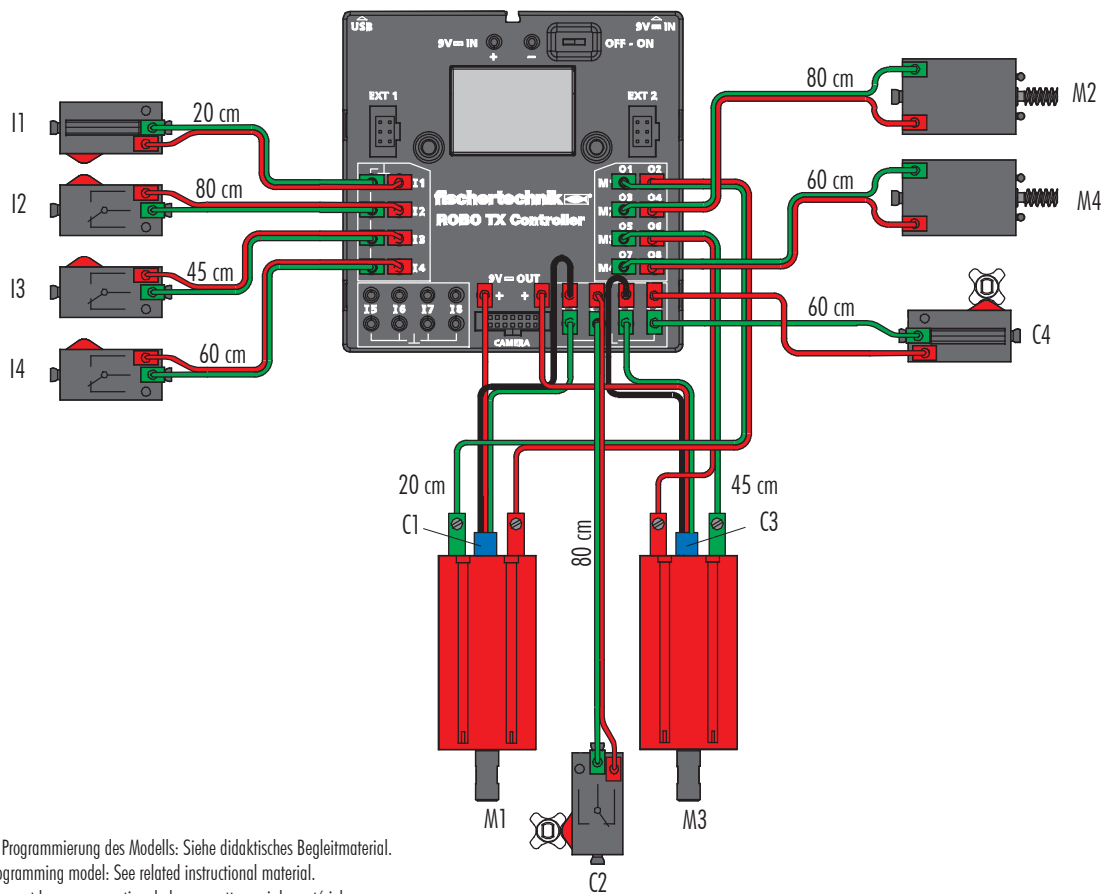

- Informationen zur Programmierung des Modells: Siehe didaktisches Begleitmaterial.
- Information on programming model: See related instructional material.
- Informations concernant la programmation de la maquette : voir le matériel d'accompagnement didactique.
- Informatie over de programmering van het model: Zie het didactisch begeleidend materiaal.
- Informaciones sobre la programación del modelo: Véase material didáctico.
- Informações sobre a programação do modelo: ver o material didático de acompanhamento.
- Informazioni sulla programmazione del modello: vedi materiale didattico.
- Информация о программировании модели: смотрите обучающий сопроводительный материал на CD.
- 有关该模型编程的信息：见 CD 光盘上的指导性说明资料。

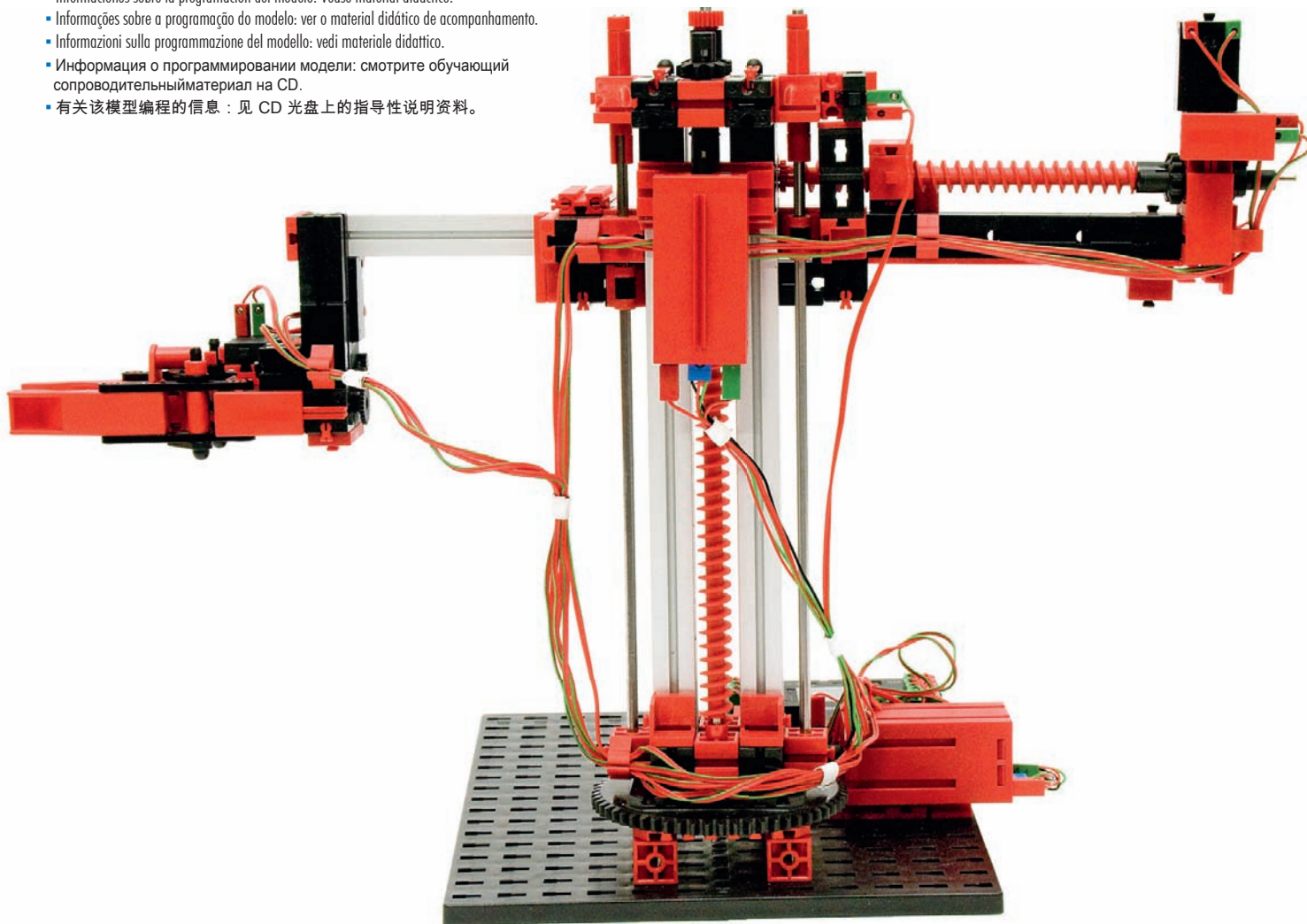

Empfohlene Aufbewahrung:	4 x Aufbewahrungssystem Art.-Nr. 94828
Recommended storage:	4 x storage system Art No. 94828
Stockage conseillé :	4 x système de stockage Art n° 94828
Bewaaradvies:	4 x bewaarsysteem art.-nr. 94828
Consejos para guardar el producto:	4 x almacenamiento Art. N° 94828
Conservação recomendada:	4 x sistema de conservação n.º de art. 94828
Conservazione consigliata:	4 sistemi di conservazione, cod. prod. 94828
Рекомендуемое хранение:	4 x бокса для хранения. Арт.№ 94 828
推荐的保存方式 :	4 个产品号为 94 828 的保存系统

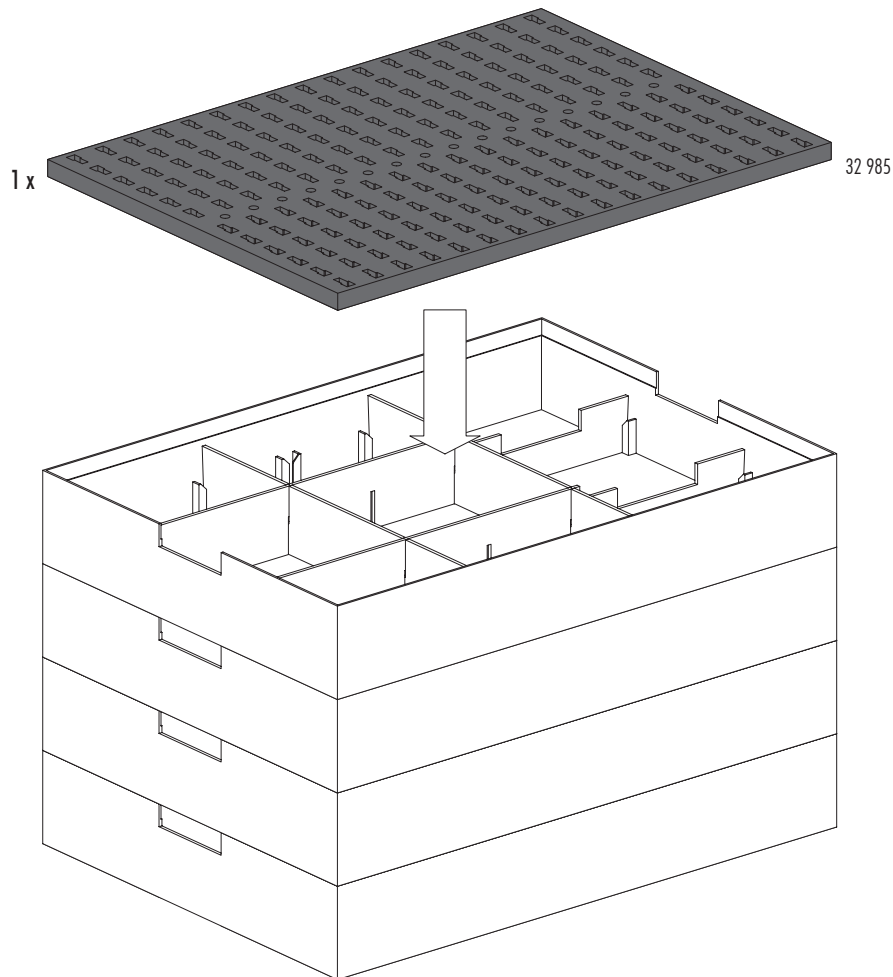

Hinweise zum Umweltschutz

Die elektrischen und elektronischen Bauteile dieses Baukastens (z. B. Motoren, Lampen, Sensoren) gehören nicht in den Hausmüll. Sie müssen am Ende ihrer Lebensdauer an einem Sammelpunkt für das Recycling von elektrischen und elektronischen Geräten abgegeben werden. Das Symbol auf dem Produkt, der Verpackung oder der Anleitung weist darauf hin.

Instructions for Environmental Protection

Do not put the electrical and electronic components of this construction kit such as motors, lights and sensors in the household waste. At the end of their service life, take them to a collection point for the recycling of electrical and electronic devices. The symbol on the product, packaging or the instructions shows this.

Remarques de protection de l'environnement

Les composants électriques et électroniques de ce coffret (par ex. moteurs, lampes, capteurs) ne doivent pas être jetés avec les ordures ménagères. Lorsqu'elles ne sont plus utilisables, il faut les remettre auprès d'un centre de collecte spécialisé dans le recyclage des appareils électriques et électroniques. Le symbole sur le produit, l'emballage ou la notice d'instructions le signale.

Bescherming van het milieu

De elektrische en elektronische onderdelen van deze module (bijv. motoren, lampen, sensoren) behoren niet bij het huisvuil. Aan het einde van hun levensduur moeten ze worden ingeleverd bij een verzamelplaats voor de recycling van elektrische en elektronische apparaten. Het symbool op het product, de verpakking of de gebruiksaanwijzing wijst je daar ook op.

Notas con respecto a la protección del medio ambiente

Los componentes eléctricos y electrónicos de esta unidad modular (p. ej. motores, lámparas, sensores) no han de tirarse a la basura casera. Al final de su vida útil tienen que ser entregados en un puesto colector para el reciclaje de aparatos eléctricos y electrónicos. El símbolo sobre el producto, el embalaje o las instrucciones lo señala.

Instruções para a proteção do meio ambiente

Os componentes elétricos e eletrônicos deste módulo (p.ex. motores, lâmpadas, sensores) não pertencem ao lixo doméstico. Eles devem ser entregues, no final da sua vida útil, num posto de coleta para a reciclagem de aparelhos elétricos e eletrônicos. O símbolo no produto, na embalagem ou no manual indica isto.

Indicazioni sulla tutela ambientale

I componenti elettrici ed elettronici di questa scatola di montaggio (ad es. motori, lampadine, sensori) non vanno smaltiti tra i rifiuti domestici. Alla fine della loro durata di utilizzo devono essere consegnati a un centro di raccolta adibito al riciclaggio di apparecchi elettrici ed elettronici. Ciò viene indicato dal simbolo che si trova sul prodotto, sull'imballo o sul manuale d'istruzioni.

Указания по охране окружающей среды

Электрические и электронные детали этого комплекта (датчики, электромоторы, лампочки и др.) нельзя выбрасывать с бытовым мусором. После того как они отслужат свой срок, их нужно сдать для переработки на сборный пункт электрических и электронных приборов. На это указывает знак на изделии, на упаковке или на инструкции.

有关环保的提示

不得将本组件中的电气和电子部件(如电机, 灯泡, 传感器)当作家庭垃圾扔掉。等它们的使用寿命结束后, 应将它们送抵电气和电子器材回收站。产品、包装或说明书上的标记也说明这一规定。



Sortiervorschlag Box 1 für Aufbewahrungssystem Art.-Nr. 94828

Storage suggestion box 1 for storage system Art No. 94828

Suggestion de classement Boîte 1 pour le système de stockage Art n° 94828

Sorteervoorstel box 1 voor bewaarsysteem art.-nr. 94828

Propuesta de clasificación Caja 1 para almacenamiento Art. Nº 94828

Proposta de divisão caixa 1 para sistema de conservação n.º de art. 94828

Proposta di sistemazione Box 1 per il sistema di conservazione, cod. prod. 94828

Рекомендации по сортировке: Бокс 1 для хранения арт. № 94828

用于产品号为94828的保存系统的1号盒分类建议

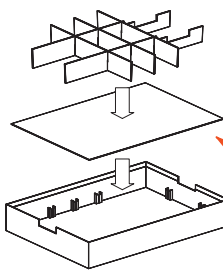

Zum Ausschneiden und Einlegen
For cutting out and inserting
A découper et à poser
Uitknippen en aanbrengen
Para cortar y montar
Para cortar e colocar
Da tagliare e inserire
Вырезать и вложить
用于剪下和放入

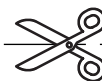

Sortiervorschlag Box 2 für Aufbewahrungssystem Art.-Nr. 94828

Storage suggestion box 2 for storage system Art No. 94828

Suggestion de classement Boîte 2 pour le système de stockage Art n° 94828

Sorteervoorstel box 2 voor bewaarsysteem art.-nr. 94828

Propuesta de clasificación Caja 2 para almacenamiento Art. N° 94828

Proposta de divisão caixa 2 para sistema de conservação n.º de art. 94828

Proposta di sistemazione Box 2 per il sistema di conservazione, cod. prod. 94828

Рекомендации по сортировке: Бокс 2 для хранения арт. № 94828

用于产品号为94828的保存系统的2号盒分类建议

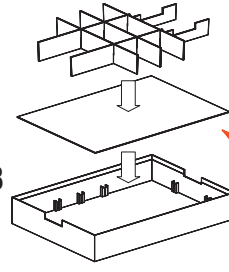

Zum Ausschneiden und Einlegen
For cutting out and inserting
A découper et à poser
Uitknippen en aanbrengen
Para cortar y montar
Para cortar e colocar
Da tagliare e inserire
Вырезать и вложить
用于剪下和放入

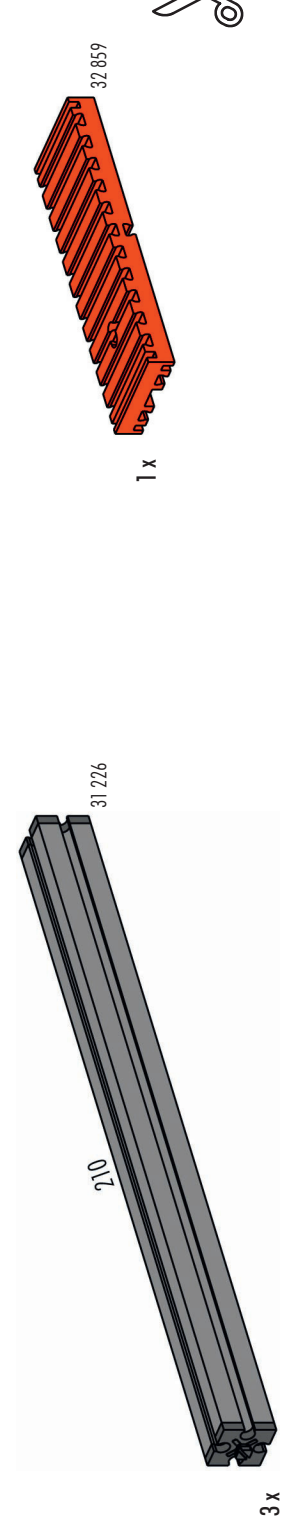
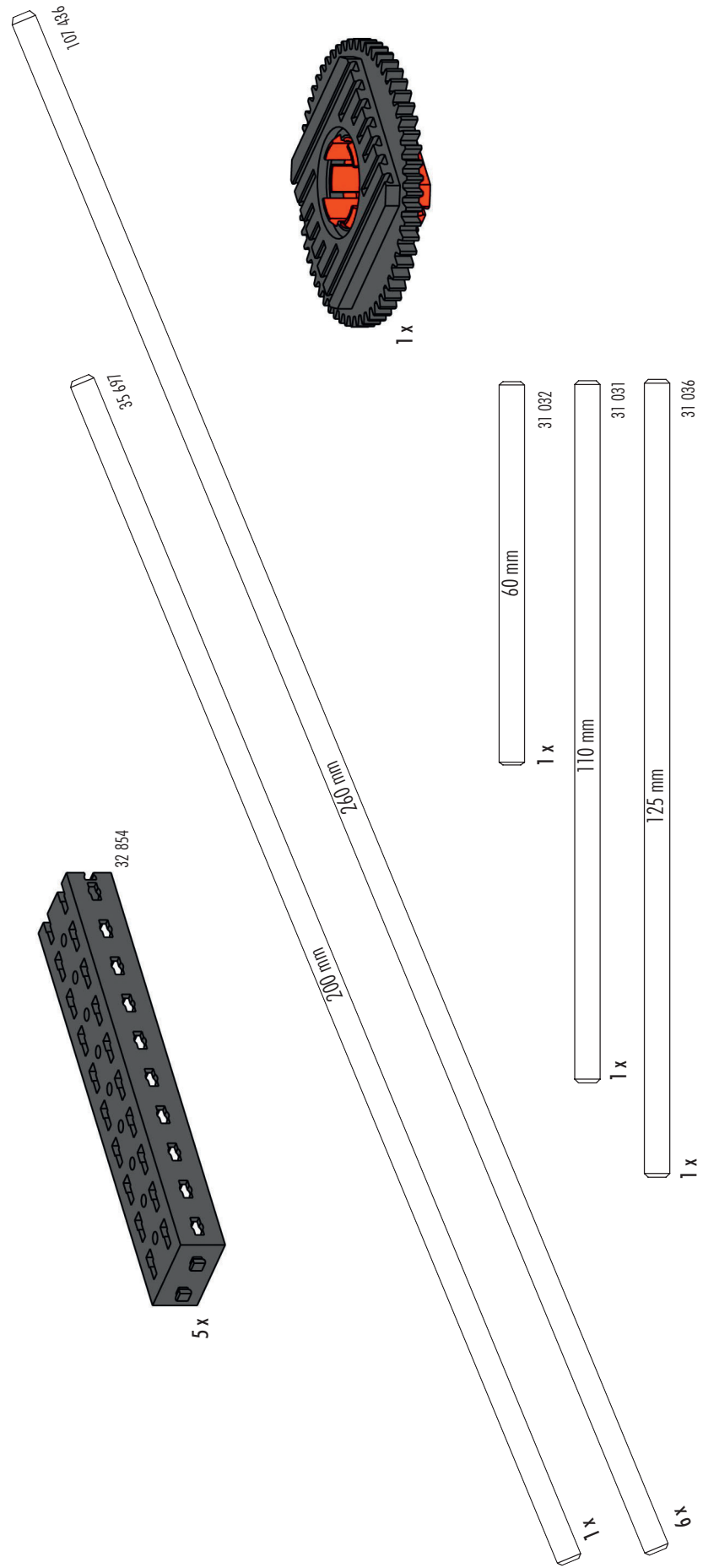

Sortiervorschlag Box 3 für Aufbewahrungssystem Art.-Nr. 94828

Storage suggestion box 3 for storage system Art No. 94828

Suggestion de classement Boîte 3 pour le système de stockage Art n° 94828

Sorteervoorstel box 3 voor bewaarsysteem art.-nr. 94828

Propuesta de clasificación Caja 3 para almacenamiento Art. N° 94828

Proposta de divisão caixa 3 para sistema de conservação n.º de art. 94828

Proposta di sistemazione Box 3 per il sistema di conservazione, cod. prod. 94828

Рекомендации по сортировке: Бокс 3 для хранения арт. № 94828

用于产品号为94828的保存系统的3号盒分类建议

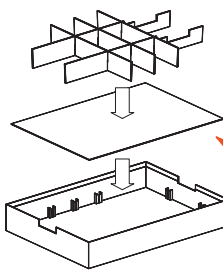

Zum Ausschneiden und Einlegen
For cutting out and inserting
A découper et à poser
Uitknippen en aanbrengen
Para cortar y montar
Para cortar e colocar
Da tagliare e inserire
Вырезать и вложить
用于剪下和放入

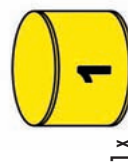
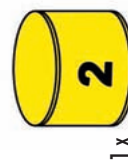
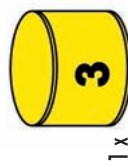
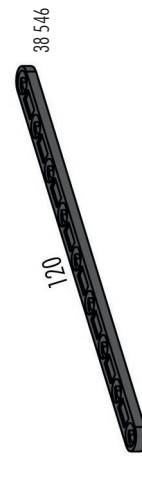
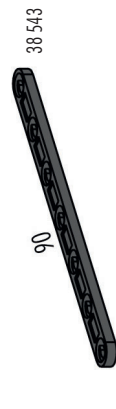
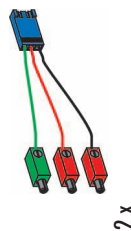
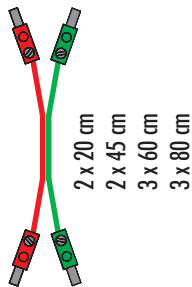

Sortiervorschlag Box 4 für Aufbewahrungssystem Art.-Nr. 94828

Storage suggestion box 4 for storage system Art No. 94828

Suggestion de classement Boîte 4 pour le système de stockage Art n° 94828

Sorteervoorstel box 4 voor bewaarsysteem art.-nr. 94828

Propuesta de clasificación Caja 4 para almacenamiento Art. N° 94828

Proposta de divisão caixa 4 para sistema de conservação n.º de art. 94828



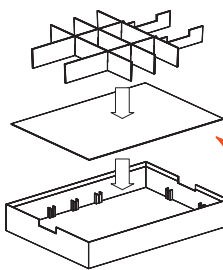

Proposta di sistemazione Box 4 per il sistema di conservazione, cod. prod. 94828

Рекомендации по сортировке: Бокс 4 для хранения арт. № 94828

用于产品号为94828的保存系统的4号盒分类建议

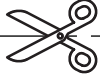
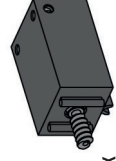

Zum Ausschneiden und Einlegen
For cutting out and inserting
À découper et à poser
Uitknippen en aanbrengen
Para cortar y montar
Para cortar e colocar
Da tagliare e inserire
Вырезать и вложить
用于剪下和放入

  2 x  13 x  2 x  2 x  6 x  2 x  1 x 	 3 x  2 x	  2 x  1 x  1 x  2 x
 2 x  12 x  6 x	 12 x  4 x  15 x  45 x  15 x	 4 x  2 x  1 x
 74 x	 3 x  6 x  4 x <div style="text-align: center;">30 mm</div>	 2 x  8 x  4  12 x
 18 x  8 x  25 x	 18 x  8 x	 25 x

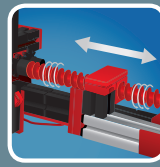

fischertechnik 

COMPUTING

fischertechnik GmbH
Weinhalde 14-18
72178 Waldachtal
Germany

Phone: +49 74 43/12-43 69
Fax: +49 74 43/12-45 91

info@fischertechnik.de
www.fischertechnik.de

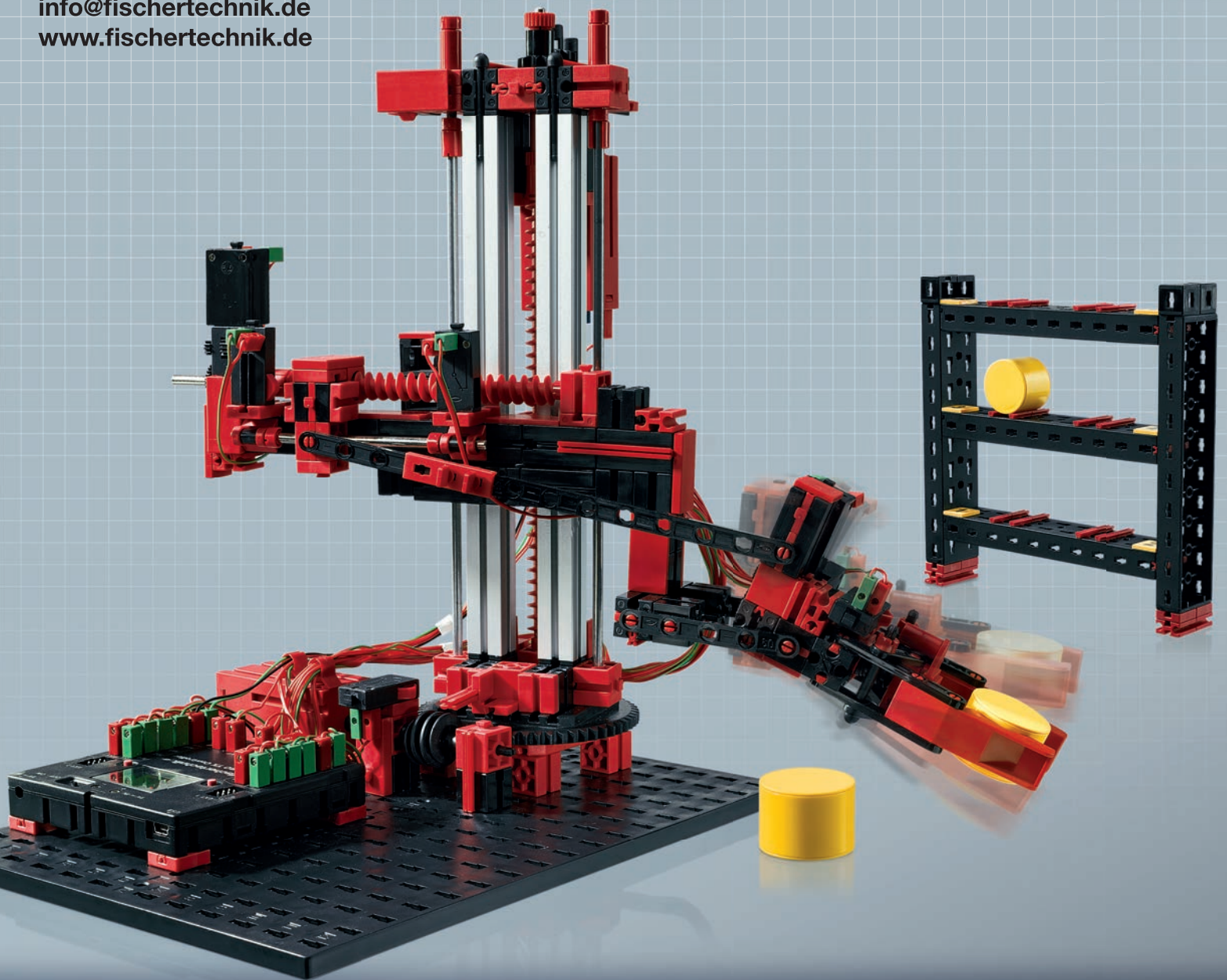

143387 - Printed in Germany - Technische Änderungen vorbehalten - Subject to technical modifications

ROBO TX Automation Robots

4 MODELS